

		Power Meter									
											
		PM9/PM9P/PM9C	PM500	PM700	PM700P	PM710	PM750	PM810	PM820	PM850	PM870
IM code		510	611 to 641	521	521	521	541	641	772	772	774
General selection criteria											
Installation		On DIN rail	Flush mount	Flush mount				Flush mount			
Use on LV distribution systems		■	■	■	■	■	■	■	■	■	■
Use on LV and HV distribution systems		-	■	■	■	■	■	■	■	■	■
Current / voltage accuracy		0.5 %	0.5 %	0.5 %	0.5 %	0.5 %	0.5 %	0.1 %	0.1 %	0.1 %	0.1 %
Power / active energy accuracy		2 %	1 %	1 %	1 %	1 %	0.5 %	0.5 %	0.5 %	0.5 %	0.5 %
Instantaneous rms values											
Current	■ Phases	■	■	■	■	■	■	■	■	■	■
	■ Neutral	■	■	■	■	■	■	■	■	■	■
	■ Extended measurement range	-	-	-	-	-	-	-	-	-	-
Voltage		■	■	■	■	■	■	■	■	■	■
Frequency		■	■	■	■	■	■	■	■	■	■
Total power	■ Active	■	■	■	■	■	■ ⁽³⁾	■	■	■	■
	■ Reactive	■	■	■	■	■	■ ⁽³⁾	■	■	■	■
	■ Apparent	■	■	■	■	■	■	■	■	■	■
Power per phase	■ Active	■	■	■	■	■	■	■	■	■	■
	■ Reactive	■	■	■	■	■	■	■	■	■	■
	■ Apparent	-	■	■	■	■	■	■	■	■	■
Power factor	■ Total	■	■	absolute	absolute	absolute	signed	■	■	■	■
	■ Per phase	-	■	-	-	-	-	■	■	■	■
Energy values											
Active energy		■	■	■	■	■	■ ⁽³⁾	In/Out	In/Out	In/Out	In/Out
Reactive energy		■	■	■	■	■	■ ⁽³⁾	In/Out	In/Out	In/Out	In/Out
Apparent energy		-	■	■	■	■	■	■	■	■	■
User-set accumulation mode		-	-	-	-	-	-	■	■	■	■
Demand values											
Current	Present and maximum values	-	■	■	■	■	■	■	■	■	■
Total active power	Present and maximum values	■	■	■	■	■	■	■	■	■	■
Total reactive power	Present and maximum values	-	■	■	■	■	■	■	■	■	■
Total apparent power	Present and maximum values	-	■	■	■	■	■	■	■	■	■
Total predicted demand	kW, kVAR, kVA	-	-	-	-	-	-	■	■	■	■
Synchronisation of calculation window		-	Option	-	-	-	■	■	■	■	■
User-set calculation mode		-	-	■	■	■	■	■	■	■	■
Other measurements											
Hour counter		■	■	■	■	■	■	■	■	■	■

(1) Measurement sensors included.

(2) Not available with Digipact communication card.

(3) Active and Reactive Power and Energy are signed and net consumption values.

		Power Meter									
											
		PM9/PM9P/PM9C	PM500	PM700	PM700P	PM710	PM750	PM810	PM820	PM850	PM870
Power quality measurements											
Interharmonics		-	-	-	-	-	-	-	-	-	-
Total harmonic distortion	■ Voltage	-	■	■	■	■	■	■	■	■	■
	■ Current	-	■	■	■	■	■	■	■	■	■
Individual harmonic content (current and voltage)		-	-	-	-	-	-	31 ⁽¹⁾	31	63	63
Waveform capture		-	-	-	-	-	-	-	-	■	■ ⁽²⁾
Detection of voltage sags and swells		-	-	-	-	-	-	-	-	-	■
Programmable (logic and mathematical functions)		-	-	-	-	-	-	-	-	-	-
Detection and capture of transients (< 1 µs)		-	-	-	-	-	-	-	-	-	-
Flicker		-	-	-	-	-	-	-	-	-	-
EN 50160 compliance checking		-	-	-	-	-	-	-	-	■ ⁽³⁾	■ ⁽³⁾
True rms measurement	Maximum harmonic number	15	31	15	15	15	15	63	63	63	63
	Points per cycle	-	-	32	32	32	32	128	128	128	128
Data recording											
Min/max of instantaneous values		-	Option	■	■	■	■	■	■	■	■
Data logging		-	-	-	-	-	-	2 ⁽¹⁾	2	4	4
Event logging		-	-	-	-	-	-	-	■	■	■
Trend curves		-	-	-	-	-	-	-	-	■	■
Alarms		-	Option	-	-	-	■	■	■	■	■
Alarm notification via email		-	-	-	-	-	-	-	-	-	-
Sequence of Events Recording		-	-	-	-	-	-	-	-	-	-
Date and time stamping		-	-	-	-	-	-	■	■	■	■
GPS time synchronisation		-	-	-	-	-	-	-	-	-	-
Storage capacity		-	-	-	-	-	-	80 kB ⁽¹⁾	80 kB	800 kB	800 kB
Display, sensors, input/outputs											
Front-panel display		■	■	■	■	■	■	■	■	■	■
Built-in current and voltage sensors		-	-	-	-	-	-	-	-	-	-
Digital or analogue inputs (max. number)		-	3	-	-	-	2	13	13	13	13
Pulse outputs		1 (PM9P)	Option	-	2	-	1	1	1	1	1
Digital or analogue outputs (max. number including pulse outputs)		1 (PM9P)	5	-	2	-	1	9	9	9	9
Input metering capability (number of channels)		-	-	-	-	-	-	5	5	5	5
Direct voltage connections without external VT		450 V	480 V	480 V	480 V	480 V	480 V	600 V	600 V	600 V	600 V
Power supply											
AC/DC version	AC	230 V	110 to 400 V	100 to 415 V				100 to 415 V			
	DC	-	120 to 350 V	125 to 250 V				125 to 250 V			
DC version		24 to 48 V	24 to 48 V	With CPM24 or CPM48 accessory (option)							
Communication											
RS 485 port		■ (PM9C)	Option	-	-	■	■	2-wire (on board) 4-wire (with remote display)			
Infra-red port		-	-	-	-	-	-	-	-	-	-
RS 232 port		-	-	-	-	-	-	With remote display			
Modbus (M), Digipact (D) protocol		M	M	-	-	M	M	M	M	M	M
Ethernet port (Modbus/TCP/IP protocol)		-	-	-	-	-	-	-	-	-	-
HTML Web-page server		-	-	-	-	-	-	-	-	-	-
Ethernet gateway for other products on an RS 485 link		-	-	-	-	-	-	-	-	-	-

(1) With PM810LOG.

(2) Configurable.

(3) Except for interharmonics, signalling voltage, flicker and transients.

Circuit Monitor



CM3250	CM3350	CM4250	CM4000T
-	-	■	-
■	■	■	■
■	■	■	■
■	■	■	■
■	■	■	■
-	■	■	■
-	-	■	■
-	-	-	■
-	-	-	■
■ (8)	■ (8)	■ (8)	■ (9)
63	63	255	255
128	128	512	100 000 at 50 Hz 83 333 at 60 Hz
■	■	■	■
14	14	14	14
■	■	■	■
■	■	■	■
■	■	■	■
Option	Option	Option	Option
■	■	■	■
■	■	■	■
Option	Option	Option	Option
8 MB	8 MB	Up to 32 MB	Up to 32 MB
Option	Option	Option	Option
-	-	-	-
4	4	16 (6)	16 (6)
1	1	1	1
5	5	17 (6)	17 (6)
10	10	10	10
600 V	600 V	690 V	600 V
100 to 275 V (±10 %)		100 to 275 V (±10 %)	
125 to 250 V (±20 %)		125 to 250 V (±20 %)	
With CPM24 or CPM48 accessory (option)			
■	■	■	■
Option	Option	Option	Option
-	-	■	■
M	M	M	M
Option	Option	Option	Option
Option	Option	Option	Option
Option	Option	Option	Option

Micrologic control units for low-voltage circuit breakers



A	P	H
-	-	-
-	-	■
-	-	■
-	-	■ (4)
-	-	■ (4)
-	-	-
-	-	-
-	-	-
-	-	-
-	-	-
-	-	-
-	-	-
12	31	31
24	64	64
■ (5)	■ (4)	■ (4)
-	-	-
-	■ (4)	■ (4)
-	-	-
-	■	■
-	-	-
-	-	-
-	■	■
-	-	-
-	-	-
6	6	6
-	-	-
690 V	690 V	690 V
(7)	(7)	(7)
(7)	(7)	(7)
(7)	(7)	(7)
Option	Option	Option
-	-	-
-	-	-
M, D	M, D	M, D
-	-	-
-	-	-
-	-	-

Separate catalogue

(4) Not available with Digipact communication card.
 (5) Maximum only.
 (6) The total number of inputs and outputs may not exceed 25.
 (7) Self-powered.
 (8) Except for interharmonics, signalling voltage, flicker and transients.
 (9) Except for interharmonics and signalling voltage.



EM463

PB102160-51



PB102161-51



The PowerLogic Power Meter Series 700 offers all the measurement capabilities required to monitor an electrical installation in a single 96 x 96 mm unit extending only 50 mm behind the mounting surface.

With its large display, you can monitor all three phases and neutral at the same time. The anti-glare display features large 11 mm high characters and powerful backlighting for easy reading even in extreme lighting conditions and viewing angles.

The Power Meter Series 700 is available in four versions:

- PM700, basic metering with THD and min/max readings
- PM700P, same functions as the PM700, plus two solid-state pulse outputs for energy metering
- PM710, same functions as the PM700, plus one RS 485 port for Modbus communication
- PM750, same functions as the PM710, plus two digital inputs, one digital output, alarms and signed power factor.

Applications

- Panel instrumentation.
- Sub-billing and cost allocation.
- Remote monitoring of an electrical installation.
- Harmonic monitoring (THD).
- Alarming with under/over conditions and I/O status (PM750)

Characteristics

Requires only 50 mm behind mounting surface

The Power Meter Series 700 can be mounted on switchboard doors to maximise free space for electrical devices.

Large back lit display with integrated bar charts

Displays 4 measurements at a time for fast readings.

Intuitive use

Easy navigation using context-sensitive menus.

Power and current demand, THD and min/max reading in basic version

A high-performance solution for trouble-free monitoring of your electrical installation.

Active energy class IEC 62053-22 class 0.5S (PM750) and IEC 62053-21 class 1 (PM700, PM700P, PM710)

Suitable for sub-billing and cost-allocation applications.

Innovative Power Meter

RS 485 communications, alarming and digital I/O in a single Power Meter (PM750).

Part numbers

Power Meter	
Merlin Gerin brand	
PM700 Power Meter	PM700MG
PM700P Power Meter	PM700PMG
PM710 Power Meter	PM710MG
PM750 Power Meter	PM750MG
Square D brand	
PM700 Power Meter	PM700
PM700P Power Meter	PM700P
PM710 Power Meter	PM710
PM750 Power Meter	PM750

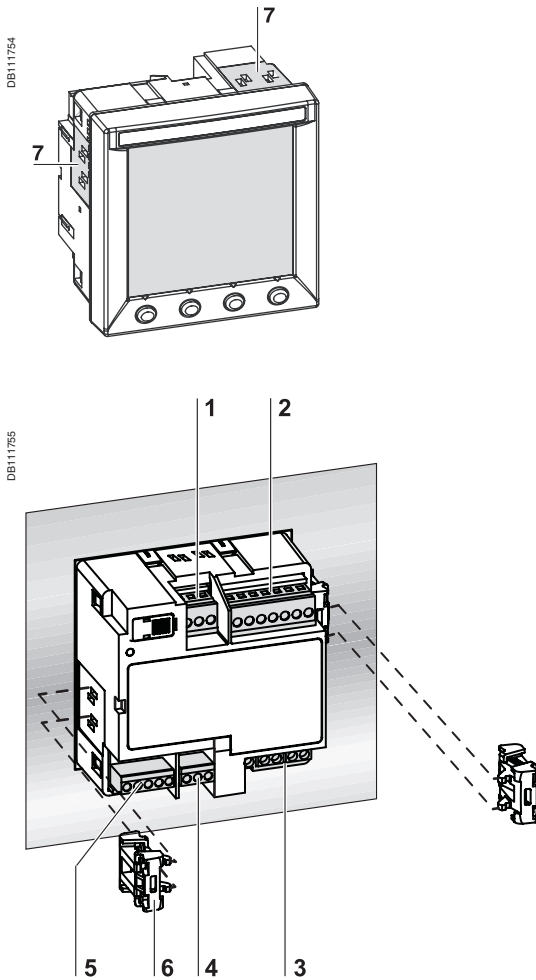

Power Meter 750.

- 1 Control power.
- 2 Voltage inputs.
- 3 Current inputs.
- 4 RS 485 port.
- 5 Digital input/output.
- 6 Mounting clips.
- 7 Mounting slot.

Selection guide		PM700	PM700P	PM710	PM750
General					
Use on LV and HV systems		■	■	■	■
Current and voltage accuracy		0.5 %	0.5 %	0.5 %	0.5 %
Active energy accuracy		1.0 %	1.0 %	1.0 %	0.5 %
Reactive energy accuracy		2 %	2 %	2 %	2 %
Instantaneous rms values					
Current	Phases and neutral	■	■	■	■
Voltage	Ph-Ph and Ph-N	■	■	■	■
Frequency		■	■	■	■
Active, reactive, apparent power	Total and per phase	■	■	■	signed ⁽¹⁾
Power factor	Total	absolute	absolute	absolute	signed
Energy values					
Active, reactive, apparent energy		■	■	■	signed ⁽¹⁾
Demand values					
Current	Present and max.	■	■	■	■
Active, reactive, apparent power	Present and max.	■	■	■	■
Setting of calculation mode	Block, sliding, input synchronisation mode	■	■	■	■
Other measurements					
Hour counter		■	■	■	■
Power quality measurements					
Harmonic distortion	Current and voltage	■	■	■	■
Data recording					
Min/max of instantaneous values		■	■	■	■
Alarms		-	-	-	■ ⁽²⁾
Display and I/O					
Backlit LCD display		■	■	■	■
Digital inputs		-	-	-	2 ⁽³⁾
Digital outputs		-	2 ⁽⁴⁾	-	1 ⁽⁵⁾
Communication					
RS 485 port		-	-	■	■
Modbus protocol		-	-	■	■

⁽¹⁾ kW, kVAR, kWh and kVARh are signed net consumption values.
⁽²⁾ 15 user-configurable under and over conditions and in combination with digital inputs or outputs status.
⁽³⁾ 2 operation modes are available: normal or input demand synchronisation.
⁽⁴⁾ kWh and kVARh pulse output mode only.
⁽⁵⁾ 3 operation modes are available: external, alarm or kWh pulse output.



Rear view of Power Meter Series 700 (PM750).

Electrical characteristics

Type of measurement	True rms up to the 15th harmonic on three-phase (3P, 3P + N) two-phase and single-phase AC systems 32 samples per cycle		
Measurement accuracy	Current	0.5 % from 1 A to 6 A	
	Voltage	0.5 % from 50 V to 277 V	
	Power Factor	0.5 % from 1 A to 6 A	
	Power	1 %	
	Frequency	±0.02 % from 45 to 65 Hz	
Active Energy	Class 1 as defined by IEC 62053-21 ⁽¹⁾		
	Class 0.5S as defined by IEC 62053-22 ⁽²⁾		
Reactive Energy	Class 2 as defined by IEC 62053-23		
Data update rate	1 s		
Input-voltage characteristics	Measured voltage	10 to 480 V AC (direct Ph-Ph) 10 to 277 V AC (direct Ph-N) up to 1.6 MV AC (with external VT) the lower limit of the measurement range depends on the PT ratio	
	Metering over-range	1.2 Un	
	Impedance	2 MΩ (Ph-Ph) / 1 MΩ (Ph-N)	
	Frequency range	45 to 65 Hz	
Input-current characteristics	CT ratings	Primary	Adjustable from 5 A to 32767 A
		Secondary	1 A or 5 A
	Measurement input range	5 mA to 6 A	
	Permissible overload	15 A continuous 50 A for 10 seconds per hour 120 A for 1 second per hour	
Power supply	AC	100 to 415 ±10 % V AC, 5 VA	
	DC	125 to 250 ±20 % V DC, 3 W	
	Ride-through time	100 ms at 120 V AC	
Input	Digital inputs (PM750)	12 to 36 V DC, 24 V DC nominal, 12 kΩ impedance, 2.5 kV rms isolation, max. frequency 25 Hz, response time 10 ms	
Output	Pulse outputs (PM700P)	3 to 240 V DC or 6 to 240 V AC, 100 mA at 25 °C, derate 0.56 mA per °C above 25 °C, 2.41 kV rms isolation, 30 Ω on-resistance at 100 mA	
	Digital or pulse outputs (PM750)	8 to 36 V DC, 24 V DC nominal at 25 °C, 3.0 kV rms isolation, 28 Ω on-resistance at 100 mA	

Mechanical characteristics

Weight	0.37 kg
IP degree of protection (IEC 60529)	IP52 front display, IP30 meter body
Dimensions	96 x 96 x 69 mm (meter with display)
	96 x 96 x 50 mm (behind mounting surface)

Environmental conditions

Operating temperature	Meter	-5 °C to +60 °C
	Display	-10 °C to +50 °C
Storage temp.	Meter + display	-40 °C to +85 °C
Humidity rating	5 to 95 % RH at 50 °C (non-condensing)	
Pollution degree	2	
Metering category	III, for distribution systems up to 277/480 V AC	
Dielectric withstand	As per EN 61010, UL508 - Double insulated front panel display	
Altitude	3000 m max.	

Electromagnetic compatibility

Electrostatic discharge	Level III (IEC 61000-4-2)
Immunity to radiated fields	Level III (IEC 61000-4-3)
Immunity to fast transients	Level III (IEC 61000-4-4)
Immunity to impulse waves	Level III (IEC 61000-4-5)
Conducted immunity	Level III (IEC 61000-4-6)
Immunity to magnetic fields	Level III (IEC 61000-4-8)
Immunity to voltage dips	Level III (IEC 61000-4-11)
Conducted and radiated emissions	CE commercial environment/FCC part 15 class B EN 55011
Harmonics emissions	IEC 61000-3-2
Flicker emissions	IEC 61000-3-3

⁽¹⁾ PM700, PM700P, PM710.

⁽²⁾ PM750.

Safety

Europe	C \in , as per IEC 61010-1 ⁽¹⁾
U.S. and Canada	UL508

Communication

RS 485 port (PM710 and PM750)	2-wire, up to 19200 bauds, Modbus RTU (double insulation)
-------------------------------	---

Display characteristics

Dimensions 73 x 69 mm	Back-lit green LCD (6 lines total, 4 concurrent values)
-----------------------	--

Firmware characteristics

Min./max.	Worst min. and max. with phase indication for voltages, currents and THD. Min. and max. values for power factor, power (P, Q, S) and frequency
-----------	---

⁽¹⁾ Protected throughout by double insulation .

Dimensions

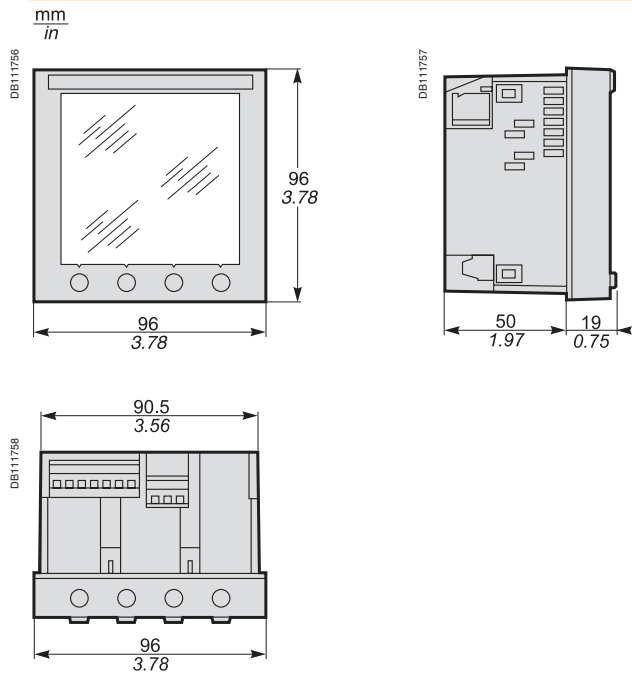

Front-panel mounting

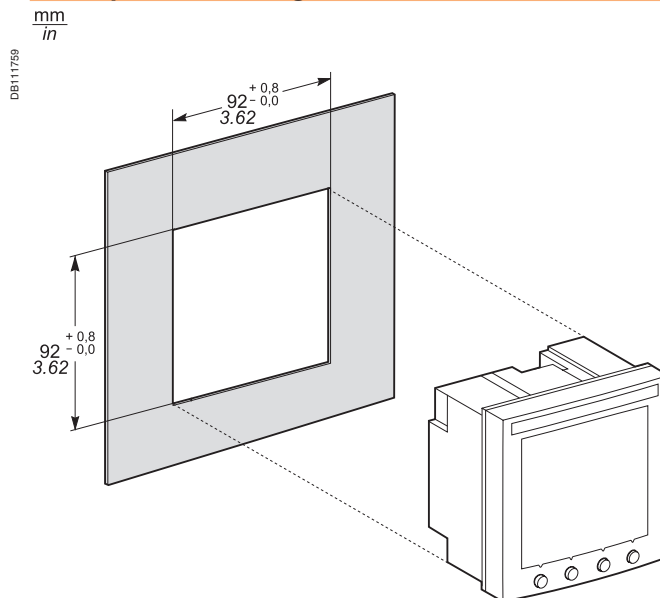

4-wire connection with 3 CTs and no PT

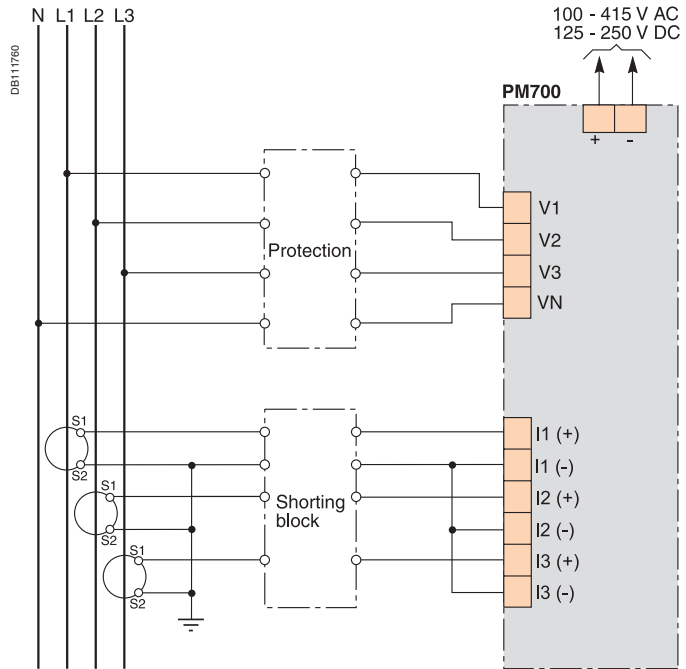

Connection example.

3-wire connection with 2 CTs and 2 PTs

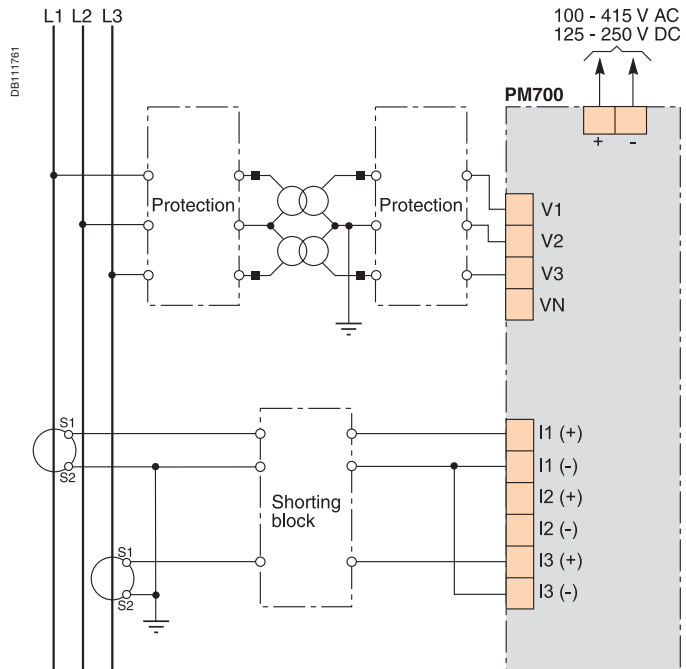

Connection example.

Note: other types of connection are possible. See product documentation.

PM700P pulse output capabilities

There are two solid-state KY outputs. One is dedicated to kWh and the other to kVARh.

Pulse Output: KY is a solid state pulse output rated for 240 V AC/DC max.

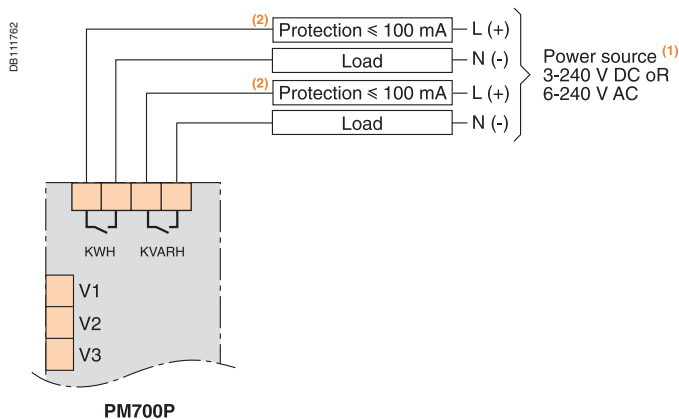

(1) The power source should not be a safety extra low voltage (SELV) circuit. Pulse outputs are not SELV rated.

(2) Overcurrent protective device (not supplied). This device must be rated for short circuits at the connection point.

PM750 input/output capabilities

The PM750 has two digital inputs and one digital output. The digital inputs have two operating modes: Normal and Demand Sync.

The digital output has three operating modes: External Control (default), Alarm and kWh Pulse mode. When configured in Alarm mode, the digital output can be controlled by the meter in response to an alarm condition.

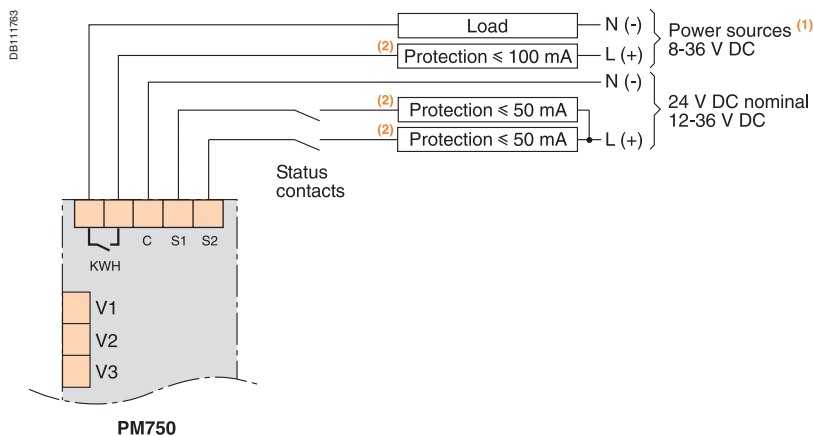

(1) The power source should not be a safety extra low voltage (SELV) circuit. Pulse outputs are not SELV rated.

(2) Overcurrent protective device (not supplied). This device must be rated for short circuits at the connection point.

Communications (PM710 and PM750)
2-wire daisy-chain connection of devices (RS 485)

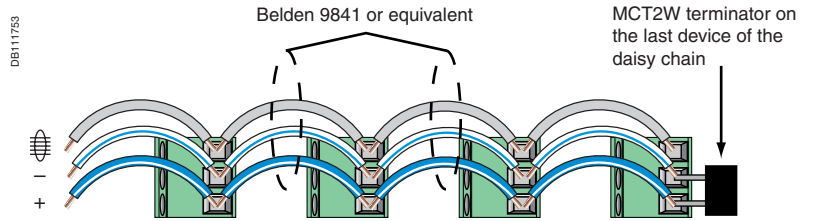

Belden 9841 wire colors: blue with white stripe (+), white with blue stripe (-), and silver (shield).