

Smart sensor (With ultra high-speed CCD cameras)

ZFV Series

Easy Vision, Teach&Go-In color and monochrome

Smart sensor with advanced features of image sensor at implementation cost of optical sensor

- Integration of sensor and illumination allows for easy installation
- Intuitive icon based operation using LCD display
- Ultra-high response supports fast lines



OMRON

NEW

Vision sensor with built-in LCD monitor

"Smart Sensor" ZFX-C



This document provides information mainly for selecting suitable models. Please read the User's Manual (Z251-E1-01) carefully for information that the user must understand and accept before purchase, including information on warranty, limitations of liability, and precautions.

OMRON Corporation Industrial Automation Company

Sensing Devices Division H.Q.
Application Sensors Division
Shiokoji Horikawa, Shimogyo-ku,
Kyoto, 600-8530 Japan
Tel: (81)75-344-7068/Fax: (81)75-344-7107

Regional Headquarters

OMRON EUROPE B.V.
Sensor Business Unit,
Carl-Benz-Str. 4 D-71154 Nufringen,
Germany
Tel: (49)7032-811-0/Fax: (49)7032-811-199

OMRON ELECTRONICS LLC
1 East Commerce Drive, Schaumburg,
IL 60173 U.S.A.
Tel: (1)847-843-7900/Fax: (1)847-843-8568

OMRON ASIA PACIFIC PTE. LTD.
438A Alexandra Road,
#05-05/08, Alexandra Technopark,
119967 Singapore
Tel: (65)6835-3011/Fax: (65)6835-2711

OMRON (CHINA) CO., LTD.
Room 2211, Bank of China Tower,
200 Yin Cheng Road (M),
Shanghai, 200120 China
Tel: (86)21-5037-2222/Fax: (86)21-5037-2200

Authorized Distributor:

Note: Specifications subject to change without notice.

Cat. No. E381-E4-01
Printed in Japan
0307-5M (0307) (H)

"Essential Innovation for Future Generations"

realizing

Easy Vision Being Our Vision

The Omron's new ZFX-C Smart Vision Sensor is a total Image Processing system that includes everything from a camera with an integrated light source to an image-processing unit.

With Omron's newly developed proprietary measurement algorithm, the parameter can be set through only a few steps involving the operation of a touch-panel color monitor.

This "Smart" user interface provides simplicity of usage giving anyone all they can need to perform a complete image enhancement.

The new technology and style of the ZFX-C paves the way to a new era of vision sensors.

"Smart Recipe" with condensed know-how **World's first**

Capturing the image processing know-how Omron has accumulated over many years, the world's first "Smart Recipe" has radically reduced setting up time allowing for greater productivity.

One-touch automatic setting

The essential skills for image processing are now packaged into Omron's unique algorithm. The setting that traditionally required much fumbling is now made easy with the "select from auto listed options" using recipes. Lighting setup, the longtime problem for image processing, and the tricky parameter details involved in measurement setup, can now be done automatically with just the flip of a switch.



Smart Recipe

Smart Recipe is an Omron's invention of 3-step setting procedure. By adopting a new algorithm to encapsulate "human know-how", the auto setup for lighting and measurement now possible. Anyone can rapidly perform a high level of image processing.



Step1 Choose best lighting

Patent pending

The know-how and trial and error that have been indispensable and required much time and effort up to now in lighting setup is now an automated process. By just selecting the best one from the candidate images automatically captured by changing the lighting pattern with the auto-lighting, anyone can easily find the optimal lighting. User can now easily determine settings for shiny work with high degrees of reflection and black monochrome work with low degrees of reflection, something very tricky before. In addition, when a more detailed setup is needed, the customized setup can be used to incorporate know-how.

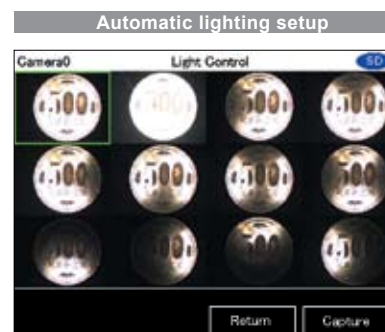

With automatic lighting setup, user can simply select the best image from thumbnail of candidate images.

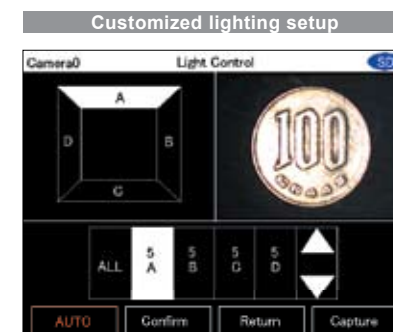

A more detailed set up is possible with the customized lighting setup while looking at the image.

Built-in lighting camera that enables an advanced automatic lighting



The Built-in lighting camera and improved controller brings about an even higher degree of automatic lighting. With this camera you can produce up to a maximum of 1296 patterns of reflective lighting making the chore of choosing lighting equipment unnecessary. The lighting setup can be managed as digital data so it is possible to store the optimal setup for each job, and it smoothly handles the changing of settings. It is also possible to fine-tune the customized setup can be added.

Step2 Choose measurement icon

The measurement method can be specified by just choosing the icon from out of a total of 9 measurement items for different types of inspection.

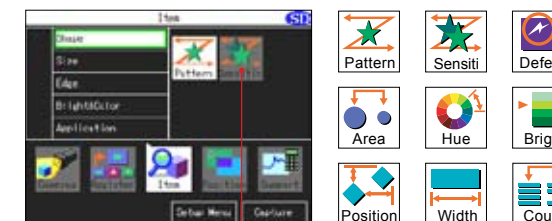

Basic operations merely through selection of on-screen icons
Intuitive operations

Step3 Draw region, press and go

Just specify the region of interest and press Auto key and the system will determine the most suitable parameters for the target image.

Now anyone can easily perform a complex and advanced parameter setting which used to require special knowledge and cumbersome steps.

Customized setting is also possible by fine tuning the parameters automatically set up. The time required to set up parameters can be significantly reduced.

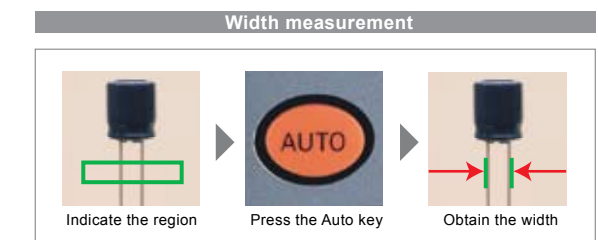

Appropriate filters and edge scan directions for width measurement can be automatically set by analyzing the target image.

Easily adjusts position

3-step position correction

Even when the position of work changes due to the conveyer condition, the excellent position correction function can come into play allowing adjustment using the work contours, two stage position correction and so on. With the auto setup, position difference can be easily adjusted to enable stable measurement.

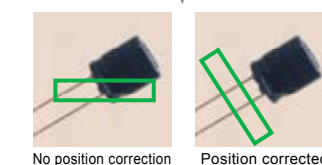
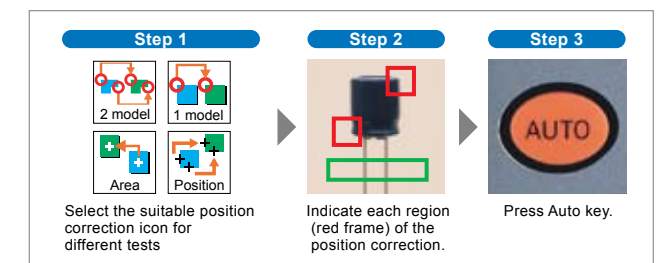

In response to the position difference, the measurement region is automatically adjusted.

Tailored Measurement Item

Including two shape measurement items, the system contains 5 categories and 9 types of Shape, Size, Edge, Bright and Hue, Application measurement items. It responds to the variety of inspection requirements in the manufacturing sites.



Shape measurement item

Pattern search

Fastest in the industry

The shape measurement is a fundamental algorithm for image processing. By adopting a new image processor, the pattern search achieves a balance in the three factors of speed, precision and stabilization, something that was an arduous task until now. It now supports a 360-degree revolving search and a sub-pixel processing of 1000 to 1 pixel units as well as a multi area searcher. The robust pattern search can respond to the multitude of inspects and measurements of any application.

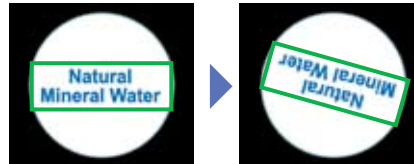

A further improvement is the balance achieved in revolving searches that occur in pattern matching for a revolving work. The most time-consuming 360-degree revolving search can be performed with an excellent accuracy.

Sensitive search

NEW

When it comes to the difficult processing of detecting small differences, the Omron's unique sensitive search matches work at a smallest detail and in doing so makes such detection all the more possible. It resists variations in position and density to capture even the smallest detail in the complex patterns.



It is possible to detect even the smallest differences in the work.

Application specific measurement item

Defect

It is used to detect smears, scratches, chipping and burrs on the work. Defects are displayed on the screen, which makes it ideal tool for visual inspection.



Almost indistinguishable scratches can be detected after enhancing contrast using the color filter.

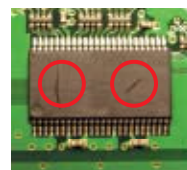

Counts the number of scratches

Size measurement item

Region

Detects the existence of work within a region and measures its size based on the area to perform various classification.



LED illumination is determined based on the area of extracted color.

Bright and Hue measurement item

Hue

NEW

The three factors in color, i.e. hue, saturation and brightness value, are measured and digitalized. And whilst an accurate differentiation of the color is performed, it is also possible to measure the color variety with the deviation measurement function (with color camera connected).

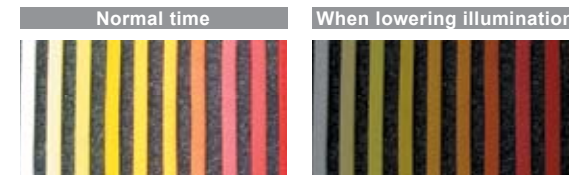

The individual threshold for the hue, saturation and brightness value parameters can be set up so that even if one of them is different, it can be detected accurately and intensely. On the other hand, by expanding the range for the brightness value and saturation, and so on, it is possible to stabilize the color detection in the hue without any interference from illumination alterations.

Bright

Measures the brightness within a region. It can be used for checking the presence of a component, etc., by generating average density and density deviation values.

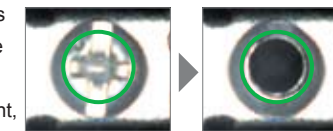

Based on the change in brightness, the presence of a screw (OK or NG) is determined.

Functions to support optimal measurements

Up to 32 regions

In one captured image, it is possible to measure a multiple up to 32 regions. When carrying out difficult inspection, it is possible to set-up a color filter and color extraction for each measurement item.

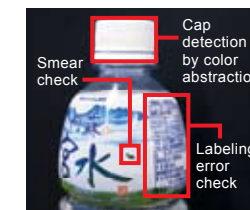

Measures three regions.

Screen registration function

It is possible to register the image used in the setup. When you use the live image during setup sometimes the set up is not correct due to position differences in the work. However, with the registered image saved in the SD memory card as a "master image for setup", it can be easily verified when abnormal measurements occur.

Edge measurement item

Position

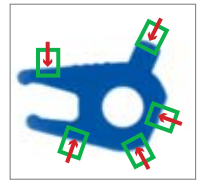

The existence or not and the position of the edge is measured. Oblique edges can now be measured even in complex conditions and even more accurate position measurements can be taken. The peak bottom measurement function that can accurately capture the edges is now supported.

Width

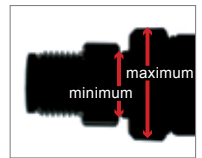

The width of the edge is measured. By using the edge partitioning method, it is possible to measure the maximum and minimum width.

Count



The number of edges inside the area is counted. Based on the number of edges on the pre-registered good model, it counts the edges in the area and determines the correctness.

Gray filtering setup using double screen

For each measurement item, it is possible to run 8 types of gray filtering such as expansion and contraction to enable stable measurements. Through the "setup while looking" option that makes it possible to check the preview, the optimal gray filtering can be selected.



Calculations function

It is possible to make arithmetical calculations for measurement values, and calculations involving general functions, trigonometry, geometrical functions and logical functions. It is possible to setup internal variables, and complex calculations can be carried out.

Visualized Controller

Smallest in class controller build in embedded LCD saves space and time.

Visualized setting and monitoring Smallest in class

Despite its small form factor, the enlarged screen significantly improves the visibility and the ease of operation. The method of operation can be selected from 3way - the touch pen, key pad or console.



Rich interface support

Automatically detects the connected camera and displays the appropriate menu. With rich selection of interface including parallel RS-232C/RS-422, USB 2.0, the extensibility is superior.

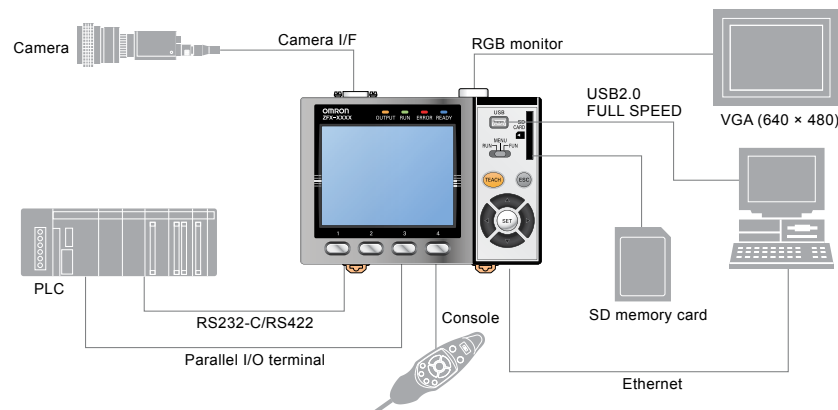

Intensive Camera Solutions

8 types of cameras that can be selected for different types of work to achieve optimal measurement.

Built-in lighting camera

Triple-speed camera (IP65)

Line up of 6 types of built-in lighting cameras that do not need lighting selection or setup. The color camera can respond to a wide range of work with a 5-150mm field of view. Through image compression and partial capturing, it can support a high-speed line.

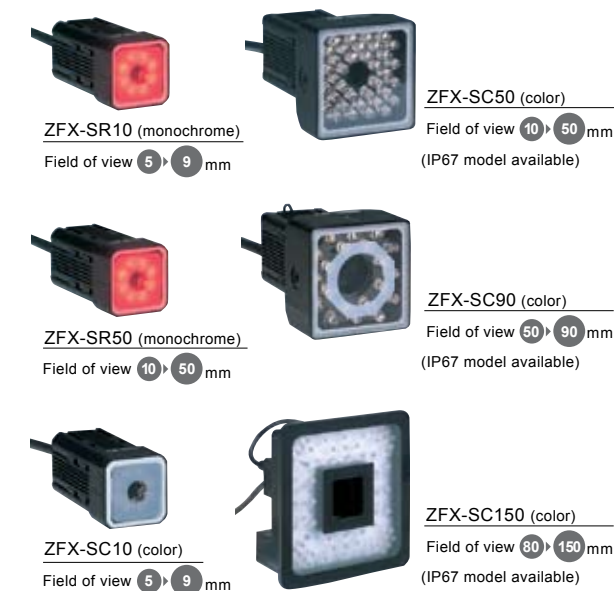

C-mount camera unit NEW

Triple-speed camera

This product line includes C-mount camera that can select the lens to match the field. It can be used in combination with optional lighting such as transmitted lighting, low angle lighting and bar lighting, etc. to support different inspection types.



Innovative triple-speed camera Fastest in the industry

Performs fast transfer of 11.1ms that are 3 times faster than standard cameras and 1.5 times faster than high-speed cameras while maintaining a resolution of the whole screen. In addition, a super speed, minimum 3.2ms transfer is possible with image compressions and partial capturing.

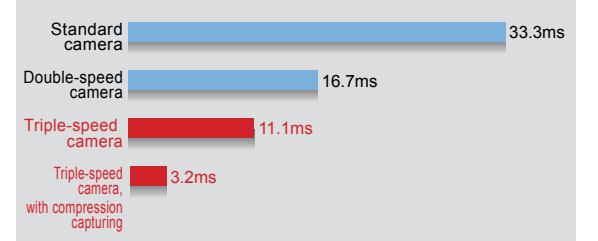

Excellent ease of use

Flexible installation

Flexible installation supported for different mounting site conditions. It can be mounted on DIN rail as well as on the control panel surface. (Optional panel mount adapter available.)

Hybrid interface

A new interface that supports both parallel I/O and terminal platform to dramatically improve the ease of wiring.



Advanced Color Engine

The ZFX-C's advanced auto-color processing ability makes stable and accurate measurements a reality, even for usually difficult to detect contrast and low lighting work.



Automatic color filter

Industry's first

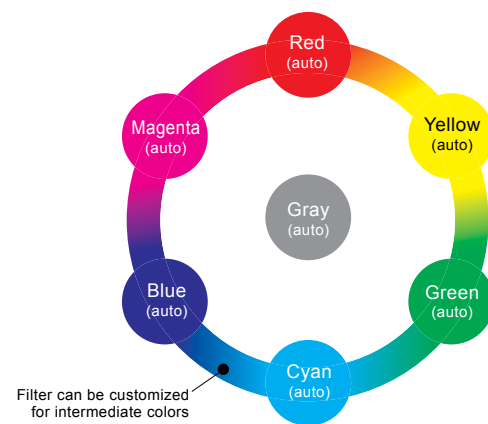

Even for images clearly distinguishable in color, when converted to monochrome the contrast tends to become low. Color filter analyzer automatically selects the optimal color filter (auto color filter) based on the image analysis result to adjust the contrast, to allow for stable image measurement. Any intermediate color can be arranged for the color filter using custom settings.

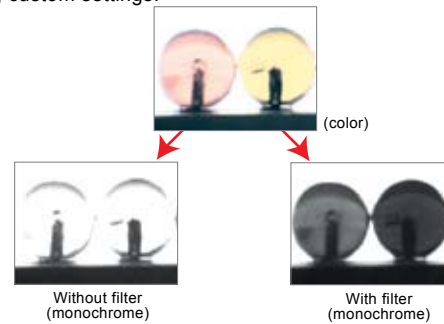

Choose desired color

NEW

Simply select from the list of colors

It is now possible to run an automatic pickup of color, something that used to be a complex procedure, using simply the Auto key. The advanced color engine automatically detects the color distribution in the selected range and automatically lists up to 4 optional color pickup in the order of color area. After that, user can simply select the desired color to be pickup.

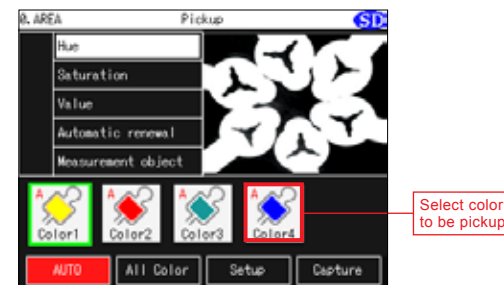

Specify the pickup area and press the Auto key to display 4 optional colors for pickup.

Fine-tuning by using dual-screen

The auto color pickup can fine-tune each of the hue, saturation and brightness value. Using double screens, the source image and the color pickup image can be compared and adjusted. This enables easy and stable pickup of colors with low illumination (traditionally difficult to pickup) and colors with large variation. The efficiency of operation is greatly increased.

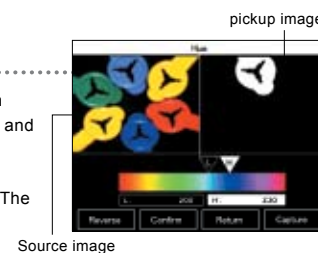

Versatile Support Tool

The concept behind Smart Recipe that eradicates the pain of image processing has been leveraged in the system ramp-up and deployment.

Image storing and re-measurement

Stores up to 100 files of image data in the main memory without slowing measurement speed. Images data can be re-measured so even with a high-speed line, for example, the results of the measurements can be checked at leisure afterwards.

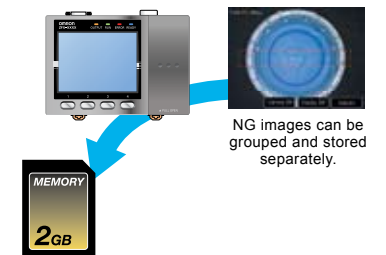

On-site fine adjustment

NEW

On site variety adjustment of work is essential. Without returning to the menu mode, the measurement region, color contrast setup and so on can be tuned in adjust mode, using double screen to compare with the original image. The measurement results of the stored images can also be displayed so the unnecessary rejects can be efficiently reduced.

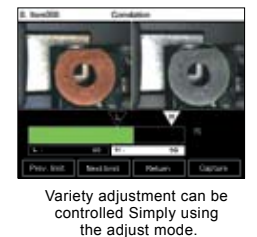

Variety adjustment can be controlled simply using the adjust mode.

Visualized monitoring and analysis

NEW

Through a list/individual view of measurement results, and a logging monitor display, user can easily understand the measurement situation. The results display can be chosen from 9 patterns including individual results view (upper left, upper middle), lists of results/region view (lower left, lower middle), list of results/All results view (upper right), and data list view (bottom right). The results can be reviewed in detail which is useful for statistical analysis.

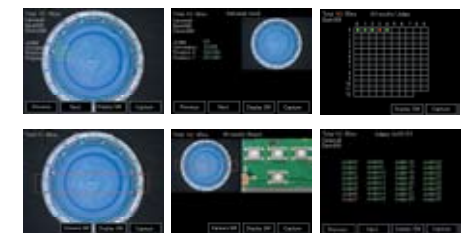

Password function

It is possible to set up a password that alters between operating mode and other. This protects against operational errors at the manufacturing site.

Display capture function

Display images can be captured and stored in the SD memory card. Useful for report documentation.

Ordering Information

Controllers

Appearance	Power supply	Circuit type	Model
	DC21.6 to 26.4V	NPN	ZFX-C20
		PNP	ZFX-C25

Cameras

Appearance	Type	Setting distance	Sensing area	Model	Remarks		
 (ZFX-SC50)	Camera with lighting	Monochrome type	34mm to 49mm	5mm x 4.9mm to 9mm x 8.9mm(variable)	ZFX-SR10	Cable length:2m	
			38mm to 194mm	10mm x 9.8mm to 50mm x 49mm(variable)	ZFX-SR50		
		Color type	34mm to 49mm	5mm x 4.9mm to 9mm x 8.9mm(variable)	ZFX-SC10		
			31mm to 187mm	10mm x 9.8mm to 50mm x 49mm(variable)	ZFX-SC50 ZFX-SC50W(IP67)		
	67mm to 142mm		50mm x 49mm to 90mm x 89mm(variable)	ZFX-SC90 ZFX-SC90W(IP67)			
	115mm to 227mm		90mm x 89mm to 150mm x 148mm(variable)	ZFX-SC150 ZFX-SC150W(IP67)			
	Camera only	Monochrome type	The CCTV lens is selected according to the range of detection and the installation distance.		ZFX-S		—
		Color type			ZFX-SC		

Cables

Type	Cable length	Model	
Camera Cable (See note 1.)	Normal type	3m,8m	ZFX-VS
	Robot cable type	3m	ZFX-VSR
Camera Extension Cable	Normal type	3m	ZFX-XC3A (See note 2.)
	Robot cable type	8m	ZFX-XC8A (See note 2.)
Parallel I/O Cable	3m	ZFX-XC3AR (See note 2.)	
Parallel I/O Cable	2m,5m	ZFX-VP	
RS-232C Cable	2m	ZFX-XPT2A	
RS-422 Cable	2m	ZFX-XPT2B	
Monitor Cable	2m,5m	FZ-VM	
Special USB cable	1.8 m	ZFX-XUSB	

Note 1: It is necessary for ZFX-S and ZFX-SC. ZFX-SR_/SC_ is a cable drawing out type, it doesn't use it.

Note 2: Up to two camera extension cables can be connected to the camera cable as long as the total cable length between the controller and the camera does not exceed 19 m.

Accessories

Type	Model	
Console	ZFX-KP (2m / 5m)	
LCD Monitor	FZ-M08	
Panel Mount Adapters	ZFX-XPM	
Optional Lighting (See note 1.)	bar lighting	ZFV-LTL01
	bar double-lighting	ZFV-LTL02
	bar low-angle lighting	ZFV-LTL04
	light source for through beam	ZFV-LTF01
CCTV Lenses /Extension Tubes	3Z4S-LE series	
External Lighting	3Z4S-LT series	
Strobe Controller (See note 2.)	Manufactured by MORITEX Corporation 3Z4S-LT MLEK-C100E1TSX	

Note 1:It is possible to ZFX-SC50 and ZFX-SC90 use it.

Note 2:It is possible to ZFX-S and ZFX-SC use it. It uses it so that the controller may control an external lighting.

Specifications

Controllers

Item	ZFX-C20	ZFX-C25		
Number of connected cameras	2			
Connectable camera	ZFX-SR_/SC_/S/SC			
Processing resolution	When ZFX-SR_/SC_ is connected:464 (H) x464 (V) When ZFX-S/SC is connected:608 (H) x464 (V)			
Display	LCD monitor	3.5" TFT color LCD (320 x 240 pixels)		
	Indicator	"Measuring" indicator (color: green): RUN Trigger indicator (color: blue): ENABLE Judgment indicator (color: orange): OUTPUT Error indicator (color: red): ERROR		
External I/F	Parallel interface	Input	12 points (RESET, DSA, DIO to 8, TRIG)	
		Output	22 points (OR, ERROR, RUN, ENABLE, GATE, STGOUT0, DO0 to 15)	
		Circuit type	NPN	PNP
	Serial interface	USB2.0	1 port, FULL SPEED, MINI-B connector	
		RS-232C	1 port, max. 115200 bps (cannot be used simultaneously with RS-422 interface)	
		RS-422	1 port, max. 115200 bps (cannot be used simultaneously with RS-232C interface)	
Network communications	Ethernet	1 port, 100BASE-TX/10BASE-T		
Monitor output	Analog RGB output, 1 ch (resolution VGA: 640 x 480)			
Memory card I/F	SD card slot 1 ch			
Operation I/F	Touch panel, key operation, console connection			
Main functions	Number of registered banks		32 banks	
	Number of setup items		128 items/1 bank	
	Measurement items	Shape inspection	Pattern search, sensitive search, flexible search, graphic search	
		Size inspection	Area, labeling	
		Edge inspection	Position, width, count	
		Brightness/color inspection	Brightness, HUE	
Application-based inspection		Defects, grouping		
Position correction	1 model search, 2 model search, position, area, labeling			
Support	Image memory function	Max. 100 images		
Menu language		Japanese/English (can be switched)		
Ratings	Power supply voltage	21.6 to 26.4 VDC (including ripple)		
	Current consumption	1.5 A max.		
	Insulation resistance	Across all lead wires and controller case: 20 M (by 250 V megger)		
	Dielectric strength	Across all lead wires and controller case, 1000 VAC, 50/60 Hz, 1 min		
Operation environment robustness	Ambient temperature range	Operating: 0 to + 50°C, Storage: -15 to +60°C (with no icing or condensation)		
	Ambient humidity range	Operating and storage: 35% to 85% (with no condensation)		
	Ambient atmosphere	No corrosive gases allowed		
	Degree of protection	IP20 (IEC60529)		
	Vibration resistance (durability)	Vibration frequency: 10 to 150 Hz Single-amplitude: 0.35 mm Acceleration: 50 m/s ² 10 times for 8 minutes		
Shock resistance (destructive)	150 m/s ² 3 times each in 6 directions (up/down, left/right, forward/backward)			
Material	Case: Polycarbonate (PC), Plate face: PMMA			
Weight	Approx. 620 g			
Accessories	Touch pen (ZFX-TP), Exhaust unit (ZFX-EU), Terminal block adapter (ZFX-XTB), Ferrite core (2 p'ces), Instruction Sheet			

Specifications

Cameras

Item	ZFX-SR10	ZFX-SR50	ZFX-SC10	ZFX-SC50 /SC50W	ZFX-SC90 /SC90W	ZFX-SC150 /SC150W	ZFX-S (monochrome type)	ZFX-SC (color type)	
Detection range (H x V)	5 mm x 4.9 mm to 9 mm x 8.9 mm (variable)	10 mm x 9.8 mm to 50 mm x 49 mm (variable)	5 mm x 4.9 mm to 9 mm x 8.9 mm (variable)	10 mm x 9.8 mm to 50 mm x 49 mm (variable)	50 mm x 49 mm to 90 mm x 89 mm (variable)	90 mm x 89 mm to 150 mm x 148 mm (variable)			
Setting distance (L)	34 mm to 49 mm	38 mm to 194 mm	34 mm to 49 mm	31 mm to 187 mm	67 mm to 142 mm	115 mm to 227 mm	The CCTV lens is selected according to the detection range and the setting distance.		
Relationship between setting distance and detection range									
Image capture element	All-pixel capture inter-line transfer type 1/3" CCD (monochrome)			All-pixel capture inter-line transfer type 1/3" CCD (color)			All-pixel capture inter-line transfer type 1/3" CCD (monochrome)	All-pixel capture inter-line transfer type 1/3" CCD (color)	
Effective number of pixels	659(H) x 494 (V)								
Pixel size	7.4 μm (H) x 7.4 μm (V)								
Shutter speed	1/170s to 1/20000s								
Partial function (partial capture)	OFF			1/2 partial, 1/4 partial			Not available	1/2 partial, 1/4 partial	
Image rate function	Fine, Normal, High speed			Not available			Fine, Normal, High speed	Not available	
Frame rate (at capture of entire screen)	96 fps			96 fps			90 fps		
Lens mount	— (with Lens)			— (with Lens)			C mount		
Lighting	Lighting method	Pulse lighting							
	LED	Red LED			White LED				
	Type	Direct lighting							
Guide light	Available (center, measurement region)			Not available					
Optional lighting I/F	Not available			Available (ZFV-LT Series)		Not available			
Indicator Class*1	—			Class 1		Class 2		Class 1	
Ratings	Power supply voltage (supplied from Controller)	15 VDC			15 VDC, 48 VDC		15 VDC, 48 VDC		
	Current consumption	Approx. 200 mA			Approx. 350 mA (15 VDC; approx. 150 mA, 48 VDC; approx. 200 mA) (including current consumption when optional lighting is connected)			Approx. 100 mA	
Operation environment	Ambient temperature range	Operating: 0 to +40°C, Storage: -20 to +65°C (with no icing or condensation)					Operating: 0 to +50°C, Storage: -20 to +65°C (with no icing or condensation)		
	Ambient humidity range	Operating and storage: 35% to 85% (with no condensation)							
	Ambient atmosphere	No corrosive gases allowed							
robustness	Degree of protection	IP65 (IEC60529)		ZFX-SC : IP65 (IEC60529), ZFX-SC W: IP67 (IEC60529)		IP20 (IEC60529)			
	Dielectric strength	1000 VAC 50 Hz/60 Hz 1 min					500VAC 50 Hz/60Hz 1 min		
	Vibration resistance (durability)	10 to 150 Hz Single-amplitude 0.35 mm 10 times for 8 min each in X, Y, and Z directions							
Shock resistance (destructive)	150 m/s ² 3 times each in 6 directions (up/down, left/right, forward/backward)								
Connection method	Cable built-in type (cable length: 2 m)					Connector connection type (camera cable ZFX-VS/VS-R required)			
Material	Case: ABS, mounting fixture: PBT					Case: Aluminum die-cast, Cover: Zinc-plated copper plate 0.5 mm thick, Camera mounting base: ABS			
Weight	Approx. 200 g (including mounting fixture and cable)		Approx. 270 g (including mounting fixture and cable)	Approx. 300 g (including mounting fixture and cable)	Approx. 600 g (including mounting fixture and cable)	Approx. 80 g			
Accessories	mounting fixture (ZFX-XMF) 1 p'ce, Ferrite core 2 p'ces, Instruction Sheet		mounting fixture (ZFX-XMF) 1 p'ce, Ferrite core 2 p'ces, Instruction Sheet	mounting fixture (ZFX-XMF2) 1 p'ce, Ferrite core 2 p'ces, Warning label 1, Instruction Sheet	mounting fixture (ZFX-XMF2) 1 p'ce, Ferrite core 2 p'ces, Warning label 1, Instruction Sheet	Ferrite core 2 p'ces, Instruction Sheet		Instruction Sheet	

*1: Applicable standards IEC60825-1:1993 +A1:1997 +A2:2001, EN60825-1:1994 +A2:2001

CCTV Lenses

Optical Graph

If using the ZFX-S/SC Camera (Camera only), refer to the optical graph below and select the lens and Extension Tubes. The lens to be selected will depend on the size of the measurement object and the camera distance.

Camera Only ZFX-S/SC

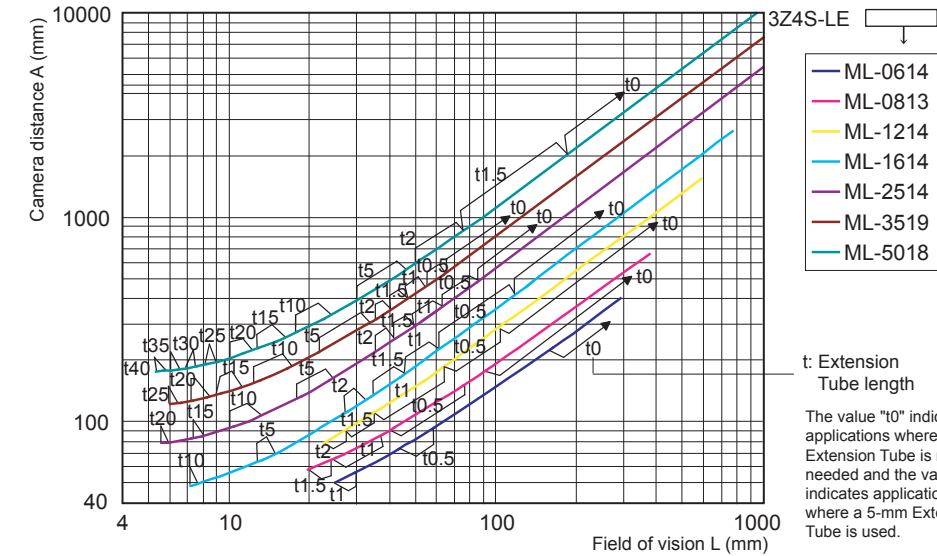

Meaning of Optical Graph

The X axis of the graph shows the field of vision L (mm), and the Y axis shows the camera distance A (mm).

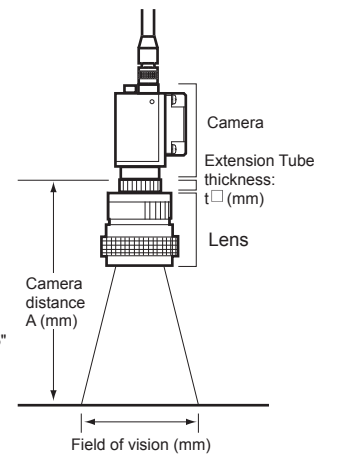

t: Extension Tube length
The value "t0" indicates applications where an Extension Tube is not needed and the value "t5" indicates applications where a 5-mm Extension Tube is used.

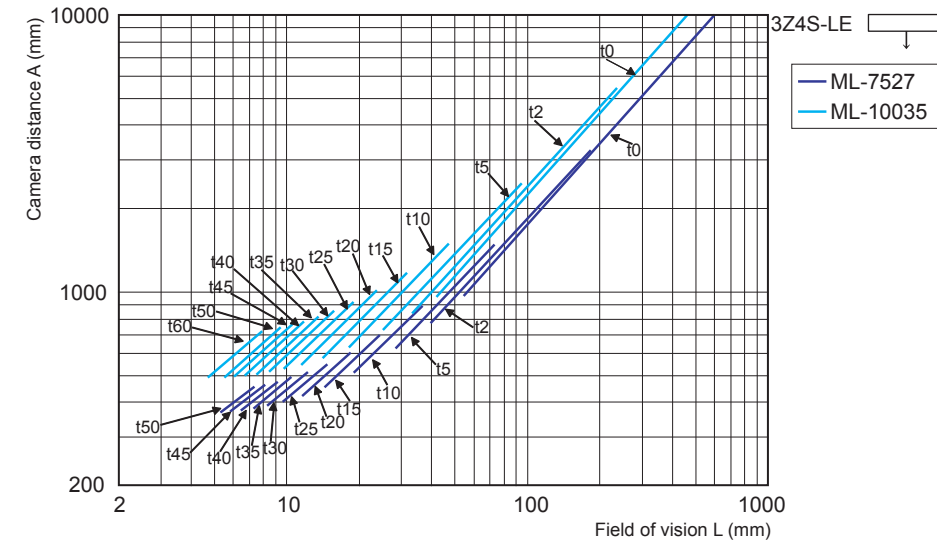

CCTV Lenses

Model	CCTV Lens								
	3Z4S-LE ML-0614	3Z4S-LE ML-0813	3Z4S-LE ML-1214	3Z4S-LE ML-1614	3Z4S-LE ML-2514	3Z4S-LE ML-3519	3Z4S-LE ML-5018	3Z4S-LE ML-7527	3Z4S-LE ML-10035
Appearance									
Focal length	6 mm	8 mm	12 mm	16 mm	25 mm	35 mm	50 mm	75 mm	100 mm
Brightness	F1.4	F1.3	F1.4	F1.4	F1.4	F1.9	F1.8	F2.7	F3.5
Filter size	M27 P0.5	M25.5 P0.5	M27 P0.5	M27 P0.5	M27 P0.5	M27 P0.5	M30.5 P0.5	M30.5 P0.5	M30.5 P0.5

Extension Tubes

Model	Contents
3Z4S-LE ML-EXR	Thickness: 40 mm 20 mm 10 mm 5 mm 2.0 mm 1.0 mm 0.5 mm Set of 7 tubes Maximum outer diameter: 30 mm dia.

Precautions

Do not use the 0.5-mm, 1.0-mm, and 2.0-mm Extension Tubes attached to each other. Since these Extension Tubes are placed over the threaded section of the Lens or other Extension Tube, the connection may loosen when more than one 0.5-mm, 1.0-mm or 2.0-mm Extension Tube are used together. Reinforcement may be required for combinations of Extension Tubes exceeding 30 mm if the Camera is subject to vibration.

