

E8F2

Pressure Sensor with Easy-to-Read LED Display

- Pressure status can be checked at a glance from the red digital pressure value and analog bar displays.
- Measurement pressure is averaged by the chattering prevention function to prevent incorrect outputs due to momentary pressure changes.
- The automatic teaching function teaches pressure values for good and bad products.
- Industry's smallest models at just 28 × 28 × 29 mm.



 Be sure to read *Safety Precautions* on page 1119.

Pressure Sensors

Ordering Information

Sensors



Pressure range		ON/OFF output	Linear output	Model	
				NPN output	PNP output
Positive pressure	0 to 100 kPa	NPN open collector (two independent outputs)	1 to 5 V	E8F2-A01C	E8F2-A01B
	0 to 1 MPa			E8F2-B10C	E8F2-B10B
Negative pressure	0 to -101 kPa			E8F2-AN0C	E8F2-AN0B

Sensing Guide

Pressure Sensors

Other Information

Accessories (Order Separately)

Appearance	Name	Model	Remarks
	Mounting Bracket	E89-F3	Provided with the E8F2.
	Panel-mounting Bracket	E89-F4	Spacer provided.

E8F2

E8MS /E8M

E8Y

E8Y□□□

Ratings and Specifications

Sensor

Item	Model	NPN output PNP output	E8F2-A01C		E8F2-B10C		E8F2-AN0C	
			E8F2-A01B		E8F2-B10B		E8F2-AN0B	
Power supply voltage			12 to 24 VDC±10% with a ripple (p-p) of 10% max.					
Current consumption			70 mA max. *1					
Pressure type			Gauge pressure					
Rated pressure range			0 to 100 kPa		0 to 1 MPa		0 to -101 kPa	
Pressure setting range			0 to 100 kPa		0 to 1 MPa		0 to -101 kPa	
Withstand pressure			400 kPa		1.5 MPa		400 kPa	
Applicable fluid			Non-corrosive gas and non-flammable gas					
Operating mode			Hysteresis mode, window mode, and automatic teaching mode					
Repeat accuracy (ON/OFF output)			±1%FS max.					
Linearity (linear output)			±1%FS max.					
Response time (ON/OFF output)			5 ms max.					
Linear output			1 to 5 V with an output impedance of 1 kΩ and a permissible resistive load of 500 kΩ.					
ON/OFF outputs			NO or NC open collector (depending on whether the output configuration is NPN or PNP)					
Load current			30 mA max.					
Output applied voltage			30 VDC max.					
Residual voltage			NPN open collector output: 1 V max. with 30 mA load current PNP open collector output: 2 V max. with 30 mA load current					
Display *2			3.5-digit red LED Green LED bar indicator The orange LED is lit for two independent outputs with output transistor turned ON. Green unit indicator					
Display accuracy			±3%FS±1 digit max.					
Protection circuits			Reverse polarity protection, load short-circuit protection					
Ambient temperature			Operating: 0 to 55°C Storage: -10 to 60°C (with no icing)					
Ambient humidity			Operating/Storage: 35% to 85% (with no condensation)					
Temperature influence			±3%FS max.					
Voltage influence			±1.5%FS max.					
Insulation resistance			100 MΩ min. (at 500 VDC) between current-carrying parts and case					
Dielectric strength			1,000 VAC at 1 min					
Vibration resistance			Destruction: 10 to 500 Hz, 1.0-mm double amplitude or 150 m/s ² , three times each for 11 min in the X, Y, and Z directions					
Shock resistance			Destruction: 300 m/s ² 3 times each in the X, Y, and Z directions					
Degree of protection			IP50 (IEC)					
Pressure port			R (PT) 1/8 taper screw and M5 female screw					
Connection method			Pre-wired (standard length: 2 m)					
Cable			Approved by UL					
Weight (packed state)			Approx. 110 g					
Material		Pressure port	Aluminum die-cast					
		Case	Heat-resistive ABS					
Accessories			Mounting Bracket, Instruction manual					

*1. The current consumption is approximately 43 mA in energy-saving mode.

*2. Display Example of Digital Indicator

Model	Setting unit				
	kPa				
	Applied pressure	Digital display			
E8F2-A01C	100	1	0	0	0 ● 0
E8F2-B10C	1000	1	0	0	0
E8F2-AN0C	-101	-1	0	1	0 ● 0

Note: The period (●) in the display indicates the decimal point.
Its position will not change unless the setting unit is changed.

Pressure
Sensors

Sensing
Guide

Pressure
Sensors

Other
Information

E8F2

E8MS
/E8M

E8Y

E8Y-□□□

E8F2

Engineering Data (Typical)

Temperature vs. Linear Output Current Fluctuation Temperature vs. Operating Pressure Fluctuation

E8F2-A01 □

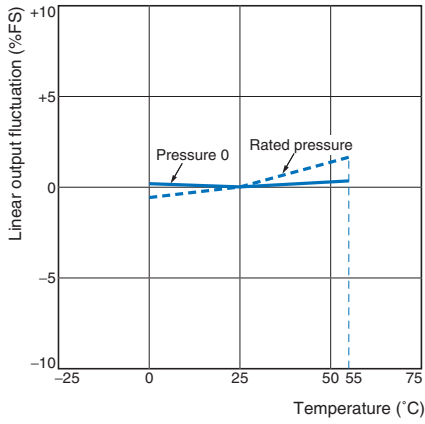

E8F2-A01 □

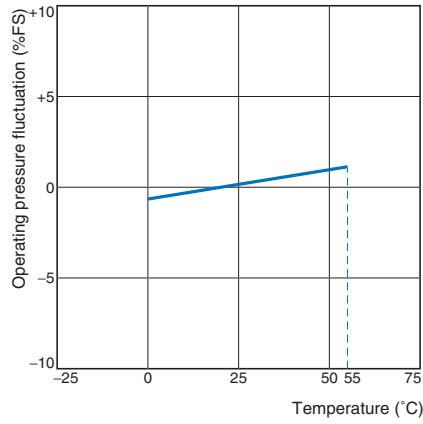

Pressure vs. Linear Output

E8F2-A01 □

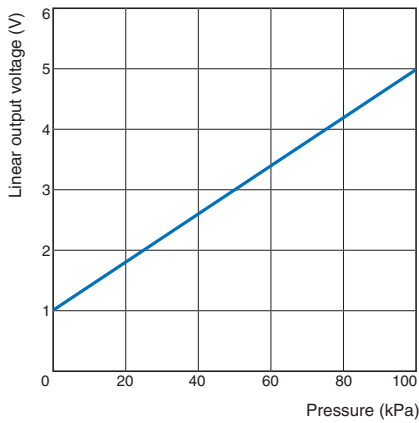

Linearity

E8F2-A01 □

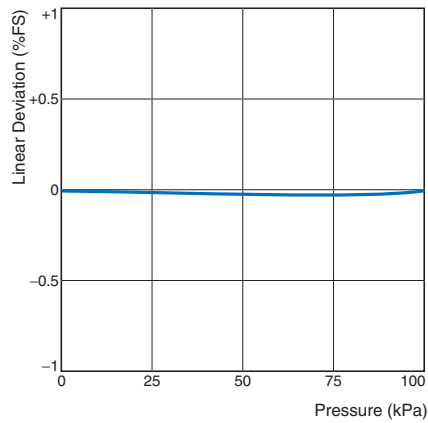

Pressure Sensors

Sensing Guide

Pressure Sensors

Other Information

E8F2

E8MS /E8M

E8Y

E8Y □-□

I/O Circuit Diagrams

NPN Output

Operating mode	Model	Timing chart		Output circuit
		Hysteresis mode	Window mode	
NO	E8F2-A01C E8F2-B10C E8F2-AN0C			
NC	E8F2-A01C E8F2-B10C E8F2-AN0C			

PNP Output

Operating mode	Model	Timing chart		Output circuit
		Hysteresis mode	Window mode	
NO	E8F2-A01B E8F2-B10B E8F2-AN0B			
NC	E8F2-A01B E8F2-B10B E8F2-AN0B			

Pressure Sensors

Sensing Guide

Pressure Sensors

Other Information

E8F2

E8MS
/E8M

E8Y

E8Y-□-F□

E8F2

Nomenclature

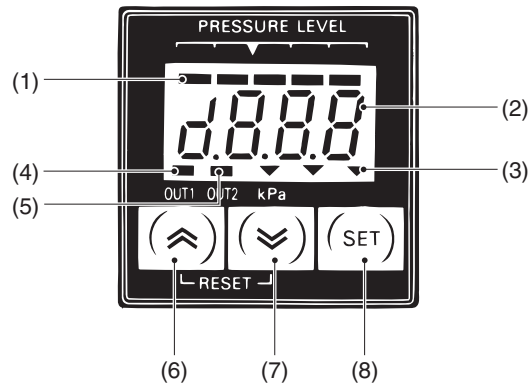

Display Panel

(1) Bar Indicator (Green)

Indicates the degree of measured pressure in relation to the set pressure.

(2) Numeric and Menu Display (Red)

Indicates measurement values and setting menu items.

(3) Unit indicator (Green)

Indicates the unit used for detection. The unit indicated on the indicator is the one currently set.

(4) OUT1 Indicator (Orange)

Lit when OUT1 is turned ON.

(5) OUT2 Indicator (Orange)

Lit when OUT2 is turned ON.

Operation Keys

(6) Up Key, (7) Down Key

- Used to select or change the set items, set contents, and set values in setting mode.
- Press either key to check the ON and OFF points in measurement mode. The values are reset by pressing both keys simultaneously.
- Use together with the SET Key for setting the Sensor to a special setting mode or energy-saving mode.

(7) SET Key

- Used for entering the set contents and set values in setting mode.
- Used for setting the Sensor to basic setting mode or pressure setting mode.

Safety Precautions

Refer to *Warranty and Limitations of Liability* on page F-2.

WARNING

This product is not designed or rated for ensuring safety of persons. Do not use it for such purpose.



Precautions for Correct Use

Do not use this product in atmospheres or environments that exceed product ratings.

● Installation

Do not use the Sensor in an environment subject to corrosive or combustible gas.

● Wiring

If no linear output is used, cut the gray lead wire short and apply insulating tape to the lead wire so that it will not come into contact with any other terminal.

● Mounting

- Do not apply a tensile strength in excess of 50 N to the cables or connectors.
- The pressure port (made of aluminum die-cast) is fixed with tapered R(PT) 1/8 male screws and M5 female screws. When using tapered screws, use tapered Rc(PT) 1/8 female screws.
- Wrap the tapered R(PT) 1/8 male screws with sealing tape to prevent any leakage. Tighten the male screws to a torque of 10 N·m max.
- Tighten M5 female screws to a torque of 2 N·m max.
- Tighten each male screw by using a 12-mm wrench to hold its hexagonal head, not its body.

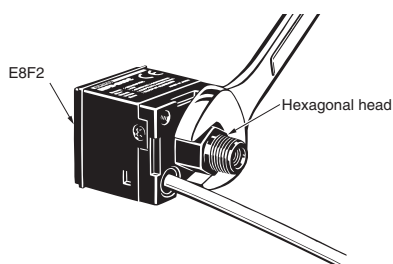

- When attaching the Mounting Bracket to the Sensor, make sure that each M3 screw is tightened to a torque of 0.5 N·m max.

● Adjustments

- Filter the gas with an appropriate air filter so that the applied gas will be free of moisture or oil.
- Be sure to use the Sensor under the rated pressure.
- When setting the set pressure of the ON or OFF point of the output transistor by pressing the mode selection key, use a manometer if precise pressure settings are required. The Sensor has a display error of 3% FS±1 digit at room temperature. Refer to *Display accuracy* in *Ratings and Specifications*.
- Turning ON the power
The Sensor is ready to operate 0.5 s after it is turned ON. When the load and Sensor are connected to separate power supplies, be sure to turn ON the Sensor first.

● Others

Make sure the Sensor does not get wet.

E8F2

Dimensions

(Unit: mm)

Sensors

E8F2

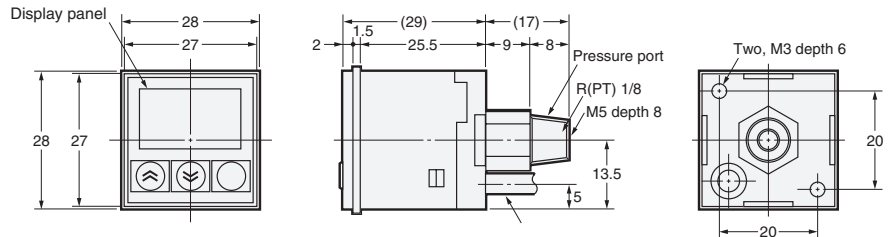
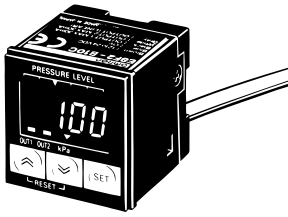

4-dia. vinyl-insulated round cable with 5 conductors
(Conductor cross-section: 0.15 mm², Insulator diameter: 0.9 mm),
Standard length: 2 m

With Mounting Bracket Attached

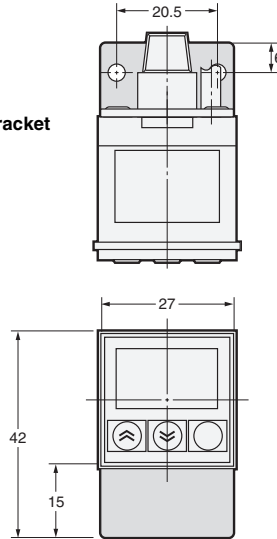

Mounting Hole Dimensions

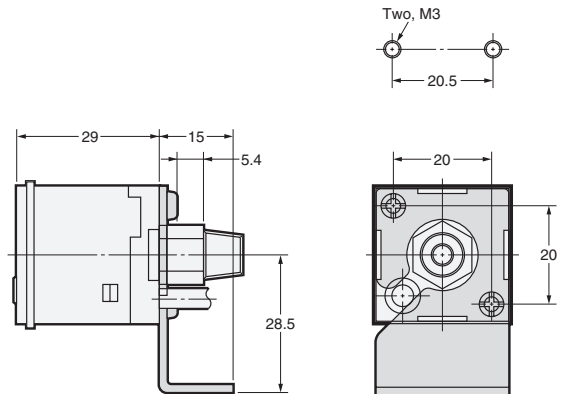

Pressure Sensors

CAD data

Sensing Guide

Accessories

Pressure Sensors

Mounting Bracket

E89-F3

Other Information

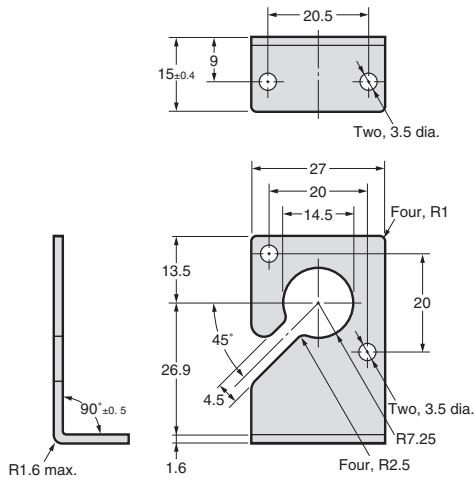
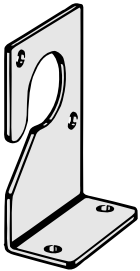

Note: Provided with the E8F2.

E8F2

E8MS /E8M

E8Y

E8Y□□□□

Panel-mounting Bracket
E89-F4

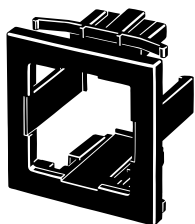

Note: Spacer provided.

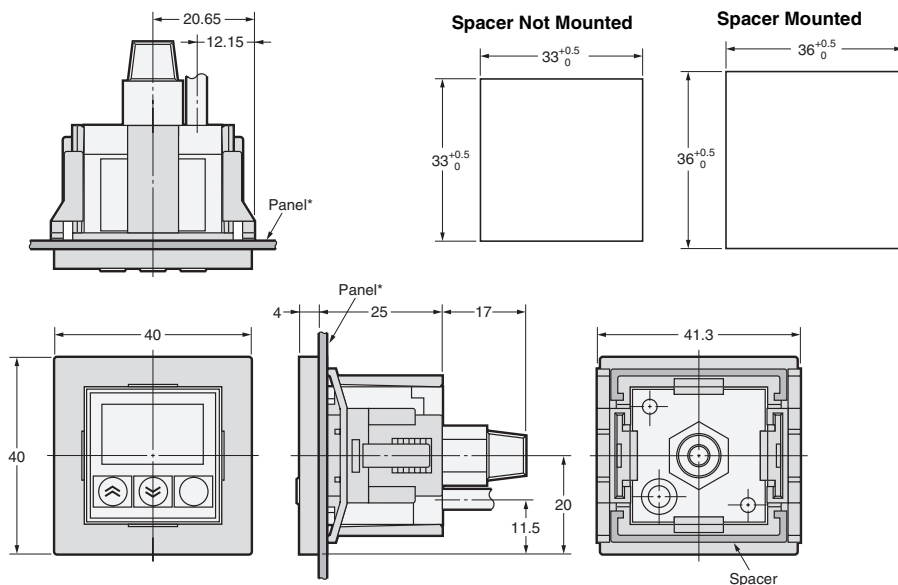

* Applicable panel thickness: 1.2 to 4 mm

Note: The spacer can be removed from the Panel-mounting Bracket. The panel cutout dimensions can be adjusted as shown above by attaching or detaching the spacer.

Pressure Sensors

Sensing Guide

Pressure Sensors

Other Information

E8F2

E8MS /E8M

E8Y

E8Y-□-F□