

World's Smallest Square Sensor with Built-in Amplifier

- 5.5 x 5.5 mm type contributes to smaller, space-saving machines and devices.
- Comprehensive range; sensing direction, size, output configuration, operation status.
- Only 2/3 the wiring process required for DC 2-wire.
- Models with different response frequency are available.
- High response frequency (1 kHz).
- Long sensing distance: (E2S-□1, 1.6 mm)
(E2S-□2, 2.5 mm)

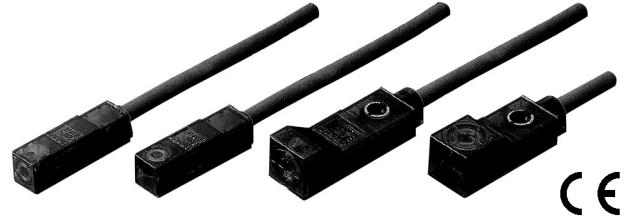

<READ AND UNDERSTAND THIS CATALOG>

Please read and understand this catalog before purchasing the products. Please consult your OMRON representative if you have any questions or comments.

Ordering Information

■ Body DC 2-wire

Appearance	Sensing surface	Sensing distance	Model	
			Operation status	
			NO (Normally Open)	NC (Normally Closed)
Non-shielded 	Front face	1.6mm	E2S-W11 (See note)	E2S-W12
	End face		E2S-Q11 (See note)	E2S-Q12
	Front face	2.5mm	E2S-W21 (See note)	E2S-W22
	End face		E2S-Q21 (See note)	E2S-Q22





DC 3-wire

Appearance	Sensing surface	Sensing distance	Output configuration	Model	
				Operation status	
				NO (Normally Open)	NC (Normally Closed)
Non-shielded 	Front face	1.6mm	NPN	E2S-W13 (See note)	E2S-W14
	End face			E2S-Q13 (See note)	E2S-Q14
	Front face	2.5mm		E2S-W23 (See note)	E2S-W24
	End face			E2S-Q23 (See note)	E2S-Q24
	Front face	1.6mm	PNP	E2S-W15 (See note)	E2S-W16
	End face			E2S-Q15 (See note)	E2S-Q16
	Front face	2.5mm		E2S-W25 (See note)	E2S-W26
	End face			E2S-Q25 (See note)	E2S-Q26

Note: Models with different in response frequency are available(NO only). These model numbers take the form of E2S-□□□B (e.g., E2S-W11B).

■ Accessories

Mounting bracket

Appearance	Model	Note
	Y92E-C1R6	Provided with E2S-□1□□
	Y92E-C2R5	Provided with E2S-□2□□
	Y92E-D1R6	
	Y92E-D2R5	

Nomenclature

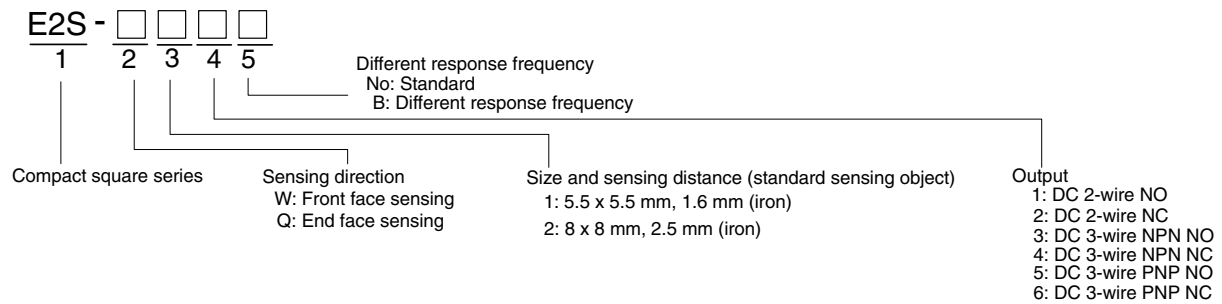

Specifications

■ Ratings/Characteristics

DC 2-wire Models

Item		E2S-W11 E2S-W12	E2S-Q11 E2S-Q12	E2S-W21 E2S-W22	E2S-Q21 E2S-Q22
Sensing surface		Front face	End face	Front face	End face
Sensing distance		1.6 mm ± 15%		2.5 mm ± 15%	
Setting distance		0 to 1.2 mm		0 to 1.9 mm	
Differential travel		10% max. of sensing distance			
Sensing object		Ferrous metal (refer to <i>Engineering Data</i> for non-ferrous metal)			
Standard sensing object		Iron, 12 × 12 × 1 mm		Iron, 15 × 15 × 1 mm	
Response frequency (see note)		1 kHz min.			
Power supply voltage (operating voltage range)		12 to 24 VDC, ripple (p-p): 10% max., (10 to 30 VDC)			
Leakage current		0.8 mA max.			
Control output	Switching capacity	3 to 50 mA DC max.			
	Residual voltage	3.0 V max. with a load current of 50 mA and a cable length of 1 m			
Indicator		<input type="checkbox"/> <input type="checkbox"/> 1 models: Operation indicator (red) Setting indicator (green) <input type="checkbox"/> <input type="checkbox"/> 2 models: Operation indicator (red)			
Operating status (with sensing object approaching)		<input type="checkbox"/> <input type="checkbox"/> 1 models: NO <input type="checkbox"/> <input type="checkbox"/> 2 models: NC Refer to <i>Output Circuits and Timing Charts</i> for details			
Circuit protection		Reverse polarity connection and surge absorber			
Ambient temperature		Operating: -25°C to 70°C (with no icing or condensation) Storage: -40°C to 85°C			
Ambient humidity		Operating: 35% to 90% (with no condensation) Storage: 35% to 95%			
Temperature influence		± 15% max. of sensing distance at 23°C in temperature range of -25°C to 70°C			
Voltage influence		± 2.5% max. of sensing distance in rated voltage range ± 10%			
Insulation resistance		50 MΩ min. (at 500 VDC) between current carry parts and case			
Dielectric strength		1,000 VAC, 50/60 Hz for 1 min between current carry parts and case			
Vibration resistance		Destruction: 10 to 55 Hz, 1.5 mm double amplitude for 2 hours each in X, Y, and Z direction			
Shock resistance		Destruction: 500 m/s ² 3 times each in X, Y, and Z direction			
Degree of protection		IEC60529 IP67 [JEM IP67 (water-tight)]			
Connection method		Pre-wired (standard length: 1 m)			
Weight (packed state)		Approx. 10 g			
Material	Case	Polyallylate resin.			
Accessories		Mounting bracket			

Note: The response frequencies of the DC switching components are average values obtained by measuring in sequence a line-up of standard sensing objects. The space between any adjacent sensing objects was twice the width of a single sensing object and the setting distance was half the maximum sensing distance.

DC 3-wire Models

Item	E2S-W13 E2S-W14	E2S-Q13 E2S-Q14	E2S-W23 E2S-W24	E2S-Q23 E2S-Q24	E2S-W15 E2S-W16	E2S-Q15 E2S-Q16	E2S-W25 E2S-W26	E2S-Q25 E2S-Q26
Sensing surface	Front face	End face	Front face	End face	Front face	End face	Front face	End face
Sensing distance	1.6 mm ± 15%		2.5 mm ± 15%		1.6 mm ± 15%		2.5 mm ± 15%	
Setting distance	0 to 1.2 mm		0 to 1.9 mm		0 to 1.2 mm		0 to 1.9 mm	
Differential travel	10% max. of sensing distance							
Sensing object	Ferrous metal (refer to <i>Engineering Data</i> for non-ferrous metal)							
Standard sensing object	Iron, 12 × 12 × 1 mm		Iron, 15 × 15 × 1 mm		Iron, 12 × 12 × 1 mm		Iron, 15 × 15 × 1 mm	
Response frequency (see note)	1 kHz min.							
Power supply voltage (operating voltage range)	12 to 24 VDC, ripple (p-p): 10% max., (10 to 30 VDC)							
Current consumption	13 mA max. at 24 VDC with no load							
Control output	Switching capacity	NPN open collector output 50 mA max. (30 VDC max.)			PNP open collector output 50 mA max. (30 VDC max.)			
	Residual voltage	1.0 V max. with a load current of 50 mA and a cable length of 1 m						
Indicator	Operation indicator (orange)							
Operating status (with sensing object approaching)	Operation indicator (orange)							
Operating status (with sensing object approaching)	<input type="checkbox"/> <input type="checkbox"/> 3 models: NO <input type="checkbox"/> <input type="checkbox"/> 4 models: NC Refer to <i>Output Circuits and Timing Charts</i> for details				<input type="checkbox"/> <input type="checkbox"/> 3 models: NO <input type="checkbox"/> <input type="checkbox"/> 4 models: NC Refer to <i>Output Circuits and Timing Charts</i> for details			
Circuit protection	Reverse polarity connection and surge absorber							
Ambient temperature	Operating: -25°C to 70°C Storage: -40°C to 85°C (with no icing or condensation)							
Ambient humidity	Operating: 35% to 90% Storage: 35% to 95% (with no condensation)							
Temperature influence	± 15% max. of sensing distance at 23°C in temperature range of -25°C to 70°C							
Voltage influence	± 2.5% max. of sensing distance in rated voltage range ± 10%							
Insulation resistance	50 MΩ min. (at 500 VDC) between current carry parts and case							
Dielectric strength	1,000 VAC, 50/60 Hz for 1 min. between current carry parts and case							
Vibration resistance	Destruction: 10 to 55 Hz, 1.5 mm double amplitude for 2 hours each in X, Y, and Z direction							
Shock resistance	Destruction: 500 m/s ² 3 times each in X, Y, and Z direction							
Degree of protection	IEC60529 IP67							
Connection method	Pre-wired (standard length: 1 m)							
Weight (packed state)	Approx. 10 g							
Material	Case	Polyallylate resin.						
Accessories	Mounting bracket							

Note: The response frequencies of the DC switching components are average values obtained by measuring in sequence a line-up of standard sensing objects. The space between any adjacent sensing objects was twice the width of a single sensing object and the setting distance was half the maximum sensing distance.

Operation

■ Output Circuits and Timing charts

DC 2-wire Models

Operation status	Model	Timing charts	Output circuits
NO	E2S-W11 E2S-W21 E2S-Q11 E2S-Q21	<p>Setting position Unstable Sensing zone Stable sensing zone Non-sensing zone Sensing object Proximity Sensor (%) 100 80 (TYP) 0 Rated sensing distance ON Setting indicator (green) OFF ON Operation indicator (red) OFF ON Control output OFF</p>	<p>The load can be connected both +V side and 0 V side</p>
NC	E2S-W12 E2S-W22 E2S-Q12 E2S-Q22	<p>Non-sensing zone Sensing zone Sensing object Proximity Sensor (%) 100 0 Rated sensing distance ON Operation indicator (red) OFF ON Control output OFF</p>	<p>The load can be connected both +V side and 0 V side</p>

DC 3-wire Models

Operation status	Output configuration	Model	Timing charts	Output circuits
NO	NPN	E2S-W13 E2S-W23 E2S-Q13 E2S-Q23	<p>Sensing object Yes No Output transistor (load) OFF ON Operation indicator (orange) ON OFF</p>	<p>Note: Maximum load current: 50 mA</p>
NC		E2S-W14 E2S-W24 E2S-Q14 E2S-Q24	<p>Sensing object Yes No Output transistor (load) ON OFF Operation indicator (orange) ON OFF</p>	
NO	PNP	E2S-W15 E2S-W25 E2S-Q15 E2S-Q25	<p>Sensing object Yes No Output transistor (load) OFF ON Operation indicator (orange) ON OFF</p>	<p>Note: Maximum load current: 50 mA</p>
NC		E2S-W16 E2S-W26 E2S-Q16 E2S-Q26	<p>Sensing object Yes No Output transistor (load) ON OFF Operation indicator (orange) ON OFF</p>	

Engineering Data

Operating Range(Typical)

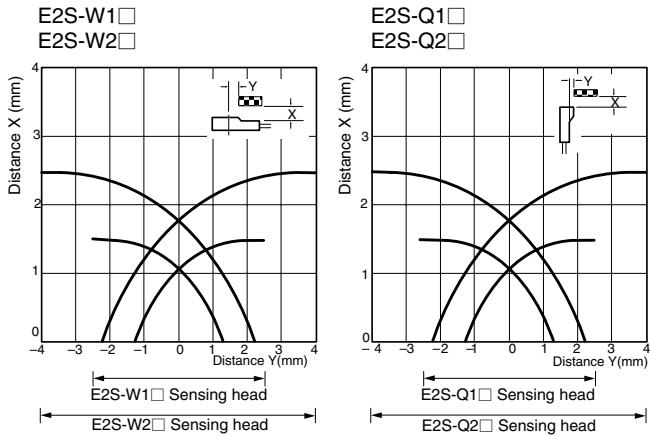

Sensing Object Size and Material vs. Sensing Distance (Typical)

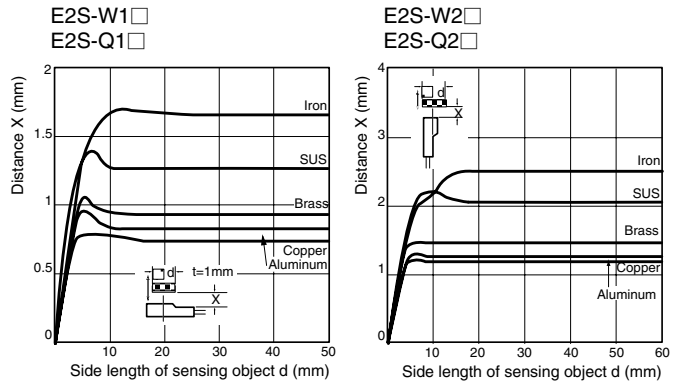

Dimensions

■ Mounting bracket

Y92E-C1R6

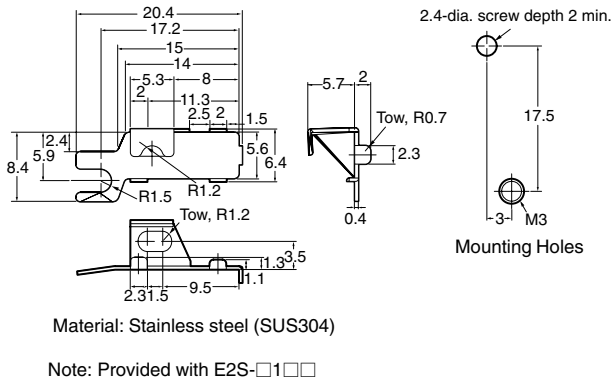

Y92E-C2R5

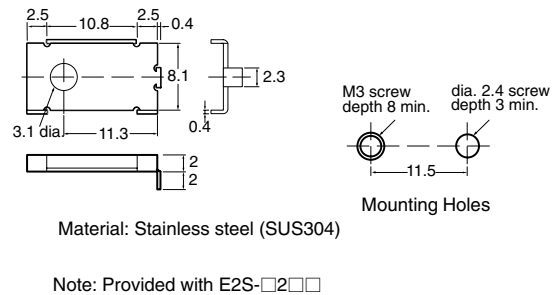

Y92E-E1R6

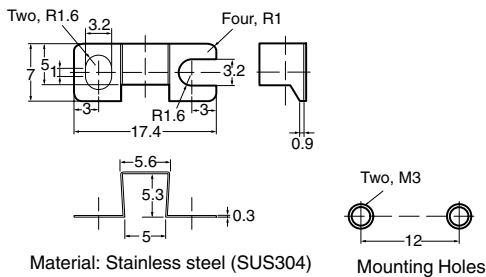

Y92E-D2R5

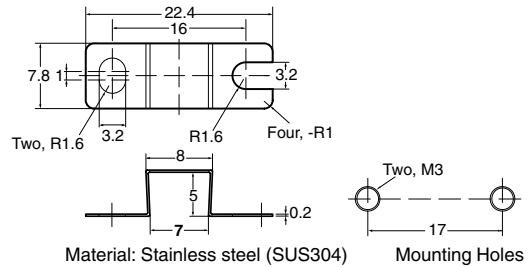

■ Body

E2S-W1 □

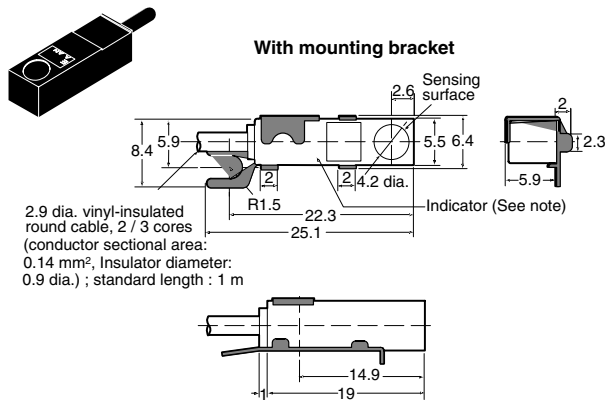

Note
E2S-W11 □:
 Operation Indicator (red)
 Setting Indicator (green)
E2S-W12 □:
 Operation Indicator (red)
E2S-W13 □, E2S-W14 □,
E2S-W15 □ and E2S-W16 □:
 Operation Indicator (orange)

E2S-Q1 □

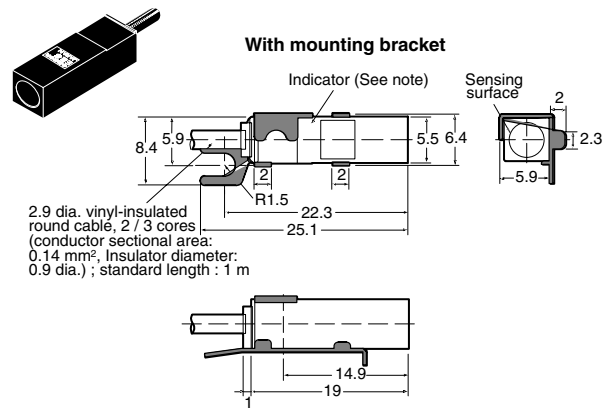

Note
E2S-Q11 □:
 Operation Indicator (red)
 Setting Indicator (green)
E2S-Q12 □:
 Operation Indicator (red)
E2S-Q13 □, E2S-Q14 □,
E2S-Q15 □ and E2S-Q16 □:
 Operation Indicator (orange)

E2S-W2 □

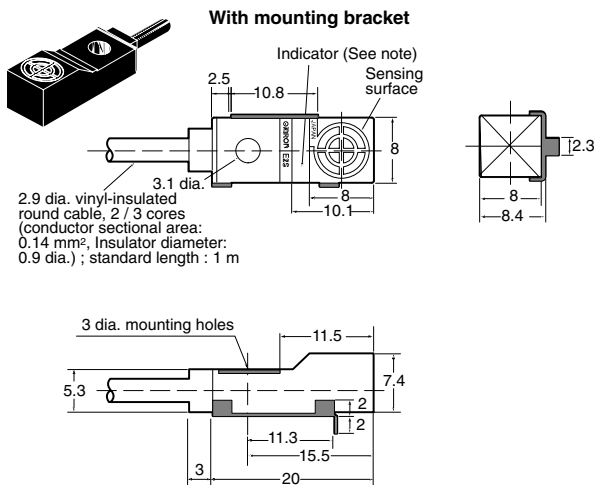

Note
E2S-W21 □:
 Operation Indicator (red)
 Setting Indicator (green)
E2S-W22 □:
 Operation Indicator (red)
E2S-W23 □, E2S-W24 □,
E2S-W25 □ and E2S-W26 □:
 Operation Indicator (orange)

E2S-Q2 □

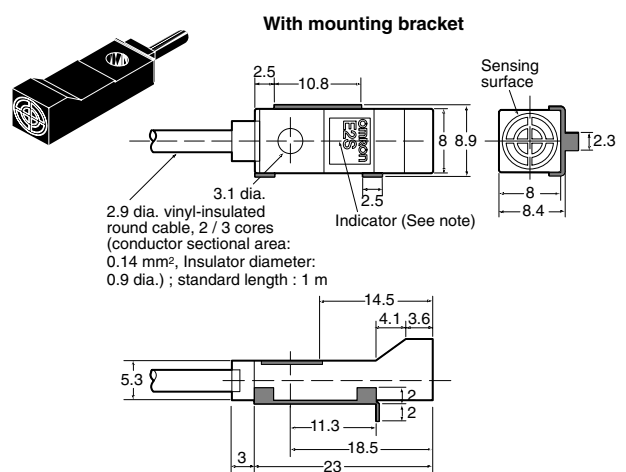

Note
E2S-Q21 □:
 Operation Indicator (red)
 Setting Indicator (green)
E2S-Q22 □:
 Operation Indicator (red)
E2S-Q23 □, E2S-Q24 □,
E2S-Q25 □ and E2S-Q26 □:
 Operation Indicator (orange)

Precautions

!
WARNING

This product is not designed or rated for ensuring safety of persons. Do not use it for such purposes.

Be sure to heed the following precautions to fully utilize the capabilities of the Sensor.

■ General

- Do not impose any voltage exceeding the rated voltage on the Sensor. Do not impose AC voltage on models that operate with DC. In both cases, the Sensor may be damaged.
- Do not short-circuit the load connected to the Sensor, otherwise the Sensor may be damaged. Load short-circuit protection functions operates during use with correct power-supply polarity in the rated voltage range.
- The load must be connected to the Sensor in operation, otherwise the Sensor may be damaged.
- When supplying power to the Sensor, make sure that the polarity of the power is correct, otherwise the Sensor may be damaged.
- Make sure to connect a proper load to the Sensor in operation, otherwise it may be damaged.
- Do not use the Sensor under the environment with explosive or ignition gas.
- Do not disassemble, repair, or modify the product.

■ Correct Use

Installation

Effects of Surrounding Metals

Provide a minimum distance as shown in the table below between the Sensor and the surrounding metal.

Front Surface Sensing Type (Not Exceeding The Height of The Sensor Head)

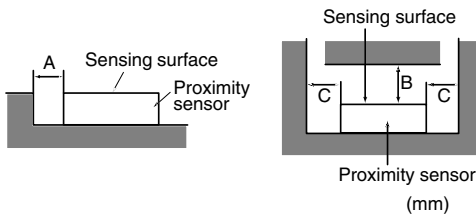

Model	A	B	C
E2S-W1 □	0	8	2
E2S-W2 □	0	15	10

End Surface Sensing Type

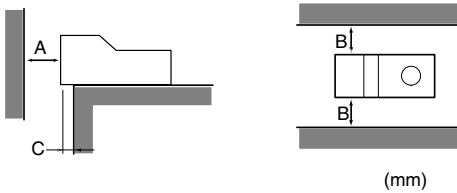

Model	A	B	C
E2S-Q1 □	8	3	2
E2S-Q2 □	15	10	3

Mutual Interference

Be sure to space the two sensors at a distance greater than that shown in the table to prevent mutual interference.

Front Surface Sensing Type

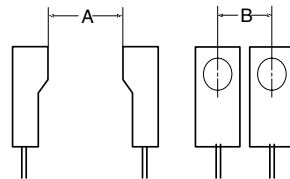

End Surface Sensing Type

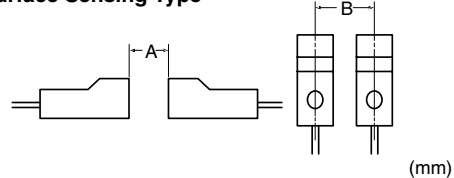

Model	A	B
E2S-W(Q)1 □	50 (40)	20 (5.5)
E2S-W(Q)2 □	75 (50)	25 (8)

Note: The above values in parentheses are applicable when using two sensors with different frequencies.

Power Reset Time

The Sensor is ready to detect objects within 100 ms after the Sensor is turned on. If the Sensor is connected to an independent power supply separately from the load, be sure to turn on the sensor first.

Power OFF

A single pulse may be output from the Sensor when the power supply is turned off. It is recommended that the load and load line are turned off first.

Power Transformer

Use only an insulated transformer for the DC power supply. Do not use an autotransformer (single-winding variable-voltage).

Wiring

Separating from High-tension Lines

Use Metal Conduit.

Pass cable through separate metal conduits to prevent malfunctioning and damage due to positioning proximity-sensor leads alongside power lines or motor lines. The same precaution applies to the DC type.

Do not pull cables with tensile strength exceeding 30 N.

Mounting

Mounting Conditions

Do not strike the Sensor with a hammer or any other tool during the installation of the Sensor, or the Sensor will lose its water-resistive properties.

Torque Exceeding

Do not tighten the E2S-W(Q)2□ mounting screws to a torque exceeding 0.7 N·m.

Maintenance and Inspection

To ensure long-term stable operation, periodically subject the proximity sensor to the same checks as all other control instruments.

Conduct the following checks.

1. Check the mounting position of the sensor relative to the detected object. Check for displacement, looseness, and deformation.
2. Check for looseness, defective contact, and discontinuities in the wiring and terminals.
3. Check for attached or accumulated metal powder.
4. Check for abnormal operating temperature and ambient temperature.
5. If the sensor has a setting display lamp, check that the lamp operates correctly.

Never disassemble or repair the sensor.

Environment

Water Resistivity

Do not use the Sensor in water, in the rain, or outdoors.

Operating Atmosphere

To ensure stable operation and long sensor life, do not operate the sensor outside the rated temperature range or in outside conditions. Although the proximity sensor has a water-resistive construction, reliability and product life can be further enhanced by installing a cover to prevent water splashing directly on the sensor. Avoid operating the sensor in an atmosphere containing chemical reagents, strong alkalis, or acids (nitric acid, chromic acid, hot concentrated sulfuric acid).

WARRANTY

OMRON's exclusive warranty is that the products are free from defects in materials and workmanship for a period of one year (or other period if specified) from date of sale by OMRON.

OMRON MAKES NO WARRANTY OR REPRESENTATION, EXPRESS OR IMPLIED, REGARDING NON-INFRINGEMENT, MERCHANTABILITY, OR FITNESS FOR PARTICULAR PURPOSE OF THE PRODUCTS. ANY BUYER OR USER ACKNOWLEDGES THAT THE BUYER OR USER ALONE HAS DETERMINED THAT THE PRODUCTS WILL SUITABLY MEET THE REQUIREMENTS OF THEIR INTENDED USE. OMRON DISCLAIMS ALL OTHER WARRANTIES, EXPRESS OR IMPLIED.

LIMITATIONS OF LIABILITY

OMRON SHALL NOT BE RESPONSIBLE FOR SPECIAL, INDIRECT, OR CONSEQUENTIAL DAMAGES, LOSS OF PROFITS OR COMMERCIAL LOSS IN ANY WAY CONNECTED WITH THE PRODUCTS, WHETHER SUCH CLAIM IS BASED ON CONTRACT, WARRANTY, NEGLIGENCE, OR STRICT LIABILITY.

In no event shall responsibility of OMRON for any act exceed the individual price of the product on which liability is asserted.

IN NO EVENT SHALL OMRON BE RESPONSIBLE FOR WARRANTY, REPAIR, OR OTHER CLAIMS REGARDING THE PRODUCTS UNLESS OMRON'S ANALYSIS CONFIRMS THAT THE PRODUCTS WERE PROPERLY HANDLED, STORED, INSTALLED, AND MAINTAINED AND NOT SUBJECT TO CONTAMINATION, ABUSE, MISUSE, OR INAPPROPRIATE MODIFICATION OR REPAIR.

SUITABILITY FOR USE

THE PRODUCTS CONTAINED IN THIS DOCUMENT ARE NOT SAFETY RATED. THEY ARE NOT DESIGNED OR RATED FOR ENSURING SAFETY OF PERSONS, AND SHOULD NOT BE RELIED UPON AS A SAFETY COMPONENT OR PROTECTIVE DEVICE FOR SUCH PURPOSES. Please refer to separate catalogs for OMRON's safety rated products.

OMRON shall not be responsible for conformity with any standards, codes, or regulations that apply to the combination of products in the customer's application or use of the product.

At the customer's request, OMRON will provide applicable third party certification documents identifying ratings and limitations of use that apply to the products. This information by itself is not sufficient for a complete determination of the suitability of the products in combination with the end product, machine, system, or other application or use.

The following are some examples of applications for which particular attention must be given. This is not intended to be an exhaustive list of all possible uses of the products, nor is it intended to imply that the uses listed may be suitable for the products:

- Outdoor use, uses involving potential chemical contamination or electrical interference, or conditions or uses not described in this document.
- Nuclear energy control systems, combustion systems, railroad systems, aviation systems, medical equipment, amusement machines, vehicles, safety equipment, and installations subject to separate industry or government regulations.
- Systems, machines, and equipment that could present a risk to life or property.

Please know and observe all prohibitions of use applicable to the products.

NEVER USE THE PRODUCTS FOR AN APPLICATION INVOLVING SERIOUS RISK TO LIFE OR PROPERTY WITHOUT ENSURING THAT THE SYSTEM AS A WHOLE HAS BEEN DESIGNED TO ADDRESS THE RISKS, AND THAT THE OMRON PRODUCT IS PROPERLY RATED AND INSTALLED FOR THE INTENDED USE WITHIN THE OVERALL EQUIPMENT OR SYSTEM.

PERFORMANCE DATA

Performance data given in this document is provided as a guide for the user in determining suitability and does not constitute a warranty. It may represent the result of OMRON's test conditions, and the users must correlate it to actual application requirements. Actual performance is subject to the OMRON Warranty and Limitations of Liability.

CHANGE IN SPECIFICATIONS

Product specifications and accessories may be changed at any time based on improvements and other reasons.

It is our practice to change model numbers when published ratings or features are changed, or when significant construction changes are made. However, some specifications of the product may be changed without any notice. When in doubt, special model numbers may be assigned to fix or establish key specifications for your application on your request. Please consult with your OMRON representative at any time to confirm actual specifications of purchased products.

DIMENSIONS AND WEIGHTS

Dimensions and weights are nominal and are not to be used for manufacturing purposes, even when tolerances are shown.

ERRORS AND OMISSIONS

The information in this document has been carefully checked and is believed to be accurate; however, no responsibility is assumed for clerical, typographical, or proofreading errors, or omissions.

PROGRAMMABLE PRODUCTS

OMRON shall not be responsible for the user's programming of a programmable product, or any consequence thereof.

ALL DIMENSIONS SHOWN ARE IN MILLIMETERS.

To convert millimeters into inches, multiply by 0.03937. To convert grams into ounces, multiply by 0.03527.

Cat. No. E902-E1-02

In the interest of product improvement, specifications are subject to change without notice.

OMRON Corporation
Industrial Automation Company

Sensing Devices Division H.Q.

Industrial Sensors Division

Shiokoji Horikawa, Shimogyo-ku,

Kyoto, 600-8530 Japan

Tel: (81)75-344-7022/Fax: (81)75-344-7107

Printed in Japan

0805-0.5C (0997) (M)