

Detects Subtle Color Differences Regardless of Workpiece Irregularities and Background Influences



Be sure to read *Safety Precautions* on page 221.



- Conformity with registered colors can be monitored on an 8-level bar (detection level) indicator.
- Allows precise settings while monitoring fine or coarse adjustments (threshold level indicators).
- Assures reliable detection with a threshold of ± 10 mm for Built-in Amplifier Models and ± 4 mm for Optical Fiber Models.
- Incorporates OMRON's unique Free Angle Optics (FAO) technology to resist changes in ambient temperature or brightness of sensing objects.
- Converts color data to analog RGB data (models with analog output)

Ordering Information

Sensors

ON/OFF Models

Red, green, or blue light

Type	No. of outputs	Appearance	Connection method	Sensing distance	Model	
					NPN output	PNP output
Built-in Amplifier Models	1			60 \pm 10 mm	E3MC-A11	E3MC-A41
	4				E3MC-MA11	E3MC-MA41
Optical Fiber Models	1		Standard connector (Sensor I/O Connector with 2-m cable provided)	20 \pm 4 mm	E3MC-X11	E3MC-X41
	4				E3MC-MX11	E3MC-MX41
General-purpose Optical Fiber Models	1			E32-CC200 5 mm	E3MC-Y11	E3MC-Y41
	4			E32-T16 200 mm		

* Eleven colors are differentiated at this distance. For a typical example, nine colors are differentiated at a sensing distance of 12 mm.

Analog Output Models

Configuration	Appearance	Sensing distance	Model
Built-in Amplifier Models		60 \pm 10 mm	E3MC-A81
Optical Fiber Models		20 \pm 4 mm	E3MC-X81
General-purpose Optical Fiber Models		Using an E32-CC200 5 \pm 1 mm	E3MC-Y81

Photo-electric Sensors

Sensing Guide

Optical Fibers

Separate Amplifiers

Built-in Amplifiers

Built-in Power Supplies

Application Specific

Peripheral Devices

Other Information

E3MC

E3C-VS /VM

F3C-AL

E3L

E3X-NL

E3S-CR62 /67

E3S-R

E3HQ

E3S-LS3

F3UV

Accessories (Order Separately)

Sensor I/O Connector

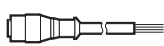
Appearance	Model	Quantity	Remarks
	E39-C1 2M (2 m)	1	Provided with the Sensor
	E39-C1 5M (5 m)	1	Order if extending a cable.

Mounting Bracket

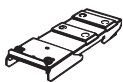
Appearance	Model	Quantity	Remarks
	E39-L114	2	When mounting the E3MC. (Can be inclined 15°)
	E39-L115	1	When mounting to a DIN track.

Note: Refer to *Mounting Brackets* on page 292.

Ratings and Specifications

ON/OFF Models

Item	Configuration Model	Built-in Amplifier Models		Optical Fiber Models		General-purpose Optical Fiber Models	
		E3MC-A□1	E3MC-MA□1	E3MC-X□1	E3MC-MX□1	E3MC-Y□1	E3MC-MY□1
Sensing distance		60±10 mm*1		20±4 mm*1		Varies with the recommended fiber. Refer to page 222 for details.	
Standard sensing object		*2					
Spot diameter		12-mm dia.		3-mm dia.		---	
Light source (wavelength)		Red (680 nm), Green (525 nm), and Blue (450 nm) LEDs					
Power supply voltage		12 to 24 VDC±10%, ripple (p-p) 10% max.					
Current consumption		100 mA max.					
Control output		Load power supply voltage: 24 VDC max., Load current: 100 mA max. Residual voltage: NPN output: 1.2 V max. PNP output: 2 V max. Open collector output					
Color discrimination mode		Mode C: RGB ratio detection Mode I: RGB light intensity detection (Switch selectable)					
Output selector		Conformity output: Output is ON when the detected color coincides with the registered color. Non-conformity output: Output is ON when the detected color does not coincide with the registered color. (switch selectable)					
Mode selection		<p>E3MC-□11/□41 Mode A (Factory-set)</p> <p>E3MC-M□11/M□41 Mode A (Factory-set)</p>					
Remote control input (mode B only)		The following control is performed according to the control signal input. <ul style="list-style-type: none"> E3MC-□11/□41□ Bank selection, remote teaching, or threshold selection E3MC-M□11/M□41□ Channel selection, remote teaching, or threshold selection 					

Photo-electric Sensors

Sensing Guide

Optical Fibers

Separate Amplifiers

Built-in Amplifiers

Built-in Power Supplies

Application Specific

Peripheral Devices

Other Information

E3MC

E3C-VS /VM

F3C-AL

E3L

E3X-NL

E3S-CR62 /67

E3S-R

E3HQ

E3S-LS3□

F3UV

E3MC

Item	Configuration Model	Built-in Amplifier Models		Optical Fiber Models		General-purpose Optical Fiber Models	
		E3MC-A□□1	E3MC-MA□□1	E3MC-X□□1	E3MC-MX□□1	E3MC-Y□□1	E3MC-MY□□1
Photo-electric Sensors	Answer-back output (mode B only)	Load current: 100 mA max. • NPN open collector output with a residual voltage of 1.2 V max. (E3MC-(M)A11/-(M)X11/-(M)Y11) • PNP open collector output with a residual voltage of 2.0 V max. (E3MC-(M)A41/-(M)X41/-(M)Y41)					
	Bank selection input (1-output model only)	4 banks selectable (either by bank selection input or by using the SELECT Button), Input response time for bank selection: 50 ms max.					
	External synchronous input	Response time: 1 ms max. (The 4-output model is not available in mode B.)					
	Protection circuits	Power supply reverse polarity protection, Output short-circuit protection					
Sensing Guide	Response time	1-output model: Standard mode: 3 ms max. High-speed mode: 1 ms max. (switch selectable) 4-output model: Standard mode: 6 ms max. High-speed mode: 2 ms max. (switch selectable)					
Optical Fibers	Discriminating color registration	Possible to register four colors in teaching operation with manual threshold level adjustments.					
Separate Amplifiers	Timer function	40-ms OFF-delay timer (ON/OFF switch selectable)					
Built-in Amplifiers	Ambient illumination (Receiver side)	Incandescent lamp: Illumination on optical spot: 3,000 lx max. Sunlight: Illumination on optical spot: 10,000 lx max.					
	Ambient temperature	Operating: -20 to 55°C, Storage: -30 to 70°C (with no icing)					
Built-in Power Supplies	Ambient humidity	Operating: 35% to 85%, Storage: 35% to 95% (with no condensation)					
	Permissible fiber bending radius	---		10 mm min.		Varies with the type of recommended fiber	
Application Specific	Insulation resistance	20 MΩ min. at 500 VDC					
	Dielectric strength	1,000 VAC, 50/60 Hz for 1 min.					
Peripheral Devices	Vibration resistance*3	Destruction: 10 to 55 Hz, 1.0-mm double amplitude or 150 m/s ² for 2 hrs each in X, Y, and Z directions					
	Shock resistance*4	Destruction: 500 m/s ² for 3 times each in X, Y, and Z directions					
Other Information	Degree of protection	IP66 (IEC 60529) (with Protective Cover in place)					
	Connection method	Standard connector (Sensor I/O Connector with 2-m cable)					
	Weight (packed state)	Approx. 350 g		Approx. 400 g		Approx. 350 g	
	Material	Case Aluminum die-cast					
		Operating Panel Cover PES					
		---		ABS		---	
	Accessories	Six M5 Phillips-head screws (with spring washers), Sensor I/O Connector with 2-m cable, Instruction manual					

*1. C mode, standard mode (response time), threshold: As a rule, 11 colors can be differentiated when $\theta=15^\circ$ (E3MC-(M)A□□) and $\theta=10^\circ$ (E3MC-(M)X□□) as shown in the following diagram.

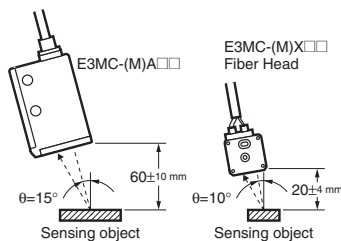

*2. Standard Sensing Object (Standard Color Card (230 Colors) for Japan Color Enterprise Co., Ltd.)

Color (11 standard colors)	Munsell color notation
White	N9.5
Red	4R 4.5/12.0
Yellow/red	4YR 6.0/11.5
Yellow	5Y 8.5/11.0
Yellow/green	3GY 6.5/10.0
Green	3G 6.5/9.0
Blue/green	5BG 4.5/10.0
Blue	3PB 5.0/10.0
Blue/purple	9PB 5.0/10.0
Purple	7P 5.0/10.0
Red/purple	6RP 4.5/12.5

*3. 0.75-mm double amplitude or 100 m/s² when using a Mounting Bracket.

*4. 300 m/s² when using a Mounting Bracket.

Photo-electric Sensors
Sensing Guide
Optical Fibers
Separate Amplifiers
Built-in Amplifiers
Built-in Power Supplies
Application Specific
Peripheral Devices
Other Information
E3MC
E3C-VS /VM
F3C-AL
E3L
E3X-NL
E3S-CR62 /67
E3S-R
E3HQ
E3S-LS3□
F3UV

Analog Output Models

Configuration		Built-in Amplifier Models	Optical Fiber Models	General-purpose Optical Fiber Models
Item	Model	E3MC-A81	E3MC-X81	E3MC-Y81
Sensing distance *1		60±10 mm	20±4 mm	5±1 mm (using the E32-CC200)
Spot diameter		12-mm dia.	3-mm dia.	Varies with the type of fiber
Light source (wavelength)		Red LED (680 nm), Green LED (525 nm), Blue LED (450 nm)		
Power supply voltage		24 VDC±10%, ripple (p-p): 10% max.		
Current consumption		100 mA max.		
Control output		3 independent analog outputs (RGB), 0 to 10 VDC output with no short-circuit protection		
	Resolution	300 mV max.		
	Load current	5 mA max.		
	Response speed	1.7 ms max.		
	Temperature characteristics	±0.3%FS/°C max.		
	Power reset time	Less than 100 ms after the power is turned ON		
Calibration inputs A and B		24 VDC		
	Signal	1 ms (24 VDC, HIGH active)		
	Response time	600 ms max.		
	Calibration value	Terminal A: 10±0.2 V		Terminal B: 7±0.2 V
Protective circuits		Power supply reverse polarity protection		
Ambient illumination (Receiver side)		Incandescent lamp: 1000 lx max.		
Ambient temperature		Operating: 0 to 50°C, Storage: -30 to 70°C (with no icing or condensation)		
Ambient humidity		Operating: 35% to 85%, Storage: 35% to 95% (with no condensation)		
Min. bending radius		---	10 mm min.	Varies with the type of fiber recommended.
Insulation resistance		20 MΩ min. at 500 VDC		
Dielectric strength		1,000 AC, 50/60 Hz for 1 min		
Vibration resistance *2		Destruction: 10 to 55 Hz, 1.0-mm double amplitude or 150 m/s ² for 2 hours each in X, Y, and Z directions		
Shock resistance *3		Destruction: 500 m/s ² 3 times each in X, Y, and Z directions		
Degree of protection		IP66 (IEC 60529) (with Protective Cover attached)		
Connection method		Special M12 Connector only		
Weight (packed state)		Approx. 300 g	Approx. 350 g	Approx. 300 g
Material	Case	Aluminum die-cast		
	Cover	PES		
	Head	ABS		
Accessories	2-m cable (E39-C1), Instruction manual			

*1. Sensing area that can be calibrated using standard white paper (N9.5).

*2. 0.75-mm double amplitude or 100m/s² when using a Mounting Bracket.

*3. 300 m/s² when using a Mounting Bracket.

Operating Procedures (Typical)

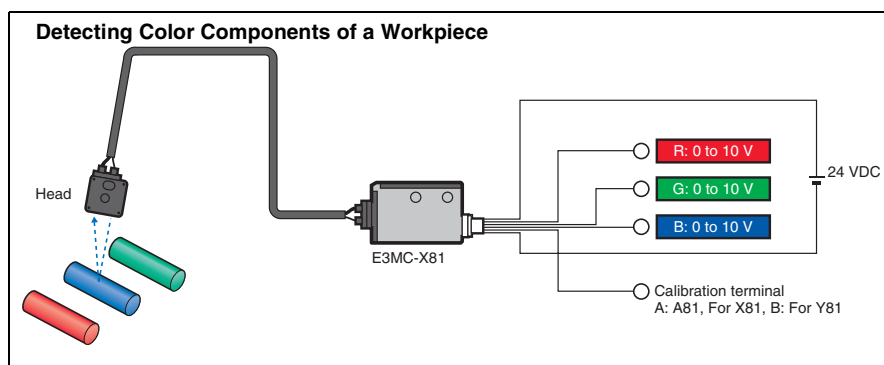

Photo-electric Sensors

Sensing Guide

Optical Fibers

Separate Amplifiers

Built-in Amplifiers

Built-in Power Supplies

Application Specific

Peripheral Devices

Other Information

E3MC

E3C-VS /VM

F3C-AL

E3L

E3X-NL

E3S-CR62 /67

E3S-R

E3HQ

E3S-LS3□

F3UV

E3MC

Engineering Data (Typical)

Built-in Amplifier and Optical Fiber Models

Sensing Distance

E3MC-(M)A□□

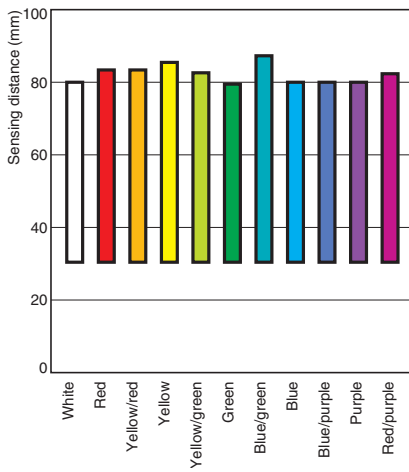

Sensing Distance

E3MC-(M)X□□

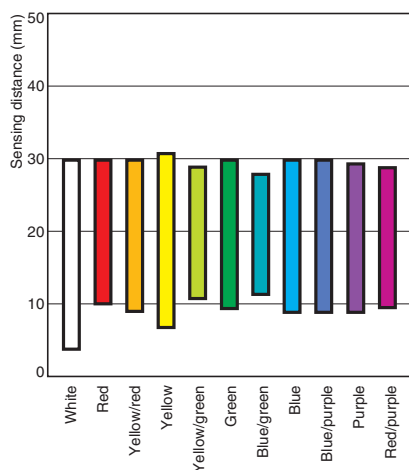

Inclination Characteristics

E3MC-(M)A□□ (X Direction)

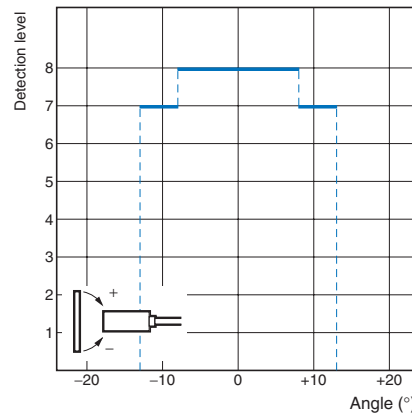

Inclination Characteristics (When Teaching at an Inclination of 15°)

E3MC-(M)A□□ (Y Direction)

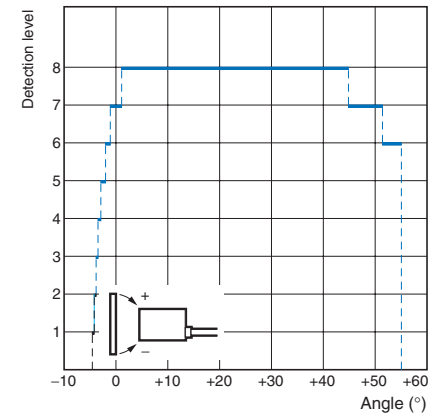

Inclination Characteristics

E3MC-(M)X□□ (X Direction)

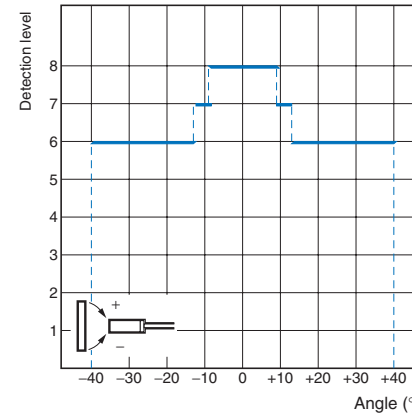

Inclination Characteristics (When Teaching at an Inclination of 10°)

E3MC-(M)X□□ (Y Direction)

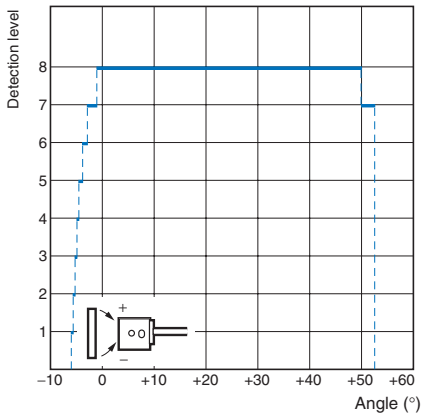

Detection Level and Indicator

Indicator	1	2	3	4	5	6	7	8
Indicator								
Detection level	1	2	3	4	5	6	7	8

Photo-electric Sensors

Sensing Guide

Optical Fibers

Separate Amplifiers

Built-in Amplifiers

Built-in Power Supplies

Application Specific

Peripheral Devices

Other Information

E3MC

E3C-VS /VM

F3C-AL

E3L

E3X-NL

E3S-CR62 /67

E3S-R

E3HQ

E3S-LS3□

F3UV

General-purpose Optical Fiber Models

Sensing Distance

E3MC-(M)Y□□ + E32-CC200

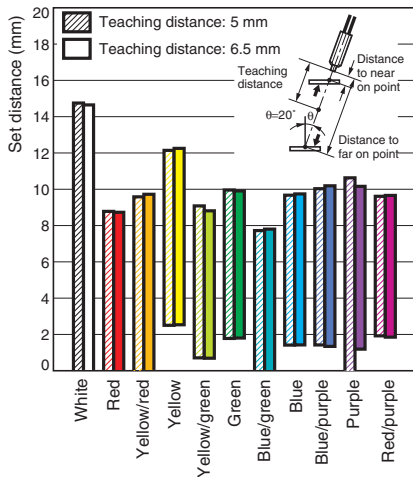

Operating Range

E32-DC200

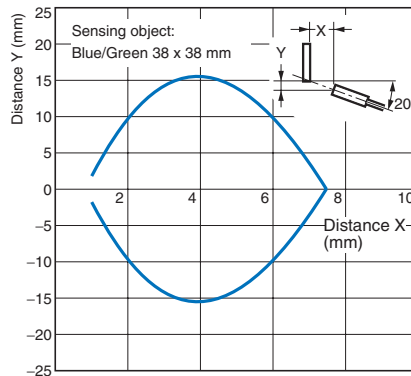

E32-CC200

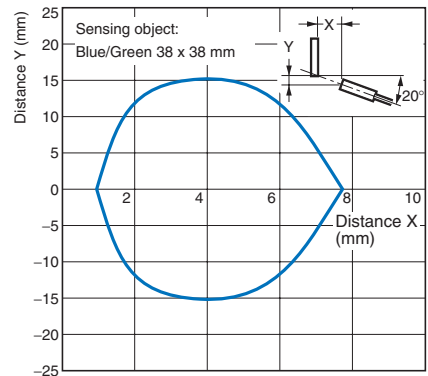

E32-D32L

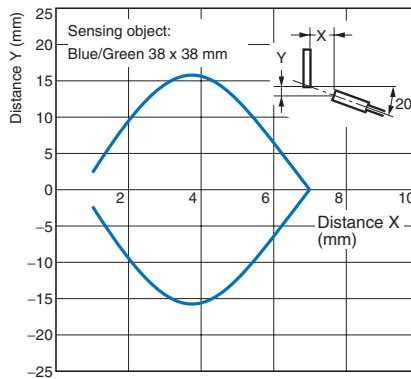

E32-D11L

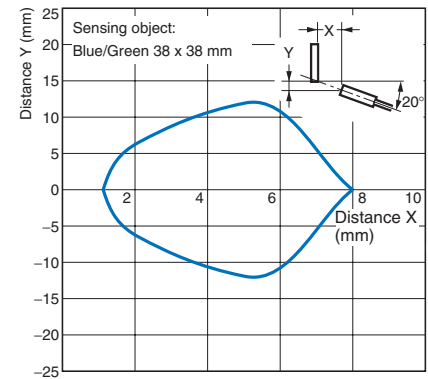

Photo-electric Sensors

Sensing Guide

Optical Fibers

Separate Amplifiers

Built-in Amplifiers

Built-in Power Supplies

Application Specific

Peripheral Devices

Other Information

E3MC

E3C-VS /VM

F3C-AL

E3L

E3X-NL

E3S-CR62 /67

E3S-R

E3HQ

E3S-LS3□

F3UV

E3MC

I/O Circuit Diagrams

ON/OFF Models

NPN Output

E3MC-□11 (1-output Models)

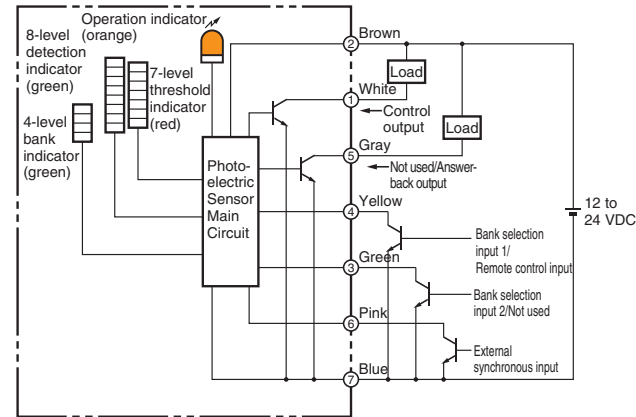

E3MC-M□11 (4-output Models)

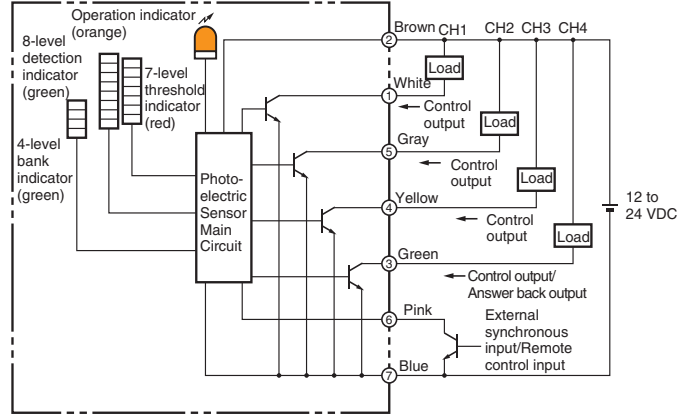

PNP Output

E3MC-□41 (1-output Model)

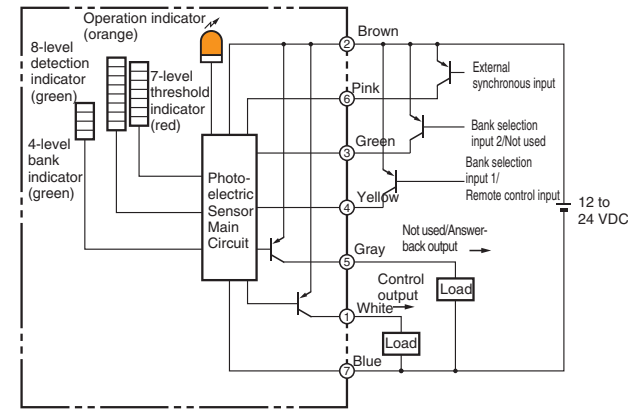

E3MC-M□41 (4-output Models)

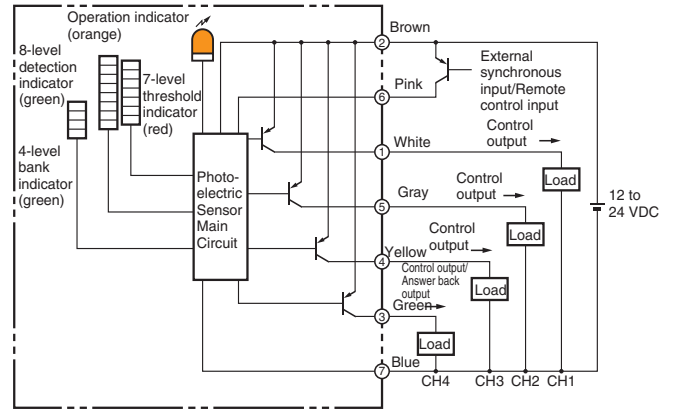

Analog Output Models

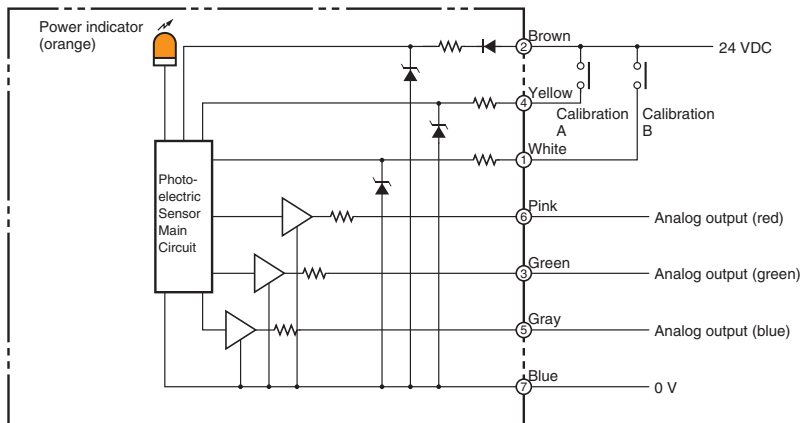

Connector Pin Arrangement



Note: Pin 8 is not used.

- Photo-electric Sensors
- Sensing Guide
- Optical Fibers
- Separate Amplifiers
- Built-in Amplifiers

- Built-in Power Supplies

- Application Specific
- Peripheral Devices
- Other Information

- E3MC
- E3C-VS /VM
- F3C-AL
- E3L
- E3X-NL
- E3S-CR62 /67
- E3S-R
- E3HQ
- E3S-LS3□
- F3UV

Timing Charts

ON/OFF Models

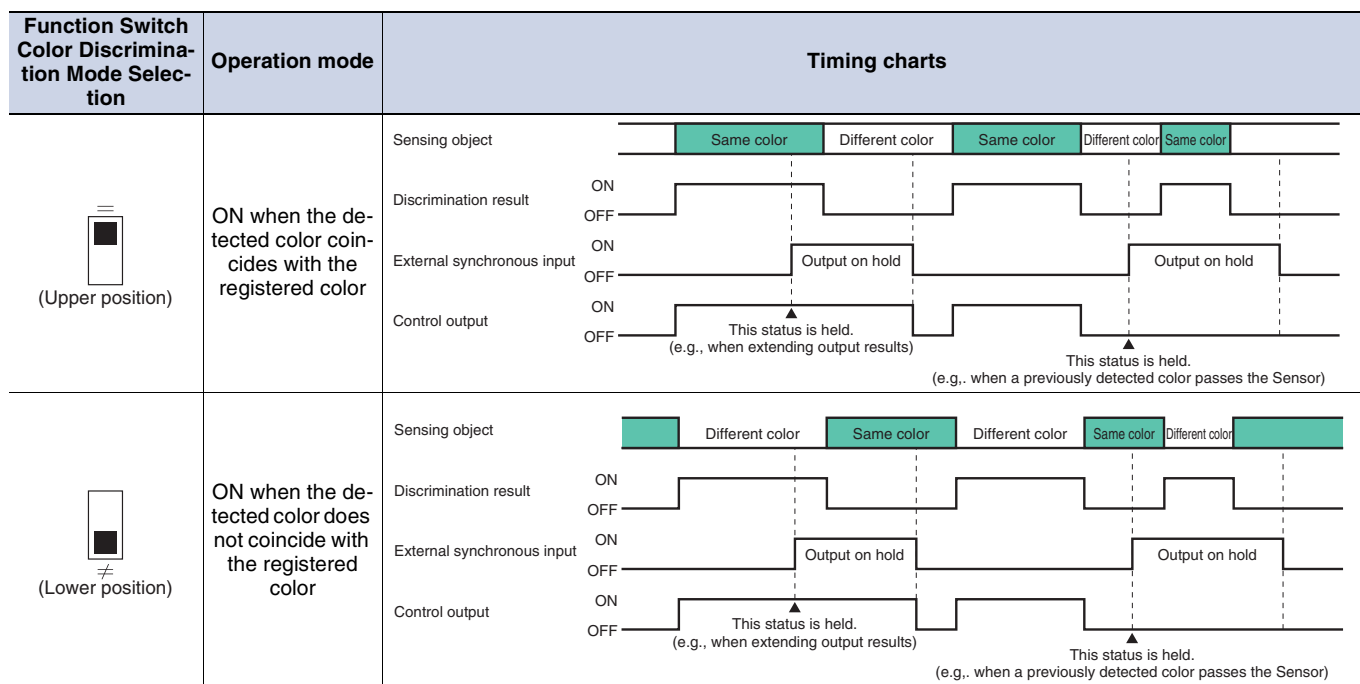

Plugs (Sensor I/O Connectors)

Model	Internal wiring	Pin no.	Wire color	ON/OFF models in A Mode		Analog output
				E3MC-□11 E3MC-□41	E3MC-M□11 E3MC-M□41	E3MC-□81
E39-C1 2M (2 m) E39-C1 5M (5 m)		1	White	Output	Output 1	Calibration B
		2	Brown	Power supply (+V)	Power supply (+V)	Power supply (+V)
		3	Green	Bank selection input 2	Output 4	Analog output G (green)
		4	Yellow	Bank selection input 1	Output 3	Calibration A
		5	Gray	---	Output 2	Analog output B (blue)
		6	Pink	External synchronous input	External synchronous input	Analog output R (red)
		7	Blue	Power supply (0 V)	Power supply (0 V)	Power supply (0 V)

Photo-electric Sensors

Sensing Guide

Optical Fibers

Separate Amplifiers

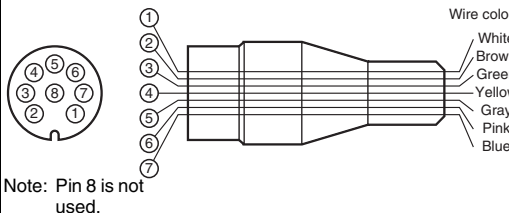
Built-in Amplifiers

Built-in Power Supplies

Application Specific

Peripheral Devices

Other Information

E3MC

E3C-VS /VM

F3C-AL

E3L

E3X-NL

E3S-CR62 /67

E3S-R

E3HQ

E3S-LS3□

F3UV

E3MC

Nomenclature

ON/OFF Models

- E3MC-A□□ (1-output Models)
- E3MC-X□□ (1-output Models)
- E3MC-Y□□ (1-output Models)

- E3MC-MA□□ (4-output Models)
- E3MC-MX□□ (4-output Models)
- E3MC-MY□□ (4-output Models)

Photo-electric Sensors

Sensing Guide

Optical Fibers

Separate Amplifiers

Built-in Amplifiers

Built-in Power Supplies

Application Specific

Peripheral Devices

Other Information

Operation Indicator (Orange)
lit when output is ON.
Under mode B, the indicator will be lit when mode B is started or when the mode selector is set to TEACH.

Bank Indicator (Green)
Displays selected bank.
TEACH Button
Registers discriminating color.

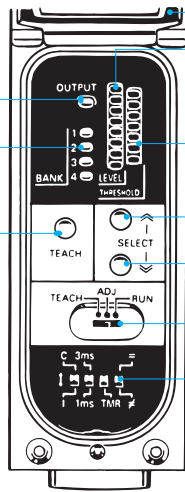

Operating Panel Cover
Detection Level Indicator (Green)
Displays similarity level between registered and detectable colors.
Threshold Indicator (Red)
Displays threshold level.
SELECT UP Button, SELECT DOWN Button
· Bank selection
· Threshold adjustment
Mode Selector
Selects TEACH, ADJ, or RUN mode.
Function Switch*
· Color discrimination mode selection
· Response time selection
· OFF-delay timer setting
· Conformity/Non-conformity output selection

Operation Indicator (Orange)
lit when output is ON.

Channel Indicator (Orange)
· Displays selected channels.
· lit when the output of each channel is ON.

TEACH Button
· Registers discriminating color.
· Used to check the number of channels that are indicated by both the operation indicator and channel indicator.

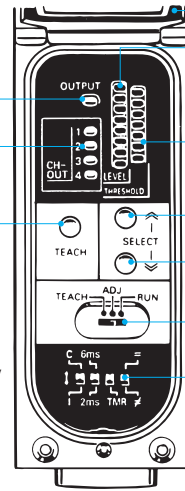

Operating Panel Cover
Detection Level Indicator (Green)
Displays similarity level between registered and detectable colors.
Threshold Indicator (Red)
Displays threshold level.
SELECT UP Button, SELECT DOWN Button
· Channel selection
· Threshold adjustment
Mode Selector
Selects TEACH, ADJ, or RUN mode.
Function Switch*
· Color discrimination mode selection
· Response time selection
· OFF-delay timer setting
· Conformity/Non-conformity output selection

*Function Switch (Function Settings)

The following settings are possible in RUN or ADJ mode. In case of 4-output models, all channels are subject to the selection of the following settings.

1. Color Discrimination Mode Selection (Mode C is Recommended for Normal Applications)

- Mode C: Color discrimination is performed according to R (red), G (green), and B (blue) ratio of the reflection light even if the sensing objects fluctuate up and down within the rated sensing range.
- Mode I: Color discrimination is performed according to RGB light intensity of reflection light. This mode ensures more delicate color discrimination than mode C.

2. Response Time Selection (Note: Figures in parentheses are for the 4-output models.)

- 3 ms (6 ms): The E3MC can stably detect minute differences of color in standard mode. Set the response time to 3 ms for usual applications.
- 1 ms (2 ms): The E3MC will be in quick-response operation. Set the response time to 1 ms if high-speed response is required.

3. OFF-delay Timer Setting

- : No OFF-delay timer is set.
- TMR: A 40-ms OFF-delay timer is set for control output.

4. Conformity/Non-conformity Output

- =: Output is ON when the detected color coincides with the registered color.
- ≠: Output is ON when the detected color does not coincide with the registered color.

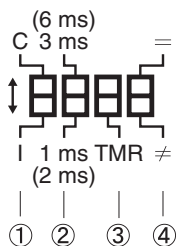

Note: Each pin of the function switch is factory-set to the upper position.

Analog Output Models

Power indicator only

E3MC

E3C-VS /VM

F3C-AL

E3L

E3X-NL

E3S-CR62 /67

E3S-R

E3HQ

E3S-LS3□

F3UV

Safety Precautions

Refer to *Warranty and Limitations of Liability* on page F-2

⚠ WARNING

This product is not designed or rated for ensuring safety of persons. Do not use it for such purpose.



Precautions for Correct Use

Do not use the product in atmospheres or environments that exceed product ratings.

Common to All E3MC Sensors

● Designing

Power Reset Time

The E3MC is ready to sense objects from 100 ms after the E3MC is turned ON, until when no devices connected the E3MC can be used. Be sure to turn ON the E3MC first if power is supplied to the E3MC and the load independently.

When using the Sensor for fine sensing, allow the system to warm up for approximately 15 min after turning ON the power supply.

Power OFF

The E3MC may output a single pulse when the control power supply is turned OFF. If the E3MC is connected to a timer or counter to which power is supplied from an independent power supply, the E3MC will be more likely to output a single pulse when the control power supply is turned OFF. Therefore, supply power to the timer or counter from the same power supply for the E3MC.

Technical Guide

Detection of Metal or Glossy Objects

Color detection can be improved by inclining the Sensor to prevent it from picking up regular reflection.

The mounting angle of the E3MC-(M)X□□ can be adjusted to approximately 10° with the mounting holes.

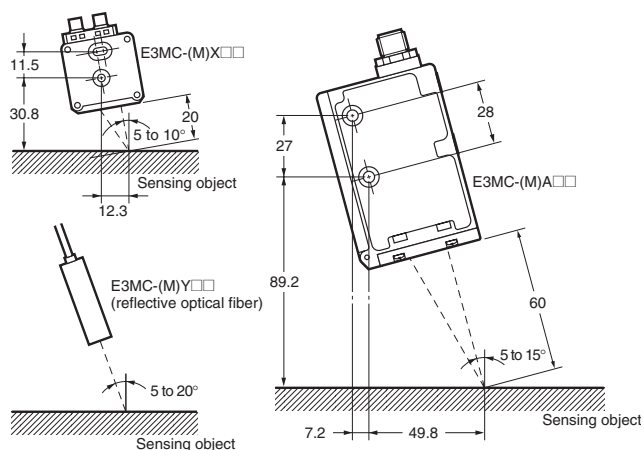

On the other hand, sensing objects such as metal or transparent plastic cases may be detected by allowing regular reflection.

Detection of White, Gray, or Black Objects

When registering white, gray, or black objects, change the color discrimination mode to Mode I to achieve a more stable color discrimination.

External Light

The E3MC may malfunction if it directly receives external light interference. Provide a cover to shut-out such external light interference.

Adjustment of Sensing Distance of General-purpose Optical Fiber Type

Unlike the E3MC-A or E3MC-X, the E3MC-Y may require adjustment of its sensing distance depending on the reflection rate. This also applies to the through-beam type.

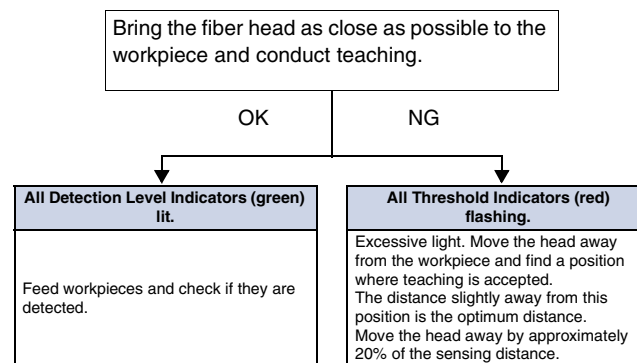

DIN Track Mounting/Removal with the E39-L115

Mounting

1. Attach the E39-L115 Mounting Bracket to the E3MC with four M5 screws.

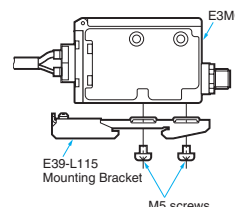

2. When mounting the E3MC with the E39-L115, loosen the M3 screw of the E39-L115 and slide part A in the direction indicated by arrow (1) as shown in the following illustration.

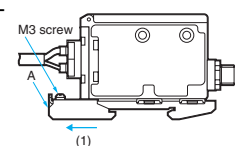

3. Mount part (2) to the DIN track.

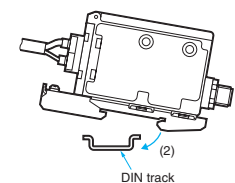

4. Press the E3MC in the direction indicated by arrow (3) and slide part A in the direction indicated by arrow (4) as shown in the following illustration until the E39-L115 correctly engages with the DIN track.

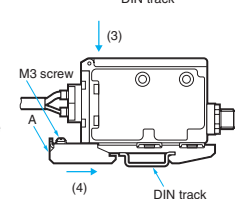

5. Tighten the M3 screw of the E39-L115 to secure the E39-L115.

Removal

Loosen the M3 screw of the E39-L115, press the E3MC in the direction indicated by arrow (5) and slide part A in the direction indicated by arrow (6). Then lift up the E3MC in the direction indicated by arrow (7) to remove the E3MC with the E39-L115.

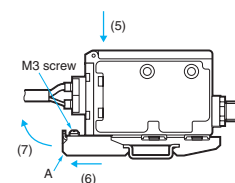

Photo-electric Sensors

Sensing Guide

Optical Fibers

Separate Amplifiers

Built-in Amplifiers

Built-in Power Supplies

Application Specific

Peripheral Devices

Other Information

E3MC

E3C-VS

/VM

F3C-AL

E3L

E3X-NL

E3S-CR62

/67

E3S-R

E3HQ

E3S-LS3□

F3UV

● Others

EEPROM Error

An EEPROM error may result if the power supply to the Sensor fails or the Sensor is influenced by static noise. The operation and bank indicators will flash and the buzzer will beep if there is an EEPROM error, in which case perform teaching and make threshold level settings again.

Protective Cover

Tighten the operation cover to a torque of 0.2 to 0.3 N·m to ensure proper waterproofing.

Built-in Amplifier Type

● Mounting

Tightening Torque

The Amplifier Unit must be tightened to a maximum torque of 2.3 N·m.

Mounting

The E3MC RGB Sensor does not have a mutual interference prevention function. For more precise detection, cover the Sensor to block out external disturbance light so the Fiber Head and lens will not pick up incandescent or fluorescent light directly.

Fiber Unit

● Mounting

Tightening Torque

When mounting the Fiber Head, tighten to a maximum torque of 0.54 N·m.

Handling the Fiber Unit

- Do not pull or press the Fiber Unit.
- Do not bend the Fiber Unit beyond the permissible bending radius given in *Ratings and Specifications*.
- Do not bend the Fiber Unit within 20 mm of the Head and Amplifier.

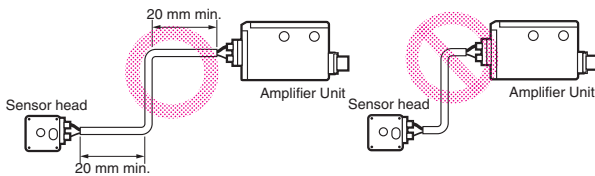

- Do not apply excess force on the Fiber Unit.

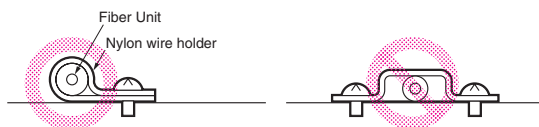

- The Fiber Head could be broken by excessive vibration. To prevent this, the following is effective:

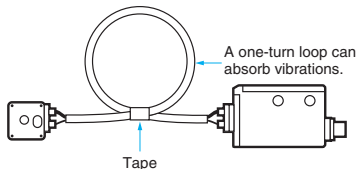

General-purpose Optical Fiber Type

● Designing

Definition of Sensing Distance of a Reflective Fiber

- The sensing distance of reflective fiber is the sensing distance of the Sensor located obliquely to the sensing object as shown in the following illustration.
- Set to C mode and standard mode (response time), and threshold set to the standard level with an inclination angle of 20 degrees ($\theta=20^\circ$).

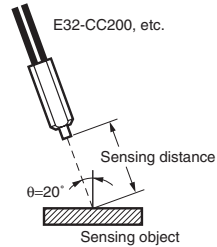

Recommended Fiber: Reflective Optical Fiber

The following optical fibers are recommended for use with the E3MC-(M)Y□□.

Model	Sensing distance*1
E32-DC200	5 mm
E32-CC200*2	5 mm
E32-D32L*3	4.5 mm
E32-D11L	5 mm

*1. The E3MC-(M)Y□□ differentiates eleven colors at the above distances. For a typical example, nine colors are discriminated at a sensing distance of 12 mm.

*2. The fiber to be inserted into the Emitter is indicated with white lines. Insert the amplifier fiber into the lower Emitter section.

*3. The fiber to be inserted into the Emitter is indicated with dotted yellow lines. Insert the amplifier fiber into the lower Emitter section.

Recommended Fiber: Through-beam Fiber

The following optical fibers are recommended for use with the E3MC-(M)Y□□.

Model	Sensing distance*
E32-TC200	30 mm
E32-T11L	60 mm
E32-T16	200 mm
E32-T17L	1.1 m

* The E3MC-(M)Y□□ differentiates red, blue, and yellow films in stable operation at the above distances.

E3MC

E3C-VS
/VM

F3C-AL

E3L

E3X-NL

E3S-CR62
/67

E3S-R

E3HQ

E3S-LS3□

F3UV

Operating Range

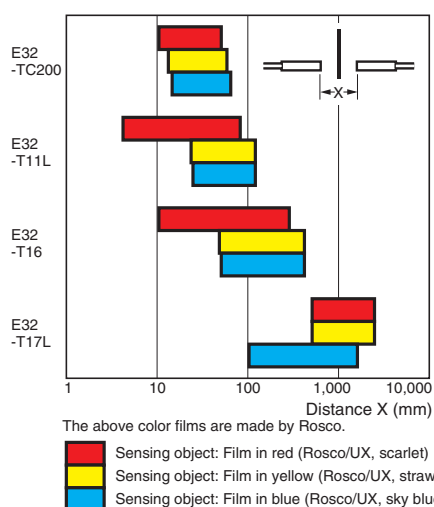

Chromatic Sensitivity

E32-T17L

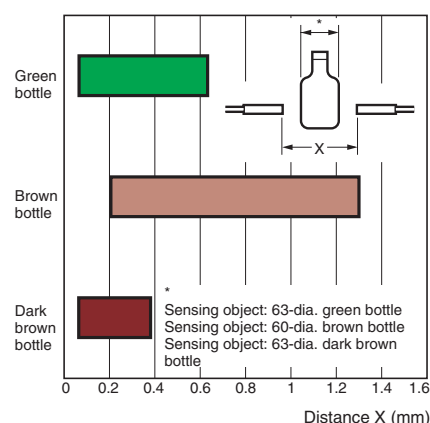

Available Optical Fibers

In addition to the previous optical fibers recommended for Reflective and Through-beam Models, the following optical fibers are also available for the E3MC-(M)Y□□. Do not use optical fibers that are not listed in the following table. Refer to pages 46 to 47 for the following optical fibers in detail.

Model	Sensing method	Remarks
E32-TC200A	Through-beam	Not different from the E32 TC200 in optical characteristics.
E32-TC200B		
E32-TC200C		
E32-TC200D		
E32-T12L		Not different from the E32-T11L in optical characteristics.
E32-T14	---	
E32-T11	---	
E32-T11R	Through-beam (R1 fiber)	---

Model	Sensing method	Remarks
E32-DC200B	Reflective	Not different from the E32-DC200 in optical characteristics.
E32-DC200C		
E32-DC200D		
E32-D12		
E32-D11	Through-beam (R1 fiber)	---
E32-D11R		
E32-G14	Groove	---

● Mounting

Insertion

The inserted Fiber Unit comes in contact with the internal rubber packing first. Insert the Fiber Unit further until it comes in contact with the innermost end.

Mounting

Tighten the Fiber Unit with a screwdriver to a torque of 0.2 N·m.

Fibers

Among the recommended fibers, the E32-CC200 and E32-D32L have white or dotted yellow lines on the fiber to be inserted into the Emitter. When using the E3MC-(M)Y□□, insert the fiber with the line into the Emitter section at the bottom of the amplifier.

Photo-electric Sensors

Sensing Guide

Optical Fibers

Separate Amplifiers

Built-in Amplifiers

Built-in Power Supplies

Application Specific

Peripheral Devices

Other Information

E3MC

E3C-VS /VM

F3C-AL

E3L

E3X-NL

E3S-CR62 /67

E3S-R

E3HQ

E3S-LS3□

F3UV

Common Items for Fiber Unit

Mounting

Tightening Torque

- When mounting the Fiber Unit, refer to the following table and make sure that the tightening torque applied is correct.

Screw-mounting Type

Column Type

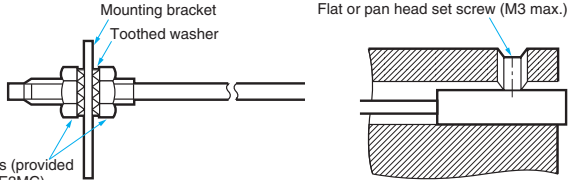

Fiber Unit	Tightening torque
M3 screw	0.78 N·m max.
M4 screw	
M6 screw	0.98 N·m max.
2-dia. column	0.29 N·m max.
3-dia. column	0.29 N·m max.
E32-T16	0.49 N·m max.

- Make sure that the size of the wrench applied to the nut is correct.

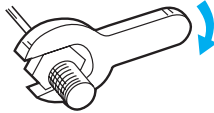

Fiber Cutting

- Insert the fiber into one of the insertion holes of the Cutting Tool to cut the fiber to the desired length.
- Press down the blade of the Cutting Tool to cut the fiber in a single stroke. Do not stop the Cutting Tool midway.
- Each insertion hole can be used only once. Do not use it again, otherwise the fiber may not be cut properly and the sensing distance may decrease.

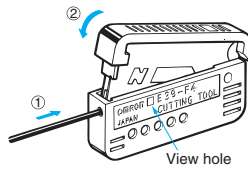

Connection

- Do not pull the Fiber Unit with force exceeding 9.8 N or press the Fiber Unit with force exceeding 29.4 N.
- Do not bend the end of the Fiber Unit.

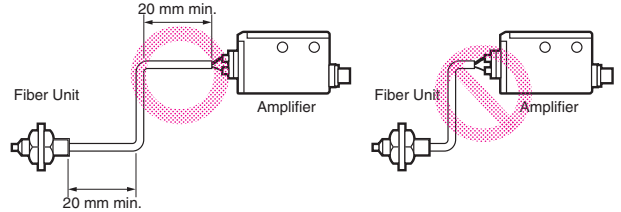

- Do not press or place a load on the Fiber Unit.

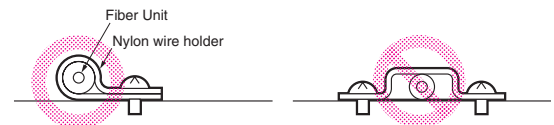

- The Fiber Head can be broken by excessive vibration. To prevent this, the following is effective.

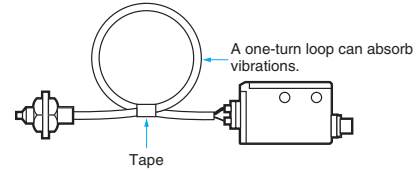

Dimensions

(Unit: mm)

Sensors

E3MC-A□□
E3MC-MA□□
E3MC-A81

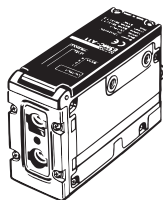

E3MC-A11

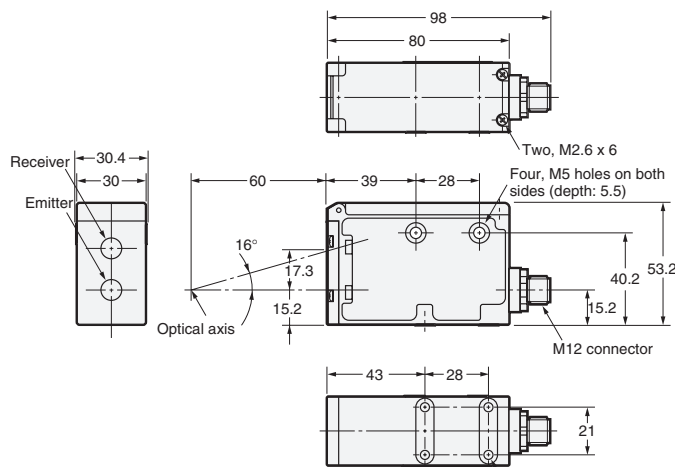

Mounting Holes

- Side Mounting

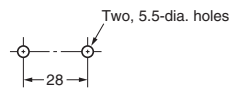

- Bottom Mounting

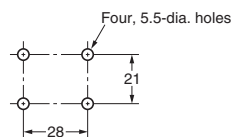

CAD data

E3MC-X□□
E3MC-MX□□
E3MC-X81

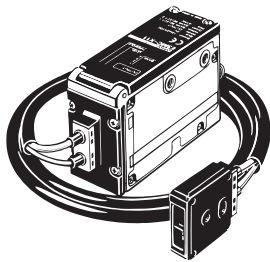

E3MC-X11

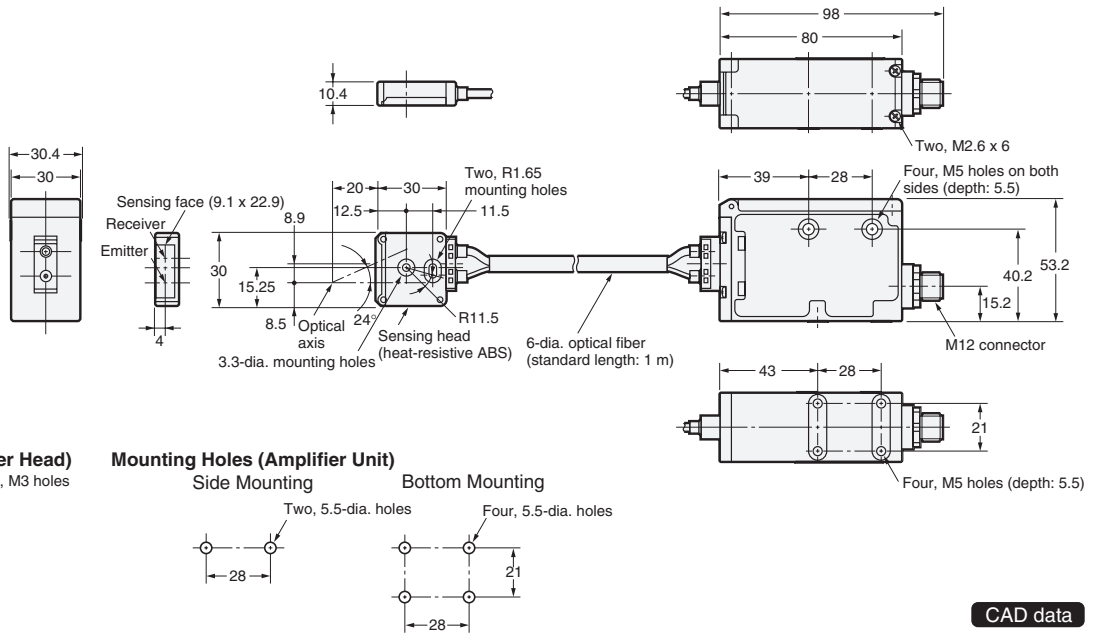

Mounting Holes (Fiber Head)

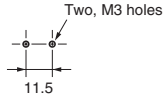

Mounting Holes (Amplifier Unit)

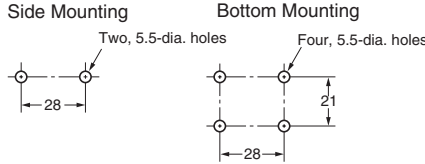

CAD data

E3MC-Y□□
E3MC-MY□□
E3MC-Y81

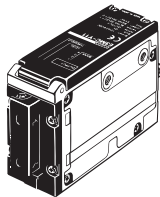

E3MC-Y11

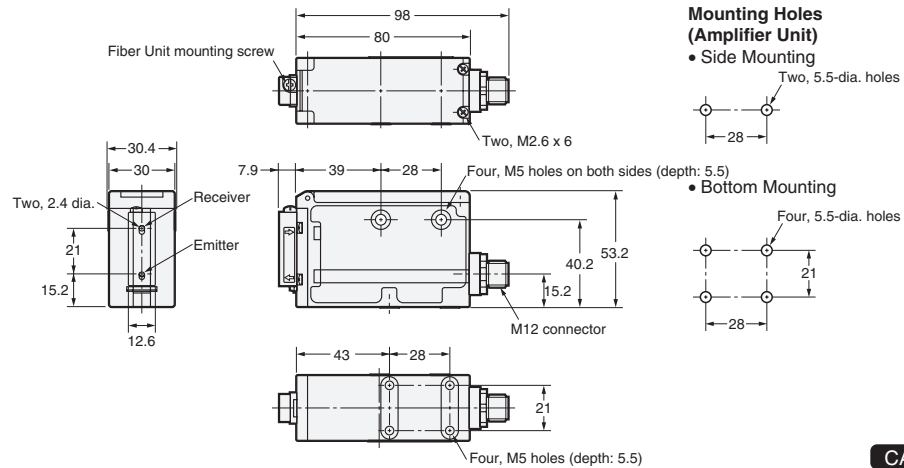

Mounting Holes (Amplifier Unit)

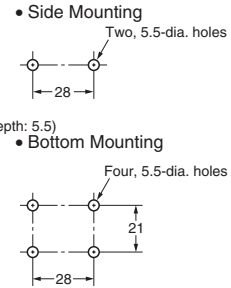

CAD data

Fiber Unit

Refer to pages 48 to 60 for details on dimensions of Fiber Units.

Accessories (Order Separately)

Sensor I/O Connectors

E39-C1 2M
E39-C1 5M

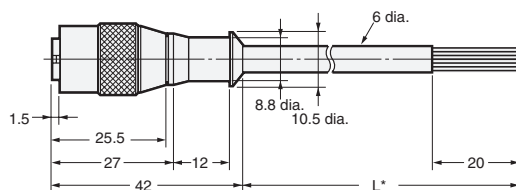

*E39-C1 2M: 2 m
E39-C1 5M: 5 m

CAD data

Note: Provided with the Sensor.

Mounting Brackets

Refer to page 292 for details.

Cat. No. E815-E1-01

In the interest of product improvement, specifications are subject to change without notice.

Photo-electric Sensors

Sensing Guide

Optical Fibers

Separate Amplifiers

Built-in Amplifiers

Built-in Power Supplies

Application Specific

Peripheral Devices

Other Information

E3MC

E3C-VS /VM

F3C-AL

E3L

E3X-NL

E3S-CR62 /67

E3S-R

E3HQ

E3S-LS3□

F3UV