

E3Z

Photo-
electric
Sensors

Sensing
Guide

Optical
Fibers

Separate
Amplifiers

Built-in
Amplifiers

Built-in
Power Supplies

Application
Specific

Peripheral
Devices

Other
Information

The New Standard for Compact, Long-range Photoelectric Sensors Conserves Energy and Natural Resources

- Long sensing distance of 15 m for Through-beam Models, 4 m for Retro-reflective Models, and 1 m for Diffuse-reflective Models.
- Unique algorithm minimizes external interference from inverter fluorescent lighting.
- Conserves energy and represents ongoing efforts aimed at eliminating materials containing lead.
- Provides a high degree of protection (IP67), IP67f oil resistance, mutual interference prevention, and EN standard compliance.
- Mechanical axis and optical axis offset always less than $\pm 2.5^\circ$ greatly simplifies optical axis alignment.





Be sure to read *Safety Precautions* on page 136.

Ordering Information

Sensors

Red light Infrared light

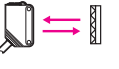
Sensing method	Appearance	Connection method	Sensing distance	Model	
				NPN output	PNP output
Through-beam		Pre-wired (2 m) *3, *4		E3Z-T61 *5 *6	E3Z-T81
		Standard M8 Connector		E3Z-T66	E3Z-T86
		Pre-wired (2 m) *3		E3Z-T61A *5	E3Z-T81A
		Standard M8 Connector		E3Z-T66A	E3Z-T86A
Oil-resistive Through-beam		Pre-wired (2 m)		E3Z-T61K	E3Z-T81K
		Pre-wired M8 Connector		E3Z-T61K-M3J	E3Z-T81K-M3J
Retro-reflective with MSR function	*1	Pre-wired (2 m) *3, *4		E3Z-R61 *5 *6	E3Z-R81
	Standard M8 Connector			E3Z-R66	E3Z-R86
Oil-resistive Retro-reflective with MSR function	*1	Pre-wired (2 m)		E3Z-R61K	E3Z-R81K
		Pre-wired M8 Connector		E3Z-R61K-M3J	E3Z-R81K-M3J
Diffuse-reflective		Pre-wired (2 m) *3, *4		E3Z-D61 *5 *6	E3Z-D81
		Standard M8 Connector		E3Z-D66	E3Z-D86
		Pre-wired (2 m) *3, *4		E3Z-D62 *5 *6	E3Z-D82
		Standard M8 Connector		E3Z-D67	E3Z-D87
Oil-resistive Diffuse-reflective		Pre-wired (2 m)		E3Z-D61K	E3Z-D81K
		Pre-wired M8 Connector		E3Z-D61K-M3J	E3Z-D81K-M3J
		Pre-wired (2 m)		E3Z-D62K	E3Z-D82K
		Pre-wired M8 Connector		E3Z-D62K-M3J	E3Z-D82K-M3J
Distance-settable Refer to page 140.		Pre-wired (2 m) *3		E3Z-LS61 *5	E3Z-LS81
		Standard M8 Connector		E3Z-LS66	E3Z-LS86

Sensing method	Appearance	Connection method	Sensing distance	Model			
				NPN output	PNP output		
Narrow-beam Reflective Refer to page 148.		Pre-wired (2 m) *3	90±30 mm			E3Z-L61 *5	E3Z-L81
		Standard M8 Connector				E3Z-L66	E3Z-L86
Retro-reflective without MSR function for clear, plastic bottles Refer to page 152.		Pre-wired (2 m) *3	500 mm (80 mm)			E3Z-B61 *5	E3Z-B81
		Standard M8 Connector				E3Z-B66	E3Z-B86
		Pre-wired (2 m) *3	2 m (500 mm)			E3Z-B62 *5	E3Z-B82
		Standard M8 Connector				E3Z-B67	E3Z-B87
Slit-type Through-beam Refer to page 156.		1 axis	25 mm			E3Z-G61 *5	E3Z-G81
		2 axes				E3Z-G62 *5	E3Z-G82
		1 axis	Pre-wired M8 Connector			E3Z-G61-M3J	E3Z-G81-M3J
		2 axes				E3Z-G62-M3J	E3Z-G82-M3J

Note: The sensing distance of Oil-resistant Retro-reflective models is different from that of standard Retro-reflective models.

*1. The Reflector is sold separately. Select the Reflector model most suited to the application.

*2. The sensing distance specified is possible when the E39-R1S used. Values in parentheses indicate the minimum required distance between the Sensor and Reflector.

*3. Models with a 0.5-m cable are available as a standard feature for products marked *3. When ordering, specify the cable length by adding the code "0.5M" to the model number (e.g., E3Z-T61 0.5M).

*4. Pre-wired M12 Connectors are available for models in the table marked *4. These models have the -M1J suffix. (Example: E3Z-T61-M1J)

*5. Press-fit e-CON Pre-wired Connectors are available with 0.3-m, 0.5-m, and 2-m cables for models in the table marked *5. The model number is E3Z-□6□-S0S□W-E□. The connector is the E-39-ECON □M with a 2-m or 5-m cable and a connector on one end or the E39-ECONW□M with a 0.5-m to 2-m cable (length increases in 0.1-m increments) and connectors at both ends. This e-CON specification is rapidly becoming the standard for FA equipment and connector manufacturers.

*6. Clamp-type e-CON Pre-wired Connectors are available with a 2-m cable. The suffix for these models is -ECON-C. (Example: E3Z-T61-ECON-C 2 M) The connectors are E-39-ECON □M with a 2-m or 5-m cable and a connector on one end or the E39-ECONW□M with a 0.5-m to 2-m cable (length increases in 0.1-m increments) and connectors at both ends. This e-CON specification is rapidly becoming the standard for FA equipment and connector manufacturers.

Accessories (Order Separately)

Slit

Slit width	Sensing distance		Minimum detectable object (typical)	Model	Contents
	E3Z-T□□	E3Z-T□□A			
0.5 mm dia.	50 mm	35 mm	0.2 mm dia.	E39-S65A	One set (contains Slits for both the Emitter and Receiver)
1 mm dia.	200 mm	150 mm	0.4 mm dia.	E39-S65B	
2 mm dia.	800 mm	550 mm	0.7 mm dia.	E39-S65C	
0.5 × 10 mm	1 m	700 mm	0.2 mm dia.	E39-S65D	
1 × 10 mm	2.2 m	1.5 m	0.5 mm dia.	E39-S65E	
2 × 10 mm	5 m	3.5 m	0.8 mm dia.	E39-S65F	

Reflectors

Name	E3Z-R Sensing distance (typical)*	Model	Quantity	Remarks
Reflector	3 m (100 mm) (rated value)	E39-R1	1	<ul style="list-style-type: none"> Retro-reflective models are not provided with Reflectors. The MSR function is enabled.
	4 m (100 mm) (rated value)	E39-R1S	1	
	5 m (100 mm)	E39-R2	1	
	2.5 m (100 mm)	E39-R9	1	
	3.5 m (100 mm)	E39-R10	1	
Fog Preventive Coating	3 m (100 mm)	E39-R1K	1	
Small Reflector	1.5 m (50 mm)	E39-R3	1	
Tape Reflector	700 mm (150 mm)	E39-RS1	1	
	1.1 m (150 mm)	E39-RS2	1	
	1.4 m (150 mm)	E39-RS3	1	

Note: 1. The actual sensing distance may be reduced to approximately 70% of the typical sensing distance when using a Reflector other than E39-R1 or E39-R1S.

2. Refer to *Reflectors* on page 295 for details.

* Values in parentheses indicates the minimum required distance between the Sensor and Reflector.

Photo-electric Sensors

Sensing Guide

Optical Fibers

Separate Amplifiers

Built-in Amplifiers

Built-in Power Supplies

Application Specific

Peripheral Devices

Other Information

E3Z

E3Z-LS

E3Z-L

E3Z-B

E3Z-G

E3T

E3S-C

E3S-CL

E3G

Mutual Interference Protection Filter

Sensing distance	Appearance/Dimensions	Model	Quantity	Remarks
3 m		E39-E11	Two sets each for the Emitter and Receiver (total of four pieces)	Can be used with the E3Z-T□□A Through-beam models. The arrow indicates the direction of polarized light. Mutual interference can be prevented by altering the direction of polarized light from or to adjacent Emitters and Receivers.

Mounting Brackets

Appearance	Model	Quantity	Remarks	Appearance	Model	Quantity	Remarks
	E39-L153	1	Mounting Brackets *		E39-L98	1	Metal Protective Cover Bracket *
	E39-L104	1			E39-L150	1 set	(Sensor adjuster)
	E39-L43	1	Horizontal Mounting Brackets *		E39-L151	1 set	Easily mounted to the aluminum frame rails of conveyors and easily adjusted.
	E39-L142	1	Horizontal Protective Cover Bracket*				For left to right adjustment
	E39-L44	1	Rear Mounting Bracket *		E39-L144	1	Compact Protective Cover Bracket (For E3Z only) *

Note: 1. When using Through-beam models, order one bracket for the Receiver and one for the Emitter.
 2. Refer to *Mounting Brackets* on page 292 for details.
 * Cannot be used for Standard Connector models.

Sensor I/O Connectors

Size	Cable	Appearance	Cable type	Model	
M8	Standard	Straight	 2 m 5 m	4-wire	XS3F-M421-402-A
					XS3F-M421-405-A
		L-shaped	 2 m 5 m	XS3F-M422-402-A	
				XS3F-M422-405-A	
M12 (For -M1J models)		Straight	 2 m 5 m	3-wire	XS2F-D421-DC0-A
					XS2F-D421-GC0-A
		L-shaped	 2 m 5 m		XS2F-D422-DC0-A
					XS2F-D422-GC0-A

Note: Refer to *Sensor I/O Connectors* on page 1182.

Ratings and Specifications

Item	Model	Sensing method		Through-beam		Retro-reflective with MSR function		Diffuse-reflective	
		NPN output	E3Z-T61(K)/T66	E3Z-T61A/T66A	E3Z-R61/R66	E3Z-R61K	E3Z-D61(K)/D66	E3Z-D62(K)/D67	
		PNP output	E3Z-T81(K)/T86	E3Z-T81A/T86A	E3Z-R81/R86	E3Z-R81K	E3Z-D81(K)/D86	E3Z-D82(K)/D87	
Sensing distance			15 m	10 m	4 m (100 mm)* (when using E39-R1S) 3 m (100 mm)* (when using E39-R1)	3 m (150 mm)* (when using E39-R1S) 2 m (100 mm)* (when using E39-R1)	White paper (100 × 100 mm): 100 mm	White paper (300 × 300 mm): 1 m	
Spot diameter			---						
Standard sensing object			Opaque: 12-mm dia. min.		Opaque: 75-mm dia. min.		---		
Minimum detectable object			---						
Differential travel			---				20% max. of setting distance		
Directional angle			Both emitter and receiver: 3 to 15°	Both emitter and receiver: 3 to 15°	2 to 10°		---		
Light source (wavelength)			Infrared LED (870 nm)	Red LED (660 nm)	Red LED (660 nm)		Infrared LED (860 nm)		
Power supply voltage			12 to 24 VDC±10%, ripple (p-p): 10% max.						
Current consumption			Emitter: 15 mA Receiver: 20 mA		30 mA max.				
Control output			Load power supply voltage: 26.4 VDC max., Load current: 100 mA max. Residual voltage: Load current of less than 10 mA: 1 V max. Load current of 10 to 100 mA: 2 V max. Open collector output (NPN/PNP depending on model) Light-ON/Dark-ON selectable						
Protection circuits			Reversed power supply polarity protection, Output short-circuit protection, and Reversed output polarity protection		Reversed power supply polarity protection, Output short-circuit protection, Mutual interference prevention, and Reversed output polarity protection				
Response time			Operate or reset: 1 ms max.						
Sensitivity adjustment			One-turn adjuster						
Ambient illumination (Receiver side)			Incandescent lamp: 3,000 lx max. Sunlight: 10,000 lx max.						
Ambient temperature			Operating: -25 to 55°C, Storage: -40 to 70°C (with no icing or condensation)						
Ambient humidity			Operating: 35% to 85%, Storage: 35% to 95% (with no condensation)						
Insulation resistance			20 MΩ min. at 500 VDC						
Dielectric strength			1,000 VAC, 50/60 Hz for 1 min						
Vibration resistance			Destruction: 10 to 55 Hz, 1.5-mm double amplitude for 2 hours each in X, Y, and Z directions						
Shock resistance			Destruction: 500 m/s ² 3 times each in X, Y, and Z directions						
Degree of protection			IP67 (IEC 60529), Oil resistive models: IP67 (IEC 60529) (JEM standard: IP67f, excluding cables and connectors)						
Connection method			Pre-wired cable (standard length: 2 m or 500 mm), Standard M8 Connector, Pre-wired M8 Connector (Oil-resistive models only)						
Indicator			Operation indicator (orange) Stability indicator (green) Emitter has power indicator (orange) only.						
Weight (packed state)	Pre-wired cable (2 m)		Approx. 120 g		Approx. 65 g				
	Standard Connector		Approx. 30 g		Approx. 20 g				
	Pre-wired M8 Connectors (oil-resistive models only)		Approx. 50 g		Approx. 30 g				
Material	Case		PBT (polybutylene terephthalate)						
	Lens		Modified polyarylate resin		Methacrylic resin		Modified polyarylate resin		
Accessories			Instruction manual (Neither Reflectors nor Mounting Brackets are provided with any of the above models.)						

Note: Oil-resistive Retro-reflective models have a different sensing distance than standard Retro-reflective models.

* Values in parentheses indicate the minimum required distance between the Sensor and Reflector.

Photo-electric Sensors

Sensing Guide

Optical Fibers

Separate Amplifiers

Built-in Amplifiers

Built-in Power Supplies

Application Specific

Peripheral Devices

Other Information

E3Z

E3Z-LS

E3Z-L

E3Z-B

E3Z-G

E3T

E3S-C

E3S-CL

E3G

E3Z

Engineering Data (Typical)

Parallel Operating Range

Through-beam Models

E3Z-T□1(R□6)

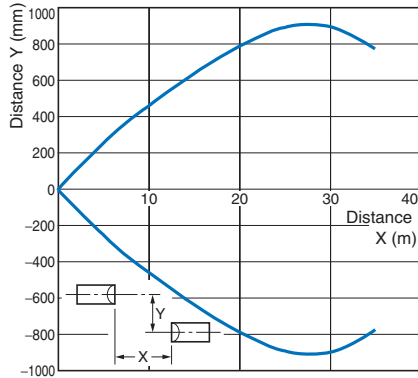

Through-beam Models

E3Z-T□A

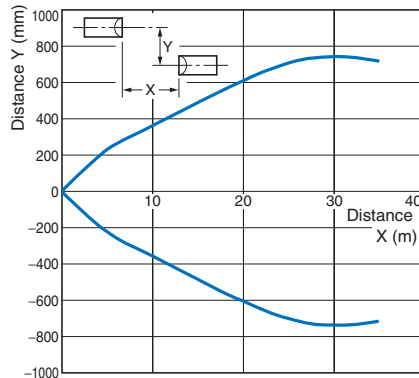

Retro-reflective Models

E3Z-R□1(R□6) and Reflector

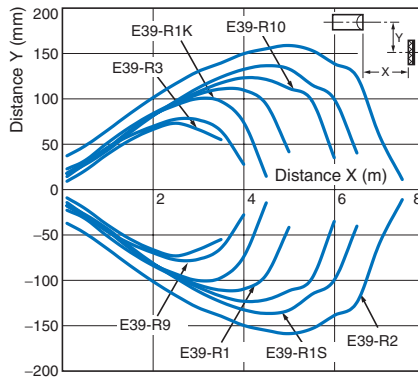

Operating Range

Diffuse-reflective Models

E3Z-D□1(D□6)

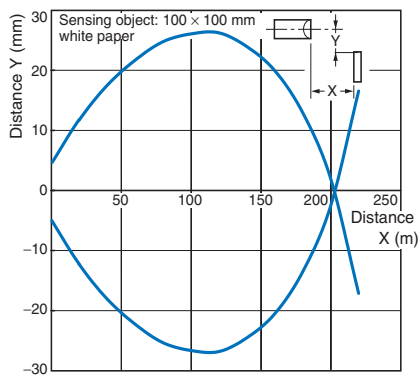

Diffuse-reflective Models

E3Z-D□2(D□7)

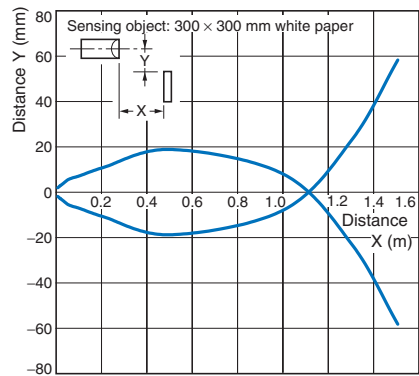

Photo-electric Sensors

Sensing Guide

Optical Fibers

Separate Amplifiers

Built-in Amplifiers

Built-in Power Supplies

Application Specific

Peripheral Devices

Other Information

E3Z

E3Z-LS

E3Z-L

E3Z-B

E3Z-G

E3T

E3S-C

E3S-CL

E3G

Excess Gain vs. Set Distance

Through-beam Models

E3Z-T□1(T□6)

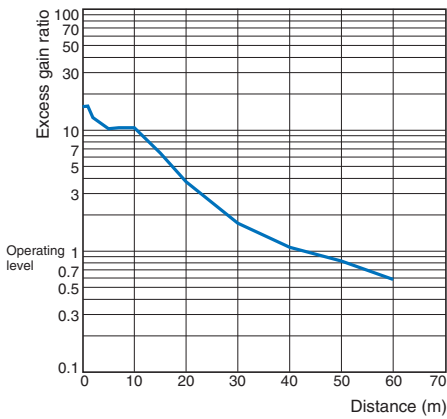

Through-beam Models

E3Z-T□A

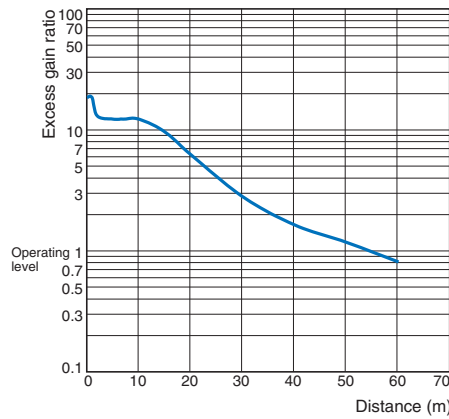

Retro-reflective Models

E3Z-R□1(R□6) and Reflector

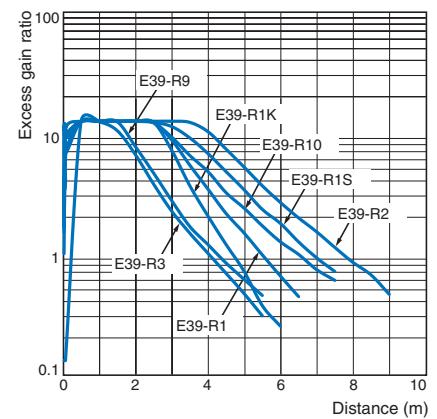

Diffuse-reflective Models

E3Z-D□1(D□6)

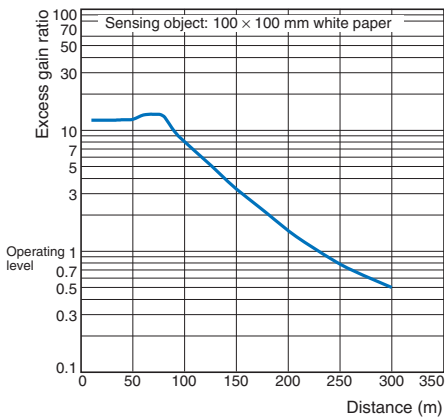

Diffuse-reflective Models

E3Z-D□2(D□7)

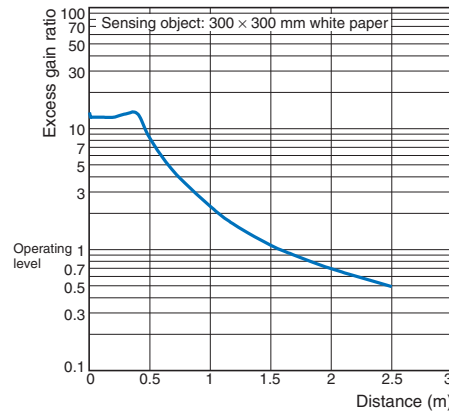

Sensing Object Size vs. Sensing Distance

Diffuse-reflective Models

E3Z-D□1(D□6)

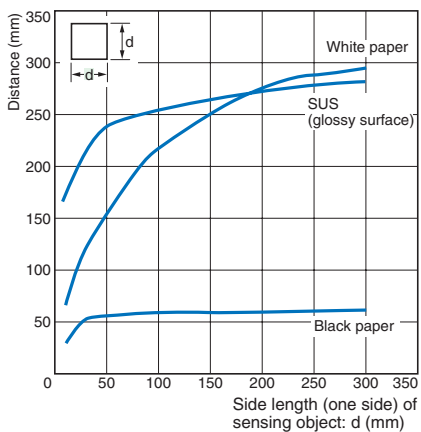

Diffuse-reflective Models

E3Z-D□2(D□7)

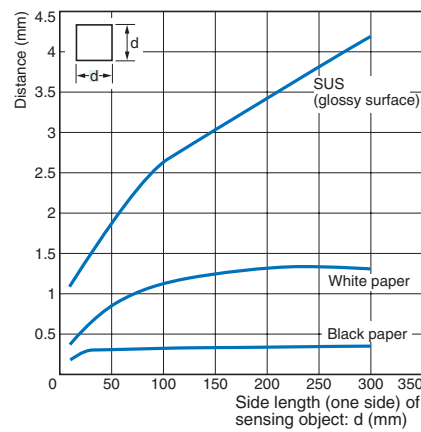

Photo-electric Sensors

Sensing Guide

Optical Fibers

Separate Amplifiers

Built-in Amplifiers

Built-in Power Supplies

Application Specific

Peripheral Devices

Other Information

E3Z

E3Z-LS

E3Z-L

E3Z-B

E3Z-G

E3T

E3S-C

E3S-CL

E3G

E3Z

I/O Circuit Diagrams

NPN Output

Model	Operation mode	Timing charts	Mode selector switch	Output circuit
E3Z-T61(K) E3Z-T66 E3Z-T61A E3Z-T66A E3Z-R61(K) E3Z-R66 E3Z-D61(K) E3Z-D66 E3Z-D62(K) E3Z-D67	Light-ON	Incident light No incident light Operation indicator ON Operation indicator (orange) OFF Output transistor ON Output transistor OFF Load Operate (e.g., relay) Reset (Between brown and black leads)	L side (LIGHT ON)	Through-beam Receivers, Retro-reflective Models, Diffuse-reflective Models.
	Dark-ON	Incident light No incident light Operation indicator ON Operation indicator (orange) OFF Output transistor ON Output transistor OFF Load Operate (e.g., relay) Reset (Between brown and black leads)	D side (DARK ON)	Connector Pin Arrangement Pin 2 is not used. e-CON Connector Pin Arrangement
Through-beam Emitter				

PNP Output

Model	Operation mode	Timing charts	Mode selector switch	Output circuit
E3Z-T81(K) E3Z-T86 E3Z-R81(K) E3Z-R86 E3Z-D81(K) E3Z-D86 E3Z-D82(K) E3Z-D87	Light-ON	Incident light No incident light Operation indicator ON Operation indicator (orange) OFF Output transistor ON Output transistor OFF Load Operate (e.g., relay) Reset (Between blue and black leads)	L side (LIGHT ON)	Through-beam Receivers, Retro-reflective Models, Diffuse-reflective Models.
	Dark-ON	Incident light No incident light Operation indicator ON Operation indicator (orange) OFF Output transistor ON Output transistor OFF Load Operate (e.g., relay) Reset (Between blue and black leads)	D side (DARK ON)	Connector Pin Arrangement Pin 2 is not used.
Through-beam Emitter				

Plugs (Sensor I/O Connectors)

Classification	Wire color	Connector pin No.	Application
DC	Brown	1	Power supply (+V)
	White	2	—
	Blue	3	Power supply (0 V)
	Black	4	Output

Note: Pin 2 is not used.

Wire color: Brown (orange), White, Blue, Black

XS3F-M421-402-A
XS3F-M421-405-A
XS3F-M422-402-A
XS3F-M422-405-A

Nomenclature

Through-beam Models

E3Z-T□□ (Emitter)

E3Z-T□□A (Receiver)

Diffuse-reflective Models

E3Z-D□□

Retro-reflective Models

E3Z-R□□

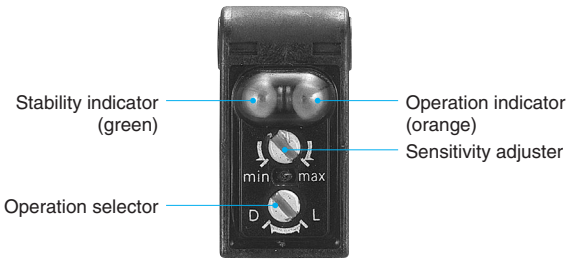

Procedure for Adjusting Cable Length (Clamp-type e-CON Pre-wired Connector)

Wire Removal Procedure

1. Use a flat-blade precision screwdriver to push the operating lever in and lock it in place. Pull out the wires.
2. Rewire immediately. If rewiring will not be performed for longer than 8 hours, be sure to release the operating lever. (See step 3 of the Wiring Procedure below.)

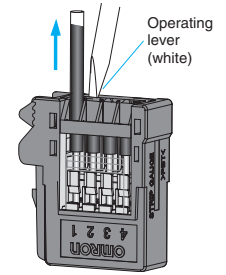

Cable Length Adjustment Procedure

Cut the cable to the desired length. Place the cable wire on the strip gauge located on the side of the E3Z to determine the length of exposed wire. Strip 7 to 8 mm of the covering from the wire. If the cable is stranded, give the wire several twists.

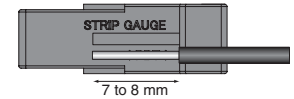

Wiring Procedure

1. Use the flat-blade precision screwdriver to check and see if the lever is locked down in the operating slot.
2. Insert the wires into the wire slots as far as they will go. Make sure the tip of the conductors have passed all the way through the terminal block.

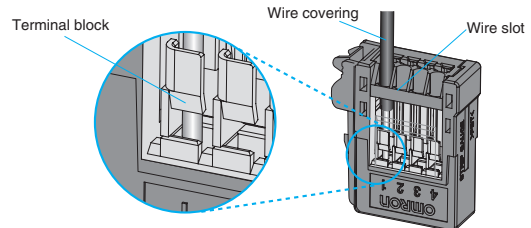
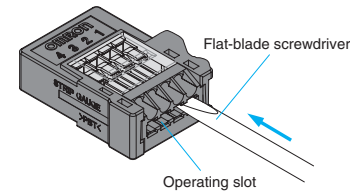

3. Insert the screwdriver into the release slot. Push up lightly until you hear the operating lever snap back into place.

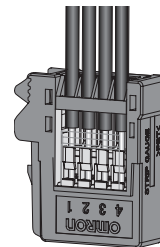
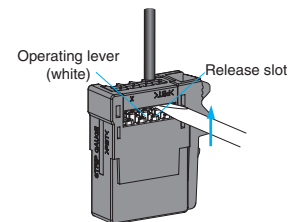

4. Perform the following items.
 - Check to see if the operating lever is back in its initial position.
 - Repeat step 2 of the Wiring Procedure above. (The wiring is correct if there is resistance when each wire is lightly pulled.)

Photo-electric Sensors

Sensing Guide

Optical Fibers

Separate Amplifiers

Built-in Amplifiers

Built-in Power Supplies

Application Specific

Peripheral Devices

Other Information

E3Z

E3Z-LS

E3Z-L

E3Z-B

E3Z-G

E3T

E3S-C

E3S-CL

E3G

E3Z

Safety Precautions

Refer to *Warranty and Limitations of Liability* on page F-2.

⚠ WARNING

This product is not designed or rated for ensuring safety of persons. Do not use it for such purpose.



Precautions for Correct Use

● Wiring

M8 Metal Connector

- Be sure to connect or disconnect the metal connector after turning OFF the Sensor.
- Hold the connector cover to connect or disconnect the metal connector.
- Secure the connector cover by hand. Do not use any pliers, otherwise the connector may be damaged.
- The proper tightening torque range is between 0.3 and 0.4 N·m. Be sure to tighten the connector securely, otherwise the specified degree of protection may not be maintained or the connector may be disconnected due to vibration.

● Mounting

Sensor Mounting

Use M3 screws to mount the sensor and tighten each screw to a maximum torque of 0.53 N·m.

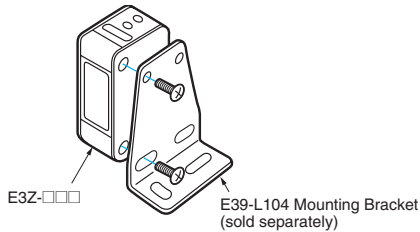

● Oil-resistant Models

Oil Resistance

- Although the E3Z-□□□K Sensors have oil-resistant specifications, performance may be affected by certain types of oil. Refer to the following table.
- E3Z-□□□K Sensors are tested for resistance to the oils given in the following table. Refer to the information in the table when deciding which type of oil to use.

Test oil classification	JIS classification	Product name	Kinematic viscosity (mm ² /s) at 40°C	pH
Lubricant	---	Velocity No.3	2.02	
Water insoluble machining oil	Class 2, No. 5	Daphne Cut AS-30D	No less than 10 to no less than 50	---
	Class 2, No. 11	Yushiron Oil No.2 ac	Less than 10	
Water soluble machining oil	Class W1, No.1	Yushiroken EC50T-3	---	7 to 9.5
		Yushiron Lubic HWC68		7 to 9.9
	Class W1, No.2	Gryton 1700D		7 to 9.2
	Class W2, No.1	Yushironken S50N		7 to 9.8

Note: 1. The E3Z maintained a minimum insulation resistance of 100 MΩ after it was dipped in all the above oils for 240 hours.

2. When using the Sensors in environments subject to oils other than those listed above, use the figures for kinematic viscosity and pH from the table as general guidelines. Additives and other substances contained in oils may affect the E3Z. Be sure to consider this before use.

E3Z

E3Z-LS

E3Z-L

E3Z-B

E3Z-G

E3T

E3S-C

E3S-CL

E3G

Dimensions

Sensors

Through-beam Pre-wired Models

E3Z-T61(K)
E3Z-T81(K)
E3Z-T61A
E3Z-T81A

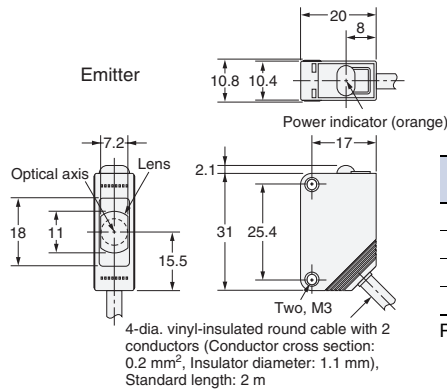

CAD data

Terminal No.	Specifications
1	+V
2	--
3	0V
4	--

Pins 2 and 4 are not used.

Press-fit e-CON Pre-wired Connector

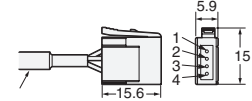

*4-dia. vinyl-insulated round cable with 2 or 3 conductors, Standard length: 2 m

Clamp-type e-CON Pre-wired Connector (E3Z-T61-ECON-C)

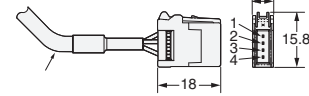

*4-dia. vinyl-insulated round cable with 2 or 3 conductors, Standard lengths: 0.3 m, 0.5 m, and 2 m

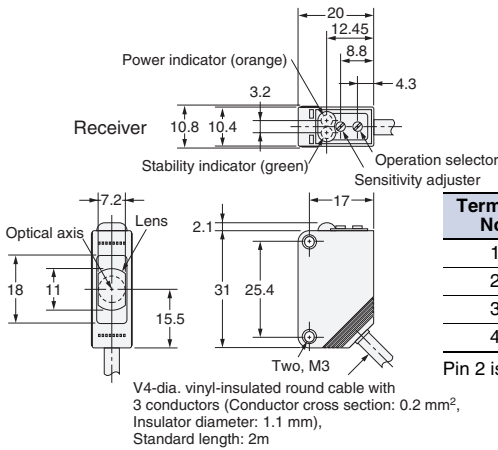

CAD data

Terminal No.	Specifications
1	+V
2	--
3	0V
4	Output

Pin 2 is not used.

M12 Pre-wired Connector (E3Z-T□□-M1J)

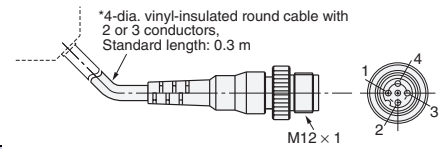

M8 Pre-wired Connector (E3Z-T□□K-M3J)

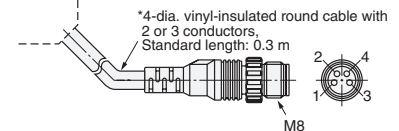

* The Emitter cable has two conductors and the Receiver cable has three conductors.

Through-beam Standard Connector Models

E3Z-T66
E3Z-T86
E3Z-T66A
E3Z-T86A

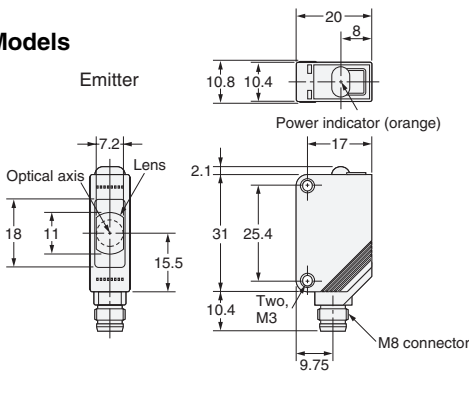

CAD data

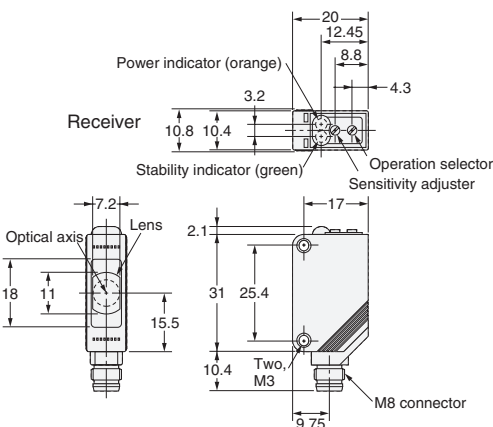

CAD data

Photo-electric Sensors

Sensing Guide

Optical Fibers

Separate Amplifiers

Built-in Amplifiers

Built-in Power Supplies

Application Specific

Peripheral Devices

Other Information

E3Z

E3Z-LS

E3Z-L

E3Z-B

E3Z-G

E3T

E3S-C

E3S-CL

E3G

Retro-reflective Models

Pre-wired Models

E3Z-R61(K)

E3Z-R81(K)



CAD data

Terminal No.	Specifications
1	+V
2	---
3	0V
4	Output

Diffuse-reflective Models

Pre-wired Models

E3Z-D61(K)

E3Z-D81(K)

E3Z-D62(K)

E3Z-D82(K)

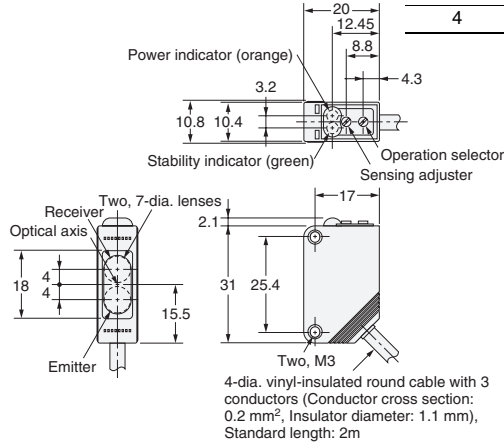

Press-fit e-CON Pre-wired Connector

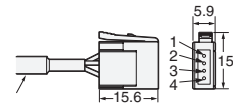

*4-dia. vinyl-insulated round cable with 3 conductors, Standard length: 2 m

Clamp-type e-CON Pre-wired Connector (E3Z-□□-ECON-C)

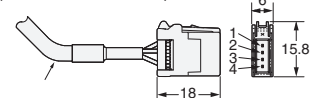

*4-dia. vinyl-insulated round cable with 3 conductors, Standard lengths: 0.3 m, 0.5 m, and 2 m

M12 Pre-wired Connector (E3Z-□□□-M1J)

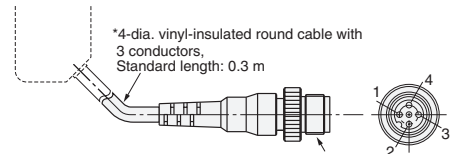

M8 Pre-wired Connector (E3Z-T□□-M3J)

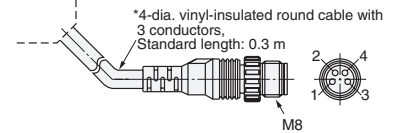

Retro-reflective Models

Standard Connector

Models

E3Z-R66

E3Z-R86



CAD data

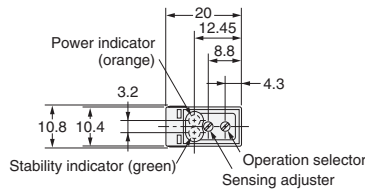

Diffuse-reflective Models

Standard Connector

Models

E3Z-D66

E3Z-D86

E3Z-D67

E3Z-D87

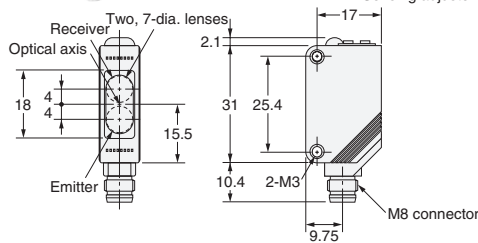

E3Z

E3Z-LS

E3Z-L

E3Z-B

E3Z-G

E3T

E3S-C

E3S-CL

E3G

e-CON Connector Configurations

Wiring method	Sensor connectors
Press-fit	37104-3122-000FL (made by Sumitomo 3M)
Clamp	XN2A-1430 (made by OMRON)

Accessories (Order Separately)

Slits

E39-S65A
E39-S65B
E39-S65C

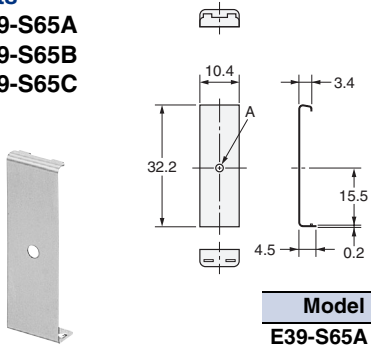

Model	Size A	Material
E39-S65A	0.5 dia.	SUS301 stainless steel
E39-S65B	1.0 dia.	
E39-S65C	2.0 dia.	

Slits

E39-S65D
E39-S65E
E39-S65F

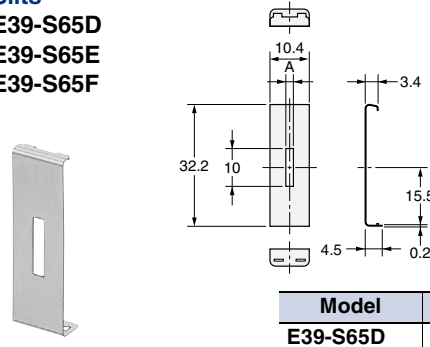

Model	Size A	Material
E39-S65D	0.5	SUS301 stainless steel
E39-S65E	1.0	
E39-S65F	2.0	

Reflectors

Refer to page 295 for details.

Mounting Brackets

Refer to 292 for details.

Photo-electric Sensors

Sensing Guide

Optical Fibers

Separate Amplifiers

Built-in Amplifiers

Built-in Power Supplies

Application Specific

Peripheral Devices

Other Information

E3Z

E3Z-LS

E3Z-L

E3Z-B

E3Z-G

E3T

E3S-C

E3S-CL

E3G