



**5 Year  
Warranty**

# H8100 Series

## Commercial Energy Consumption Meters

The **H8100 Series Energy Meters** are easy to install, provide exceptional system accuracy, making them ideal for all submetering applications.

Installing an Energy Meter is simple: just mount the meter, connect the neutral, and the three, colored voltage leads to the power conductors of the electrical service, and match the CTs (e.g., red voltage lead and red CT must be on the same conductor) to the voltage leads. Since the meter automatically detects and compensates for phase reversal, the concern of CT load orientation is eliminated and installation time is greatly reduced.

To provide excellent total system accuracies of 1% from 2% to 100% of the rating of the CTs (e.g., 2-100 amps with 100 amp CTs), each meter is factory matched with quick to install split-core CTs. The meter/CTs are system calibrated.

### APPLICATIONS

- Commercial tenant submetering
- Performance contracting
- Cost allocation
- Real-time power monitoring via local display or through control/data acquisition systems

### The ultimate stand-alone energy metering system

- High resolution backlit LCD display provides clear readings at a distance and under any lighting conditions...reduces the risk of misinterpretation of the data. Back lighting can be disabled if desired

### Easy integration to control or data acquisition systems

- H8163 provides a pulse output from 1/10 to 1 pulse per kWh provides easy connection to existing control systems
- H8163 provides a phase loss alarm...protects equipment
- With the optional Communications Board (H8163-CB) Energy Meters (H8150 & H8163) can easily be added to a Modbus® control systems network to report multiple variables including kW, kWh, kVAR, PF, Amps and Volts, providing crucial power information at a reduced installation cost

### Simple, fast installation

- Split-core CTs eliminate the need to remove electrical conductors, greatly reducing installation time
- Energy Meters automatically detect and correct phase reversal, eliminating the need to be concerned with CT load orientation
- CTs and voltage leads are color coded making it easy to determine correct connection

### ORDERING INFORMATION

#### 120VAC-240VAC

AMPS	ONE CT	TWO CTs	THREE CTs	VOLTAGE	OUTPUT
100 Micro	H8150-0100-0-1	H8150-0100-0-2	H8150-0100-0-3	120-240VAC	Display Only
200 Mini	H8150-0200-1-1	H8150-0200-1-2	H8150-0200-1-3	120-240VAC	Display Only
300 Small	H8150-0300-2-1	H8150-0300-2-2	H8150-0300-2-3	120-240VAC	Display Only
400 Med		H8150-0400-3-2	H8150-0400-3-3	120-240VAC	Display Only
800 Med		H8150-0800-3-2	H8150-0800-3-3	120-240VAC	Display Only
800 Lg			H8150-0800-4-3	120-240VAC	Display Only
1600 Lg			H8150-01600-4-3	120-240VAC	Display Only
2400 Lg			H8150-2400-4-3	120-240VAC	Display Only

#### 120VAC-480VAC

AMPS	ONE CT	TWO CTs	THREE CTs	VOLTAGE	OUTPUT
100 Micro	H8163-0100-0-1	H8163-0100-0-2	H8163-0100-0-3	120-480VAC	Std P & Ph L*
200 Mini	H8163-0200-1-1	H8163-0200-1-2	H8163-0200-1-3	120-480VAC	Std P & Ph L*
300 Small	H8163-0300-2-1	H8163-0300-2-2	H8163-0300-2-3	120-480VAC	Std P & Ph L*
400 Med		H8163-0400-3-2	H8163-0400-3-3	120-480VAC	Std P & Ph L*
800 Med		H8163-0800-3-2	H8163-0800-3-3	120-480VAC	Std P & Ph L*
800 Lg			H8163-0800-4-3	120-480VAC	Std P & Ph L*
1600 Lg			H8163-01600-4-3	120-480VAC	Std P & Ph L*
2400 Lg			H8163-2400-4-3	120-480VAC	Std P & Ph L*

\*Standard Pulse and Phase Loss Output

### ACCESSORIES

Fuse and Fuseholders, see page 234



**APPLICATIONS/WIRING EXAMPLES:**

208/120VAC, 4-wire, 3Ø, 200 Amp Service

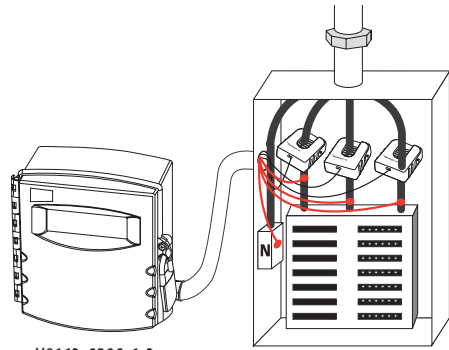

H8163-0200-1-3

240VAC, 3-wire, Single Phase, 100 Amp Service

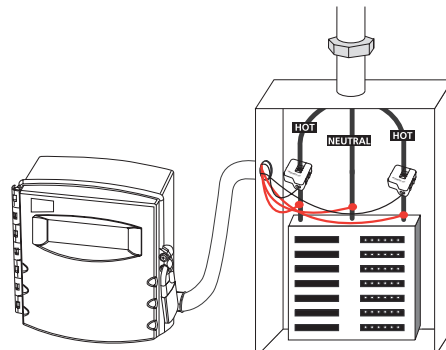

H8163-0100-0-2

120VAC, 2-wire, Single Phase, 100 Amp Service

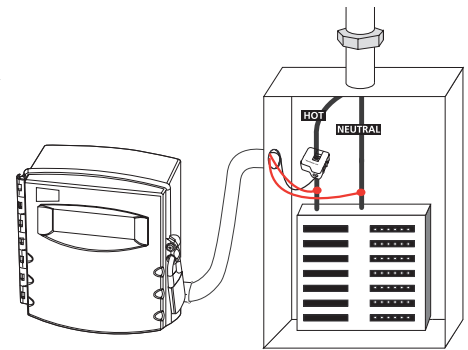

H8163-0100-0-1

**DIMENSIONAL DRAWINGS**

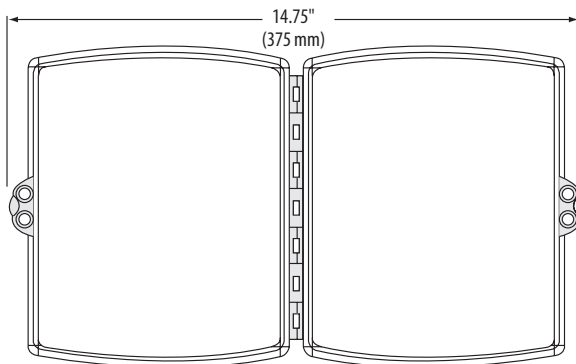
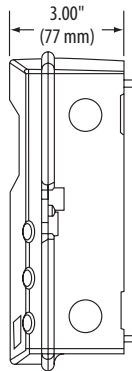
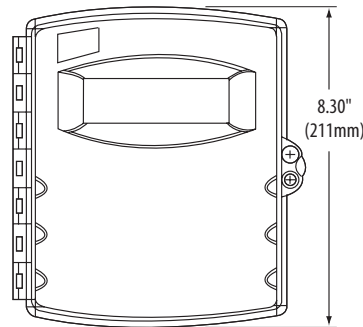
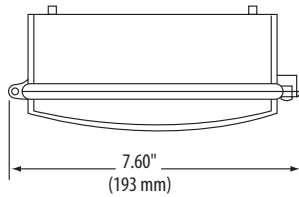

**MICRO\***  
**100 Amp**

- A = 2.15" (55 mm)
- B = 1.28" (33 mm)
- C = 0.518" (13 mm)
- D = 0.915" (24 mm)
- E = 2.34" (60 mm)
- F = 3.52" (90 mm)

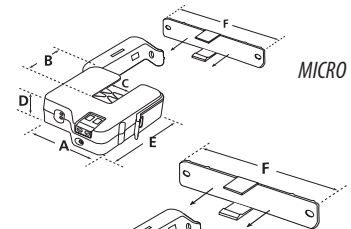

**MINI\***  
**200 Amp**

- A = 2.58" (66 mm)
- B = 1.10" (28 mm)
- C = 0.75" (19 mm)
- D = 1.04" (27 mm)
- E = 2.90" (74 mm)
- F = 3.52" (90 mm)

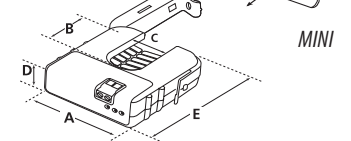

**SMALL**  
**300 Amp**

- A = 3.75" (95 mm)
- B = 1.51" (38 mm)
- C = 1.25" (32 mm)
- D = 1.13" (29 mm)
- E = 4.20" (107 mm)
- F = 4.75" (121 mm)

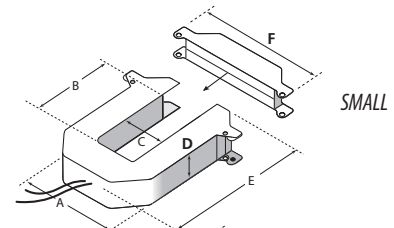

**MEDIUM**  
**400/800 Amp**

- A = 4.90" (124 mm)
- B = 2.89" (73 mm)
- C = 2.45" (62 mm)
- D = 1.13" (29 mm)
- E = 5.57" (141 mm)
- F = 5.92" (150 mm)

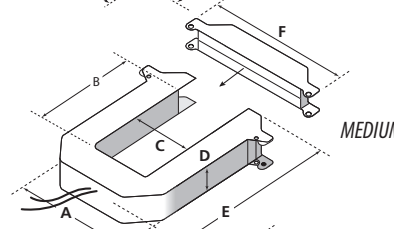

**LARGE**  
**800/1600/2400 Amp**

- A = 4.90" (124 mm)
- B = 5.50" (140 mm)
- C = 2.45" (62 mm)
- D = 1.13" (29 mm)
- E = 8.13" (207 mm)
- F = 5.92" (150 mm)

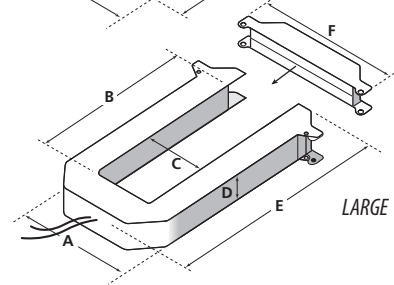



### DATA OUTPUT (requires H8163-CB Communication Board)

kWh, Consumption  
 kW, Real power  
 kVAR, Reactive power  
 kVA, Apparent power  
 Power factor  
 Voltage, line to line  
 Voltage, line to neutral  
 Amps, Average current  
 kW, Real Power ØA  
 kW, Real Power ØB  
 kW, Real Power ØC  
 Power factor ØA  
 Power factor ØB  
 Power factor ØC  
 Voltage, ØA to ØB  
 Voltage, ØB to ØC  
 Voltage, ØA to ØC  
 Voltage, ØA to Neutral  
 Voltage, ØB to Neutral  
 Voltage, ØC to Neutral  
 Amps, Current ØA  
 Amps, Current ØB  
 Amps, Current ØC

\*not supported at >1600A

\*\*not supported at >2400A

†Do not apply 600V Class current transformers to circuits having a phase-to-phase voltage greater than 600V, unless adequate additional insulation is applied between the primary conductor and the current transformers. Veris assumes no responsibility for damage of equipment or personal injury caused by products operated on circuits above their published ratings.

### GENERAL SPECIFICATIONS

<b>LCD Display</b>	1.2" (31mm) x 3.8" (97mm) viewing area, 160 segments, back-lit with green LEDs
<b>Insulation Class</b>	600VAC†
<b>Sample Rate</b>	1280Hz.
<b>Internal Isolation</b>	2500VAC
<b>Operating Temp. Range</b>	0 to 50°C (<95%RH, non-condensing)
<b>Storage Temp. Range</b>	-40°C to 70°C
<b>Systems Accuracy</b>	±1% of reading from 2% to 100% of the rated current of the CTs... accomplished by matching the CTs with a meter and calibrating them as a system
<b>Power Consumption</b>	50VA
<b>Voltage Tolerance:</b>	
<b>H8150</b>	90 - 132VAC line-to-neutral
<b>H8163</b>	90 - 300VAC line-to-neutral
<b>Electrical Services:</b>	
<b>H8150</b>	120/240 VAC with neutral, 208Y/120 VAC line to neutral
<b>H8163</b>	Any service where the phase A-N voltage is ≤300VAC and the phase-to-phase voltage is ≤480VAC nominal with neutral
<b>Frequency</b>	50/60Hz.
<b>Pulse Output (H8163 only)</b>	N.O., Opto-FET, 100mA @ 24VAC/DC
<b>Pulse Rate (H8163 only)</b>	0.10*, 0.25**, 0.50, or 1.00 kWh per pulse
<b>Pulse Width (H8163 only)</b>	200msec closed
<b>Phase Loss Alarm Output (H8163 only)</b>	N.C., Opto-FET, 100mA @ 24VAC/DC. Fixed threshold 25% below any other phase. Always open as long as alarm persists
<b>Protection Class</b>	NEMA 1

