

Installation Instructions

Hawkeye 8100 Series

ENERGY METER



VERIS INDUSTRIES

PORTLAND, OREGON USA
(503) 598-4564 FAX (503) 598-4664
1-800-354-8556

<http://www.veris.com> email: sales@veris.com



OPERATION

Applications

- Tenant submetering
- Performance contracting
- Cost allocation
- Real time power monitoring via local display or control/data acquisition system

Fast Trouble-free Installation

- Split-core CTs eliminate the need to remove electrical conductors
- Meter automatically detects phase reversal - eliminates concerns about CT orientation
- CTs and voltage leads are color coded making it easy to determine matching
- Safe low voltage output CTs eliminate the need for shorting bars

Exceptional Systems Accuracy

- $\pm 1\%$ total system accuracy of 1% from 2% to 100% of the rating of the CTs
- True RMS measurement

FCC PART 15 INFORMATION

NOTE: This equipment has been tested by the manufacturer and found to comply with the limits for a class A digital device, pursuant to part 15 of the FCC Rules. These limits are designed to provide reasonable protection against harmful interference when the equipment is operated in a commercial environment. This equipment generates, uses, and can radiate radio frequency energy and, if not installed and used in accordance with the instruction manual, may cause harmful interference to radio communications. Operation of this equipment in a residential area is likely to cause harmful interference in which case the user will be required to correct the interference at his own expense. Modifications to this product without the express authorization of Veris Industries nullify this statement.

The 8100 series Energy Meter combines highly accurate industrial grade split-core CT's and precision microprocessor based metering electronics in a single package to provide exceptional metering accuracy and to greatly reduce the total metering system installed cost. To provide excellent total system accuracies of 1% from 2% to 100% of the ratings of the CTs (e.g., 2-100 amps with 100 amp CTs), each meter is factory matched with quick to install split-core CTs. The meter/CTs are system calibrated.

The unique design and installer friendly features of the Energy Meter greatly reduce the time and overall cost of installing an energy metering system. The split-core CT's install very quickly and clamp directly to the electrical conductor, eliminating the need for mounting brackets. All models feature low voltage outputs so shorting blocks are unnecessary. CT load orientation concerns are eliminated because the meter automatically detects phase reversal.

The meter display provides valuable installation diagnostics. If the meter is installed and the CT's and voltage leads are not properly matched the display will provide the installer with human readable feedback as to what is wrong and how to correct the installation.

The H8150 Series Energy Meter provides an input voltage range of 120-240VAC, and an option of a communications board (Modbus RTU presently available)*. The H8160 Series Energy Meter provides an extended input voltage range (120-480 VAC, auto-ranging), a pulse output for easy integration with control systems, a phase loss output to help protect equipment, and the option of a communications board (Modbus RTU presently available)*.

When equipped with a communications board and connected to a Modbus control/data acquisition system, the Energy Meter can report 26 energy and power diagnostics variables, including, kWh, kW, PF, KVAR, Volts, and Amps.

**Other protocols available. Contact factory.*

PRODUCT DIAGRAM (see Figures 1&2)

- A** Large Digit Backlit Display for data and diagnostics
- B** Security Hasp
- C** CT Input Terminals ensure that voltage lead and CT are properly matched (e.g. red on red, see page 5)
- D** Voltage Input Terminals ensure that voltage lead and CT are properly matched (e.g. red on red, see page 5)
- E** Pulse Output Terminal provides easy integration to existing control/data acquisition systems. (see page 6) [H8160 Series only]
- F** Phase Loss Output Alarm Alarm trips if phase voltage drops 25% to protect valuable equipment. (see page 6) [H8160 Series only]
- G** Pulse Rate Selection Switch Set the pulse output at 0.1, 0.25, 0.50, or 1 pulse/kWh to match resolution requirements. (see page 7) [H8160 Series only]
- H** kWh Reset To reset the kWh counter, both buttons must be pushed at the same time (see page 8)
- I** Backlight Enable Jumper Remove this jumper to disable lighting (see page 6)
- J** Plain/Full Display Data Jumper (see page 7)

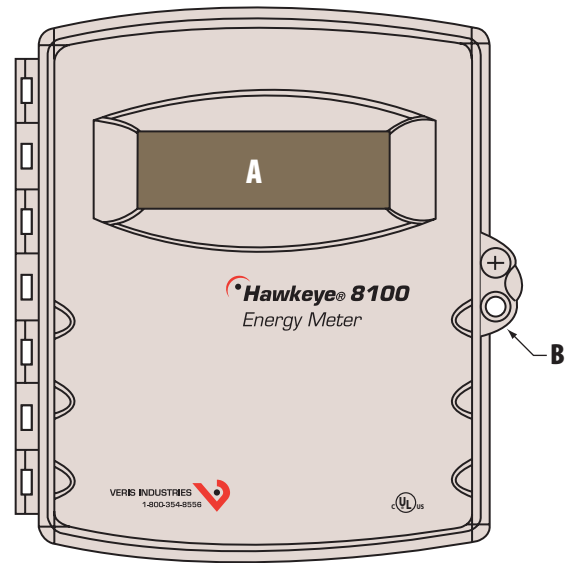

FIGURE 1

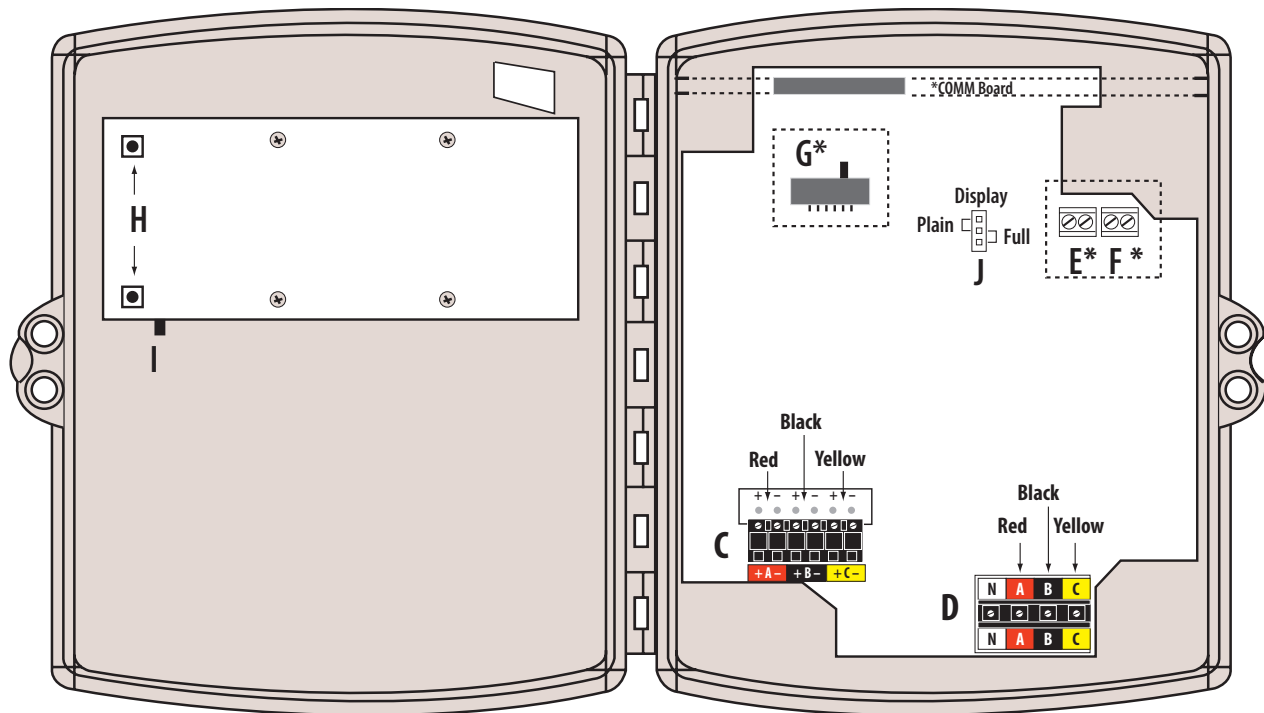

FIGURE 2

Color match CTs and voltage leads!

Example: Install the red label CT around the conductors that the red voltage lead is attached to.

**H8160 Series only.*

INSTALLATION INSTRUCTIONS

Installation should only be performed by qualified personnel who are familiar with applicable codes and regulations. The meter enclosure is designed FOR INDOOR USE ONLY. Install the Energy Meter within a maximum of 20' (5m) of the desired CT location. To prevent tampering, the meter should be secured with a padlock or other locking device. The meter and CTs are calibrated as a system. Prior to installation insure that the serial numbers match.

Meter Installation

1. Disconnect power and lockout all power sources during installation and configuration. **DO NOT CONNECT VOLTAGE INPUTS LIVE!**
2. If the connections to the meter will be made through more than one metallic conduit, the conduits will require bonding to prevent the hazard of electric shock. A bonding plate is available (P/N: AH11), or an equivalent means may be used.
3. Mount the meter box at an appropriate height allowing for direct vision as illustrated below.

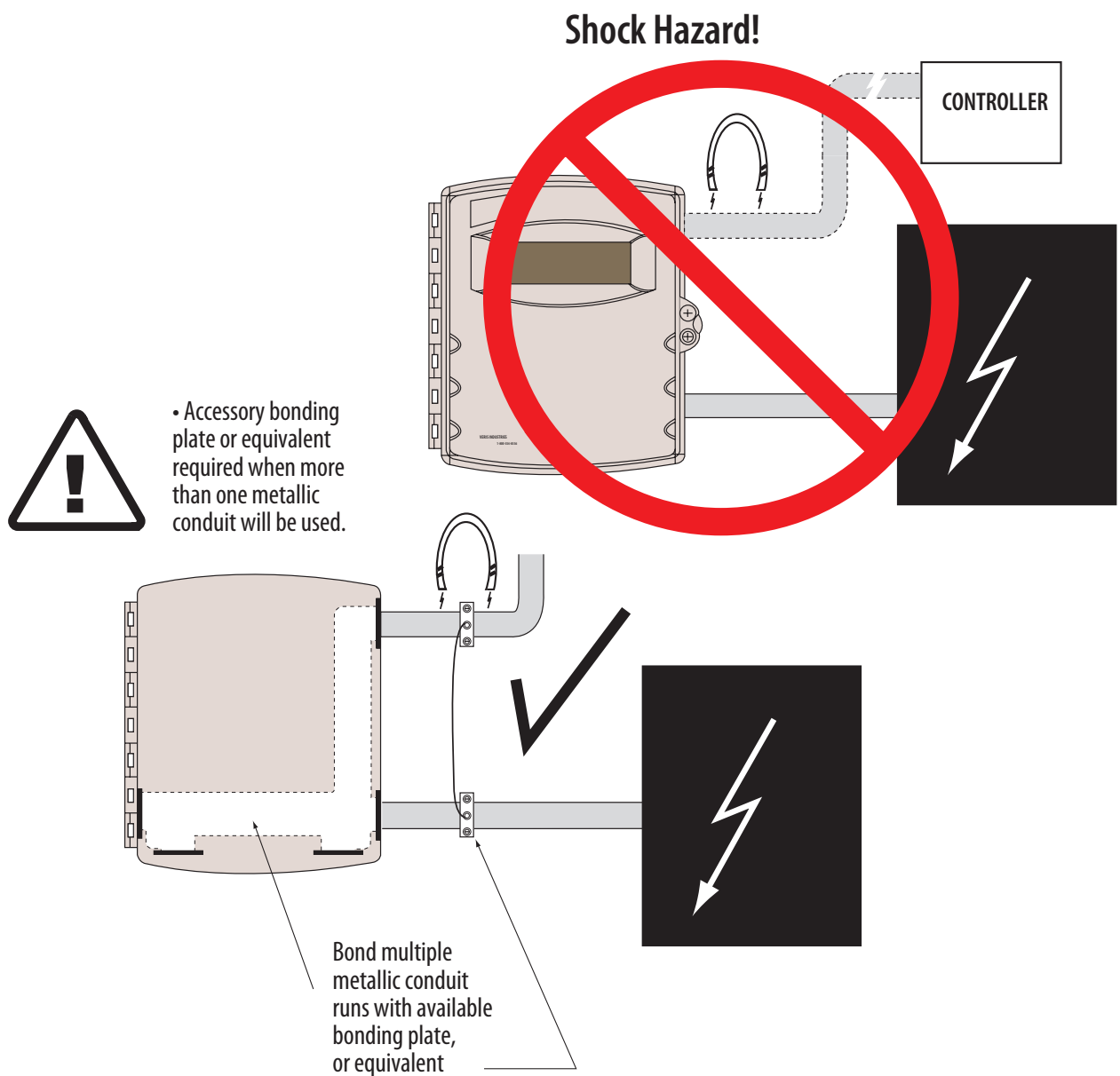

If using a hub on rigid conduit, assemble to conduit before attaching to meter.

INSTALLATION INSTRUCTIONS

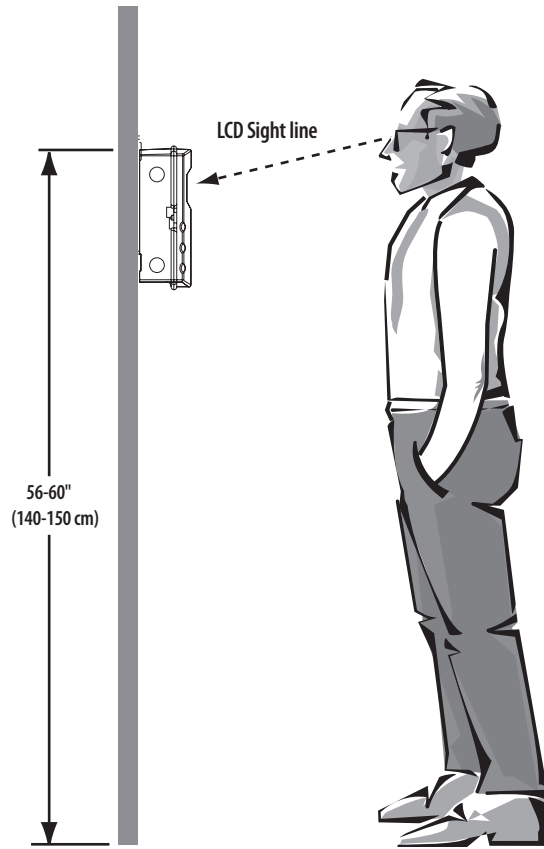

External fuses must be provided by installer, and may be purchased as an accessory, to comply with local and national codes. Fuse rating must be adequate to the applied voltage, with a current rating of 1/2 A (T) SLO-BLO. To comply with the requirements of the IEC and others, the fuse installation must be visible from the meter, or be provided with a lockout/tagout disconnect.



4. **Attach CT's to conductors.** The meter automatically detects phase reversal so it is not necessary to orient a particular side of each CT toward the load. A mounting

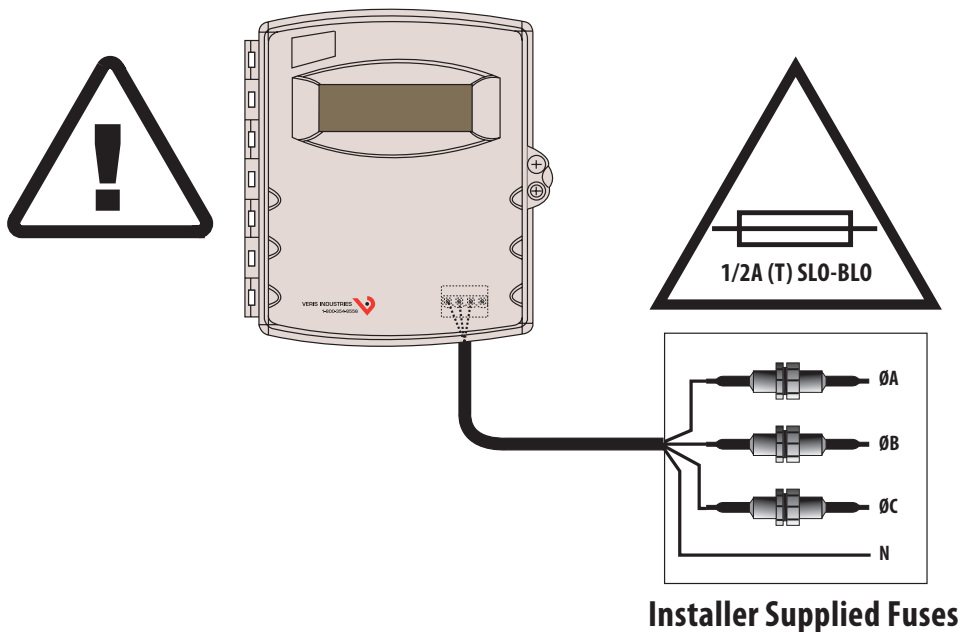

INSTALLATION INSTRUCTIONS

bracket may be desirable to meet local inspection requirements, and/or to maximize accuracy. Specified accuracy is achieved by passing the conductor through the geometric center of the CT window.

5. **Attach CT leads to appropriately colored CT input terminals** (e.g., red lead to red terminal) as shown. Polarity is indicated, with the minus (-) terminals connected to neutral within the meter, but polarity is insignificant to the operation of the meter.
6. **Connect voltage leads to phase conductors** as shown. Connect leads from the colored voltage terminals **to the power conductor with the matching CT** (e.g., red CT lead to red terminal). Since the meter is powered from the monitored source it is important that the voltage leads be connected to a circuit which is not normally switched off.

Connecting the Energy Consumption (Pulse) Output to Control/Data Acquisition Systems (DAQ) [H8160 Series only]

TYPICAL 208/480VAC, 4-WIRE, 3Ø INSTALLATION

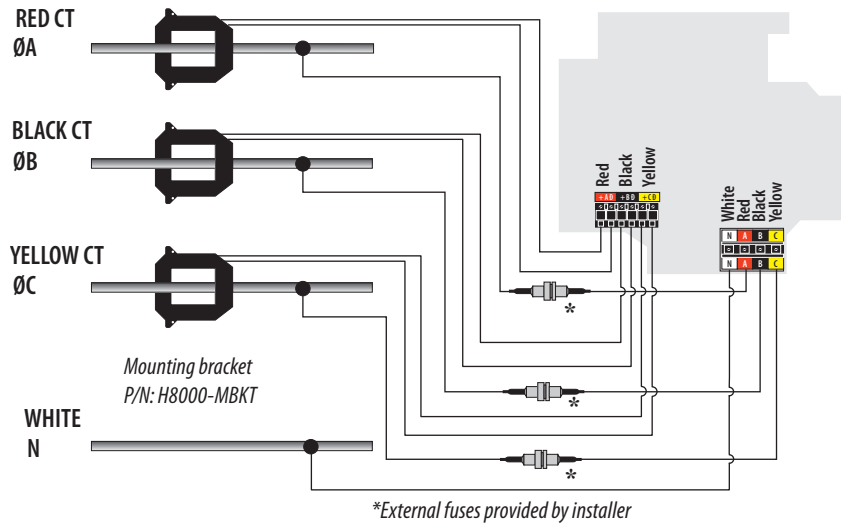

TYPICAL 240/120 VAC, 3-WIRE, 1Ø INSTALLATION

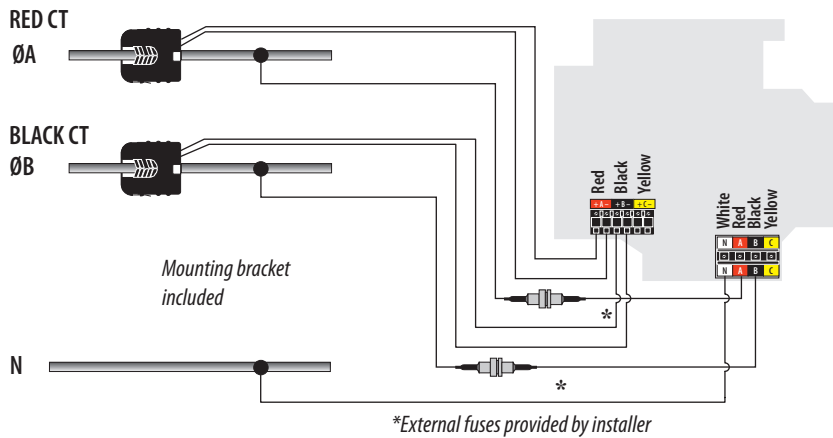

TYPICAL 120 VAC, 2-WIRE, 1Ø INSTALLATION

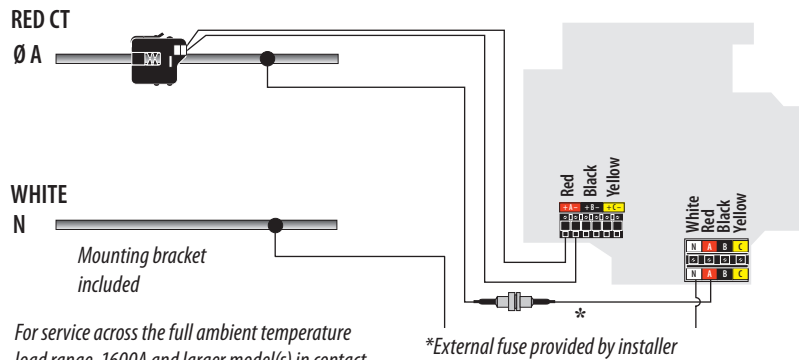

For service across the full ambient temperature load range, 1600A and larger model(s) in contact with a power conductor must be used with 90°C wire insulation, or be derated appropriately.

INSTALLATION INSTRUCTIONS

Wire the pulse output (pictured below) to the controller. Output is an electronic N.O. "contact closure" rated for 24V AC/DC @ 100mA maximum. Ensure that installation method and insulation ratings comply with local and national electrical codes.

Connecting the Phase Loss Output to Control/Data Acquisition Systems. [H8160 Series only]

Wire the phase loss output (pictured below) to the controller/DAQ system. Output is an electronic N.C. "contact closure" rated for 24V AC/DC @ 100mA. maximum. Ensure that installation method and insulation ratings comply with local and national electrical codes.

7. Set the Backlight Enable Jumper to the desired operating condition. Remove the jumper to disable the LCD backlight.

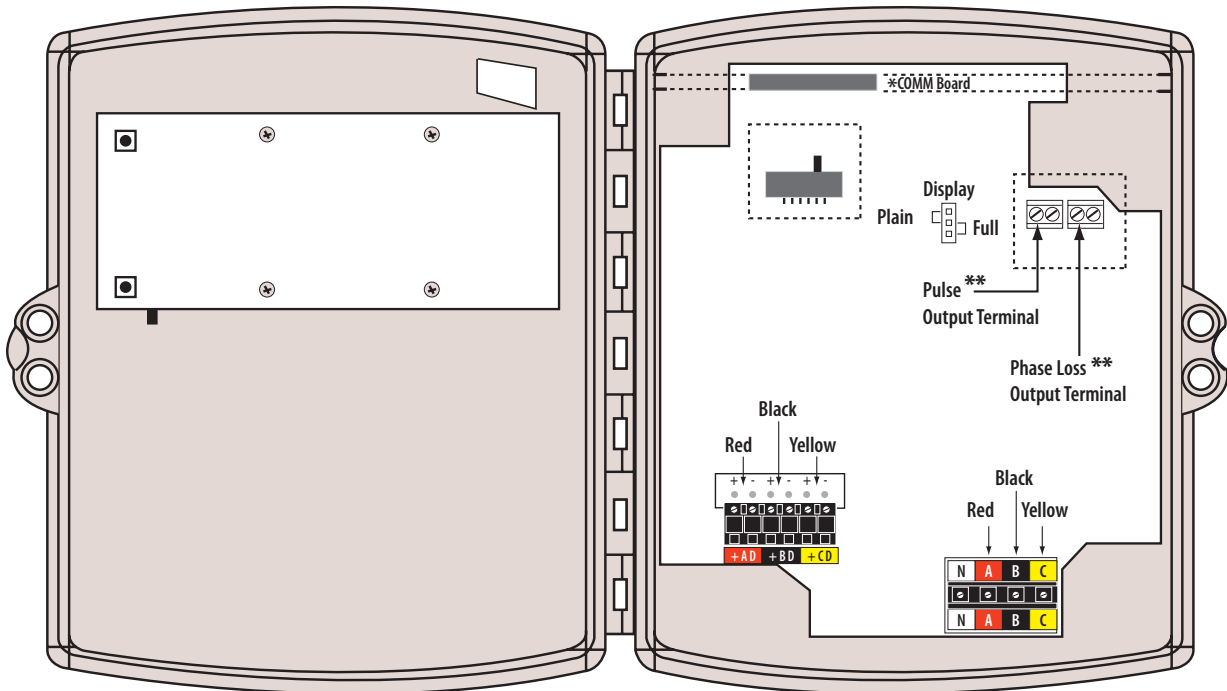
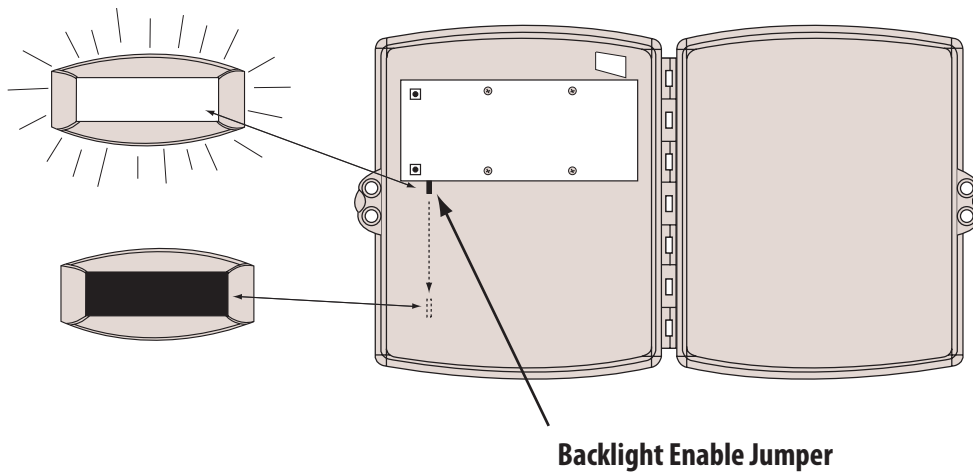

**COMM Board is Optional*

***H8160 Series only*

©2007 Veris Industries

INSTALLATION INSTRUCTIONS

- Set the **Display Data Jumper** to select between the "Plain" and "Full" settings. The "Plain" mode cycles the display through five data elements (KW, max KW since last reset, average power factor, line-to-line voltage, and amps) for four seconds each. The "Full" mode cycles through all of the data available in the meter (all the above, plus KVAR, data on individual phases, etc.) as described on following page.

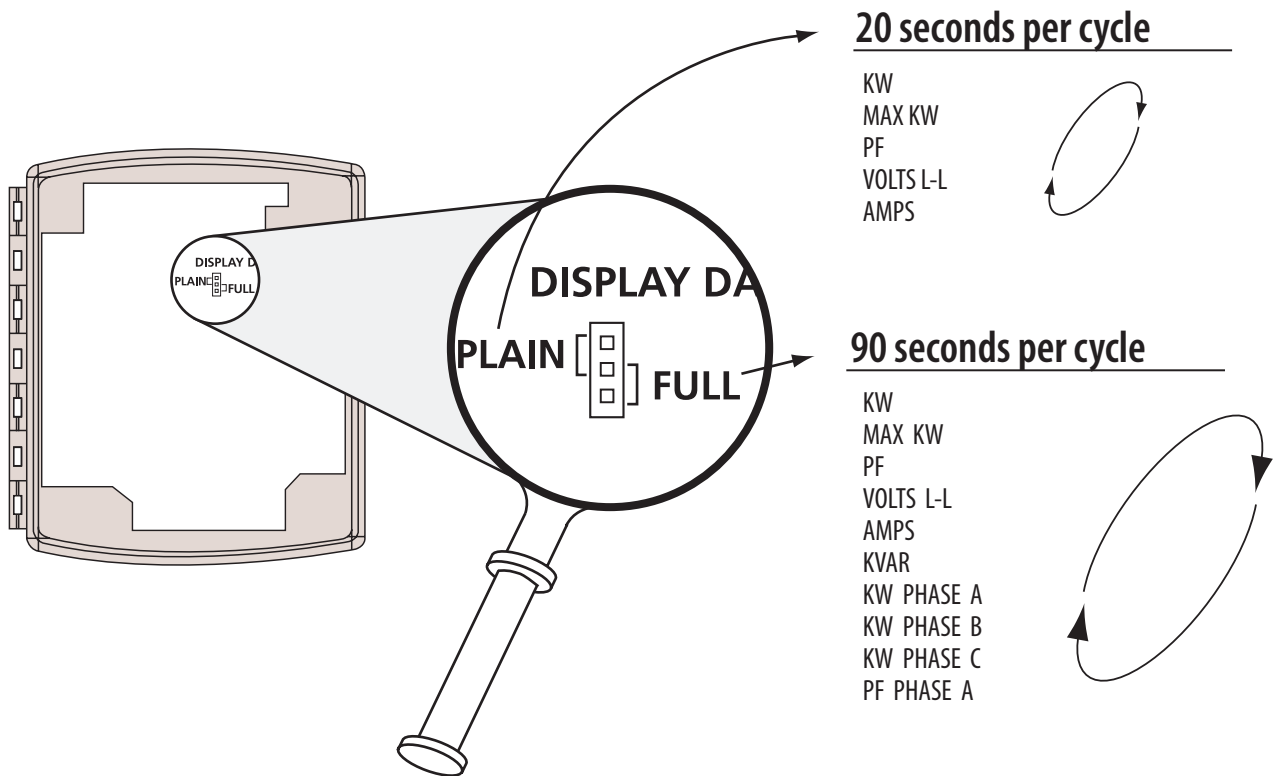

- Set **PULSE RATE Slide Switch [H8160 Series only]**: Set to desired output rate. Note that 0.1 is not valid for 1600A systems, and 0.1 and 0.25 are not available for 2400A systems.
- Apply power to the meter.**
- Check the meter display.** The meter checks each phase to ensure that the phasing is correct. If the phasing is correct the meter responds with OKAY, if the phasing of the CT and voltage leads are incorrect, the meter displays, ERROR CHECK WIRES RED* CT RED* VOLT LEAD SAME PHASE. *appropriate color
- Approximate check of power reading:

Check actual current with amp clamp. Expected power is:

$$\text{kW} = \text{Volts} \times \text{Amps} \times 1.732 \times \text{PF} / 1000$$

$$\text{kW} = \text{Horsepower} \times .746$$

INSTALLATION INSTRUCTIONS

Operation and Information Reporting

Power-Up

On power-up, the meter displays the firmware revision. It then checks each connection to ensure that the CT and voltage leads have been properly matched. A warning message will indicate each phase which has been found to be mismatched (note: the meter uses low Power Factor to determine improper phase matching).

Information Displayed When Meter is Running

The Energy Meter continually reports kilowatt hours (KWH) or megawatt hours (MWH), depending on the the total energy accumulated.

A secondary display cycles through other parameters. There are two modes of operation, depending on the setting of the DISPLAY DATA jumper (J8) on the main circuit board:

PLAIN: KW, MAX-KW, PF, VOLTS, AMPS

FULL: KW, PF, VOLTS, AMPS, KVAR, KW-A**, KW-B**, KW-C***, PF-A**, PF-B**,
PF-C***, VOLTS A-B***, VOLTS B-C***, VOLTS A-C***, VOLTS A-N**,
VOLTS B-N**, VOLTS C-N***, AMPS-A**, AMPS-B**, AMPS-C***

Every 10th rotation of parameters, the following parameters are also displayed:

PULSE-RATE****, ADDRESS*, BAUD-RATE*, PARITY*, 2/4WIRE*

*Only if Comms board installed

**2 and 3-CT meters only

***3-CT meters only

Alarms

The following alarm messages remain on the lower display as long as the alarm condition persists:

Phase Loss	If the voltage of any phase is measured as less than 75% of the voltage on any other phase, the display will show PHASE LOSS and indicate the problem phase(s).
Over Current	If the measured current is greater than 110% of the rated CT range, the display will show AMPS OVER and indicate the problem phase(s).
Over Voltage	Volts A-C, B-C or A-C is greater than 660VAC. If an error is detected, the display will show VOLTS OVER and indicate the problem phase(s).

Meter/Display Configuration

KWh Reset: Press and hold the two pushbuttons on the back of the LCD display board for about 10 seconds to zero the KWH accumulator.

KW Max. Reset: Press and hold the two pushbuttons on the back of the LCD display board for about 5 seconds to zero the KW max. register.

TROUBLESHOOTING

Problem	Check	Solution
No Display	Voltage at Voltage Terminals Is the input power to the meter switched?	Check External Fuses We recommend that the voltage connections be made to a point ahead of commonly operated switches, motor controllers, etc.
	Check Display cable	Assure that the ribbon cable from the main circuit board to the display has not been disconnected during installation.
	Check Wiring to product	Is A-N Voltage other than 100-300VAC correct voltage input.
	Check CT POWER terminals (holes on PC board)	Don't allow conductive materials (wire clippings, etc) to short between the holes in the main board near the CT Terminals, as these connect to the main power supply.
Too much, or too little display data	Display Data Jumper	Set jumper to correct position
No pulse output (H8163)	Supply voltage	The pulse output is a contact closure only – power must be supplied externally in the range of 5 – 24V AC/DC, with a maximum load of 100mA
	Signal Timing	The pulse output provides a contact closure for 200ms at each pulse time. Assure that the controller will accept this signal as an input.
Pulse output wrong, Display O.K (H8163)	Pulse Rate Switch	Set the pulse rate switch and controller to match. Pulse rate switch selects 0.1,0.25,0.5, or 1.0 kWh/Pulse Note that 0.1 is not valid for 1600A systems, and 0.1 and 0.25 are not available for 2400A systems.
Phase Loss output (H8163)	Always on	This output is normally closed (N.C.). Therefore it is closed at all times when the meter is correctly powered.
	No output	This output is a contact closure only and requires an external power supply in the range of 5-24V AC/DC, with a maximum load of 100mA
Reported power too low	CT match to voltage leads	The CT's must be mounted around the corresponding voltage lead's power conductor, e.g., the red CT must be mounted to the power conductor connected to the red voltage lead (the same is true for any other CT/voltage lead pairs). Check for phase loss Check fuses in voltage leads (field installed)
Reported power inaccurate	Check CT serial numbers	The CT's are calibrated to individual meters and must be connected to the meter they were calibrated with to assure optimum accuracy.
"bAd" appears on the display (H8163)	Pulse Rate Selection Switch	When an illegal pulse setting is selected, the kWh/PULSE segment is illuminated and "bAd" is shown on the lower display.
Accuracy not as specified	Check that CT serial numbers and meter serial numbers match.	Meter and CTs sold as set with accuracy calibrated as a set.

SPECIFICATIONS

GENERAL SPECIFICATIONS

LCD Display	1.2" x 3.8" viewing area, 160 segments, back lit with green LEDs
Insulation Class	600VAC†
Sample Rate	1280Hz.
Internal Isolation	2500VAC
Operating Temp. Range	0 to 50°C (<95%RH, non-condensing)
Storage Temp. Range	-40°C to 70°C
Systems Accuracy	±1% of reading from 2% to 100% of the rated current of the CTs...accomplished by matching the CTs with a meter and calibrating them as a system
Power Consumption	50VA
Voltage Tolerance	
H8150	(90 - 132VAC line-to-neutral)
H8163	(90-300VAC line-to-neutral)
Electrical Services	
H8150	120/240 VAC with neutral, 208Y/120 VAC line to neutral
H8163	Any service where the phase A-N voltage is ≤300VAC, and the phase-to-phase voltage is 480VAC nominal with neutral
Frequency	50/60Hz.
Pulse Output (H8163 only)	N.O., Opto-FET, 100mA @ 24VAC/DC
Pulse Rate (H8163 only)	0.10, 0.25, 0.50, or 1.00 kWh per pulse
Pulse Width (H8163 only)	200msec closed
Phase Loss Alarm Output (H8163 only)	N.C., Opto-FET, 100mA @ 24VAC/DC. Fixed threshold 25% below any other phase Always open as long as alarm persists
Safety	UL 3111-1 Cat. III pollution degree 2, alt. 0-2000 meters
Protection Class	NEMA 1

†Do not apply 600V Class current transformers to circuits having a phase-to-phase voltage greater than 600V, unless adequate additional insulation is applied between the primary conductor and the current transformers. Veris assumes no responsibility for damage of equipment or personal injury caused by products operated on circuits above their published ratings.

DATA OUTPUT (requires H8163-CB Communication Board)

kWh, Consumption
 kW, Real power
 kVAR, Reactive power
 kVA, Apparent power
 Power factor
 Voltage, line to line
 Voltage, line to neutral
 Amps, Average current
 kW, Real Power ØA
 kW, Real Power ØB
 kW, Real Power ØC
 Power factor ØA
 Power factor ØB
 Power factor ØC
 Voltage, ØA to ØB
 Voltage, ØB to ØC
 Voltage, ØA to ØC
 Voltage, ØA to Neutral
 Voltage, ØB to Neutral
 Voltage, ØC to Neutral
 Amps, Current ØA
 Amps, Current ØB
 Amps, Current ØC

COMMS BOARD OPTION

Modbus Communications

Output type.....Modbus RTU
 Connection2-wire or 4-wire selectable
 Baud rate2400, 4800, 9600, 19200 baud
 ParityNone/Odd/Even Selectable
 Address.....1-63
 Data Output.....refer to COMMS Board spec.

Inputs

Demand ResetStarts a new demand interval. Pulled-up to +5V via 4.7k.
 Contact closure or pull-to-ground. Edge-triggered

Installation Instructions

Hawkeye 8163

ENERGY METER



VERIS INDUSTRIES

PORTLAND, OREGON USA
(503) 598-4564 FAX (503) 598-4664
1-800-354-8556

<http://www.veris.com> email: sales@veris.com



OPERATION

The 8160 series energy meter combines highly accurate industrial grade split-core CT's and precision microprocessor based metering electronics in a single package to provide exceptional metering accuracy and to greatly reduce the total metering system installed cost. To provide excellent total system accuracies of 1% from 2% to 100% of the ratings of the CTs (e.g., 2-100 amps with 100 amp CTs), each meter is factory matched with quick to install split-core CTs. The meter/CTs are system calibrated.

The unique design and installer friendly features of the energy meter greatly reduce the time and overall cost of installing an energy metering system. The split-core CT's install very quickly and clamp directly to the electrical conductor, eliminating the need for mounting brackets. All models feature low voltage outputs so shorting blocks are unnecessary. CT load orientation concerns are eliminated because the meter automatically detects phase reversal.

The meter display provides valuable installation diagnostics. If the meter is installed and the CT's and voltage leads are not properly matched the display will provide the installer with human readable feedback as to what is wrong and how to correct the installation.

The energy meter provides an extended input voltage range (120-480 VAC, auto-ranging), a pulse output for easy integration with control systems, a phase loss output to help protect equipment, and the the option of a communications board (Modbus RTU presently available).

When equipped with a communications board and connected to a Modbus control/ data acquisition system, the energy meter can report 26 energy and power diagnostics variables, including, kWh, kW, PF, KVAR, Volts, and Amps.

Applications

- Tenant submetering
- Performance contracting
- Cost allocation
- Real time power monitoring via local display or control/data acquisition system

Fast Trouble-free Installation

- Split-core CTs eliminate the need to remove electrical conductors
- Meter automatically detects phase reversal - eliminates concerns about CT orientation
- CTs and voltage leads are color coded making it easy to determine matching
- Safe low voltage output CTs eliminate the need for shorting bars

Exceptional Systems Accuracy

- $\pm 1\%$ total system accuracy of 1% from 2% to 100% of the rating of the CTs
- True RMS measurement

FCC PART 15 INFORMATION

NOTE: This equipment has been tested by the manufacturer and found to comply with the limits for a class A digital device, pursuant to part 15 of the FCC Rules. These limits are designed to provide reasonable protection against harmful interference when the equipment is operated in a commercial environment. This equipment generates, uses, and can radiate radio frequency energy and, if not installed and used in accordance with the instruction manual, may cause harmful interference to radio communications. Operation of this equipment in a residential area is likely to cause harmful interference in which case the user will be required to correct the interference at his own expense. Modifications to this product without the express authorization of Veris Industries nullify this statement.

PRODUCT DIAGRAM (see Figures 1&2)

- A** IR Communications Port for easy download to Palm® Organizer
- B** Large Digit Backlit Display for data and diagnostics
- C** Security Hasp
- D** CT Input Terminals ensure that voltage lead and CT are properly matched (e.g. red on red, see page 5)
- E** Voltage Input Terminals ensure that voltage lead and CT are properly matched (e.g. red on red, see page 5)
- F** Pulse Output Terminal provides easy integration to existing control/data acquisition systems. (see page 6)
- G** Phase Loss Output Alarm Alarm trips if phase voltage drops 25% to protect valuable equipment. (see page 6)
- H** Pulse Rate Selection Switch Set the pulse output at 0.1, 0.25, 0.50, or 1 pulse/kWh to match resolution requirements. (see page 7)
- I** kWh Reset To reset the kWh counter, both buttons must be pushed at the same time (see page 8)
- J** Backlight Enable Jumper Remove this jumper to disable lighting (see page 6)
- K** Plain/Full Display Data Jumper (see page 7)

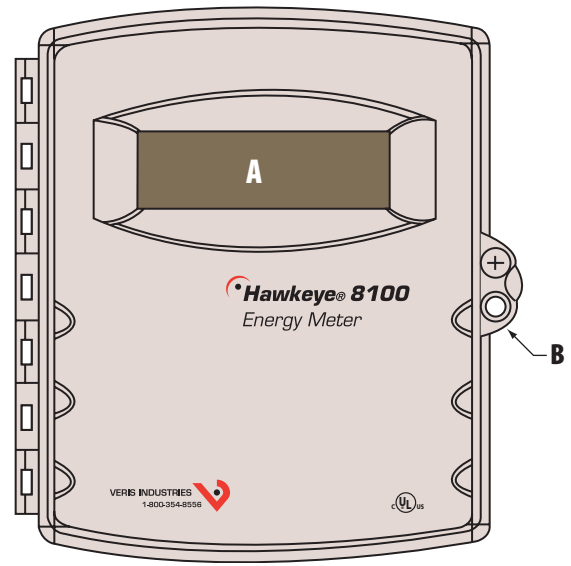

FIGURE 1

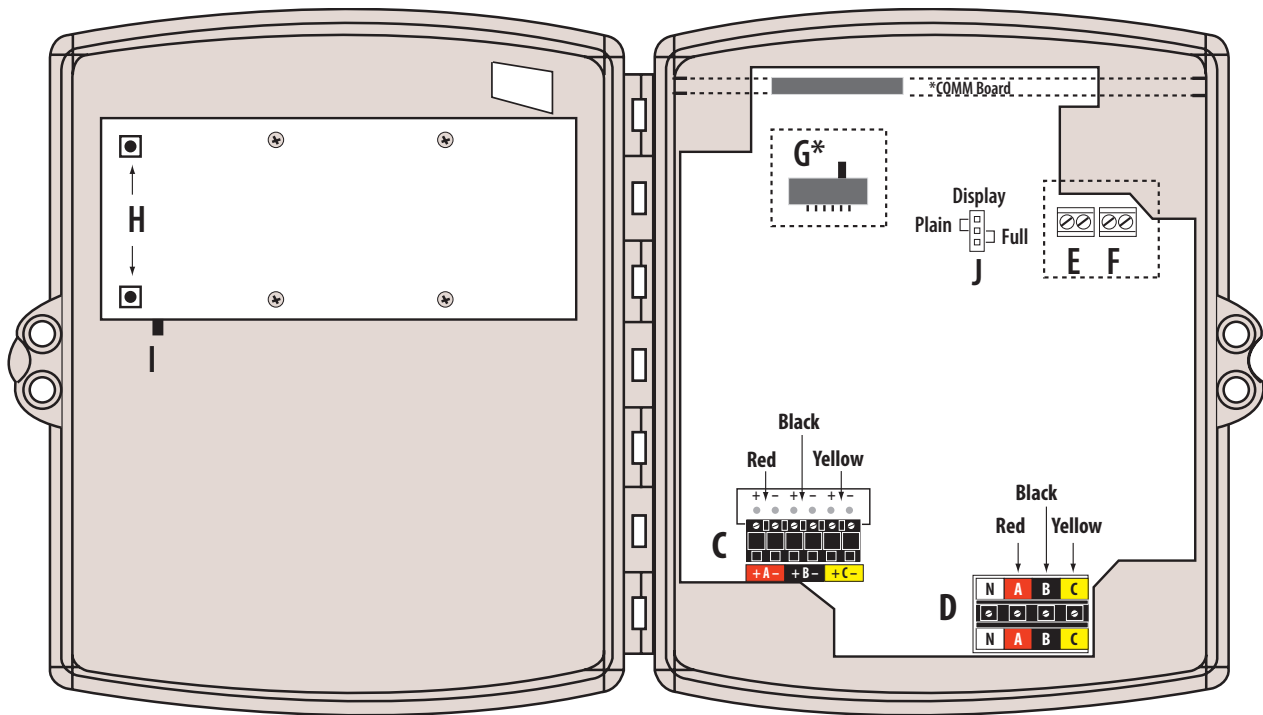

FIGURE 2

Color match CTs and voltage leads!

Example: Install the red label CT around the conductors that the red voltage lead is attached to.

INSTALLATION INSTRUCTIONS

Installation should only be performed by qualified personnel who are familiar with applicable codes and regulations. The meter enclosure is designed FOR INDOOR USE ONLY. Install the energy meter within a maximum of 20' (5m) of the desired CT location. To prevent tampering, the meter should be secured with a padlock or other locking device. The meter and CTs are calibrated as a system. Prior to installation insure that the serial numbers match.

Meter Installation

1. Disconnect power and lockout all power sources during installation and configuration. **DO NOT CONNECT VOLTAGE INPUTS LIVE!**
2. If the connections to the meter will be made through more than one metallic conduit, the conduits will require bonding to prevent the hazard of electric shock. A bonding plate is available (P/N: AH11), or an equivalent means may be used.
3. Mount the meter box at an appropriate height allowing for use with an organizer, or direct vision as illustrated below.

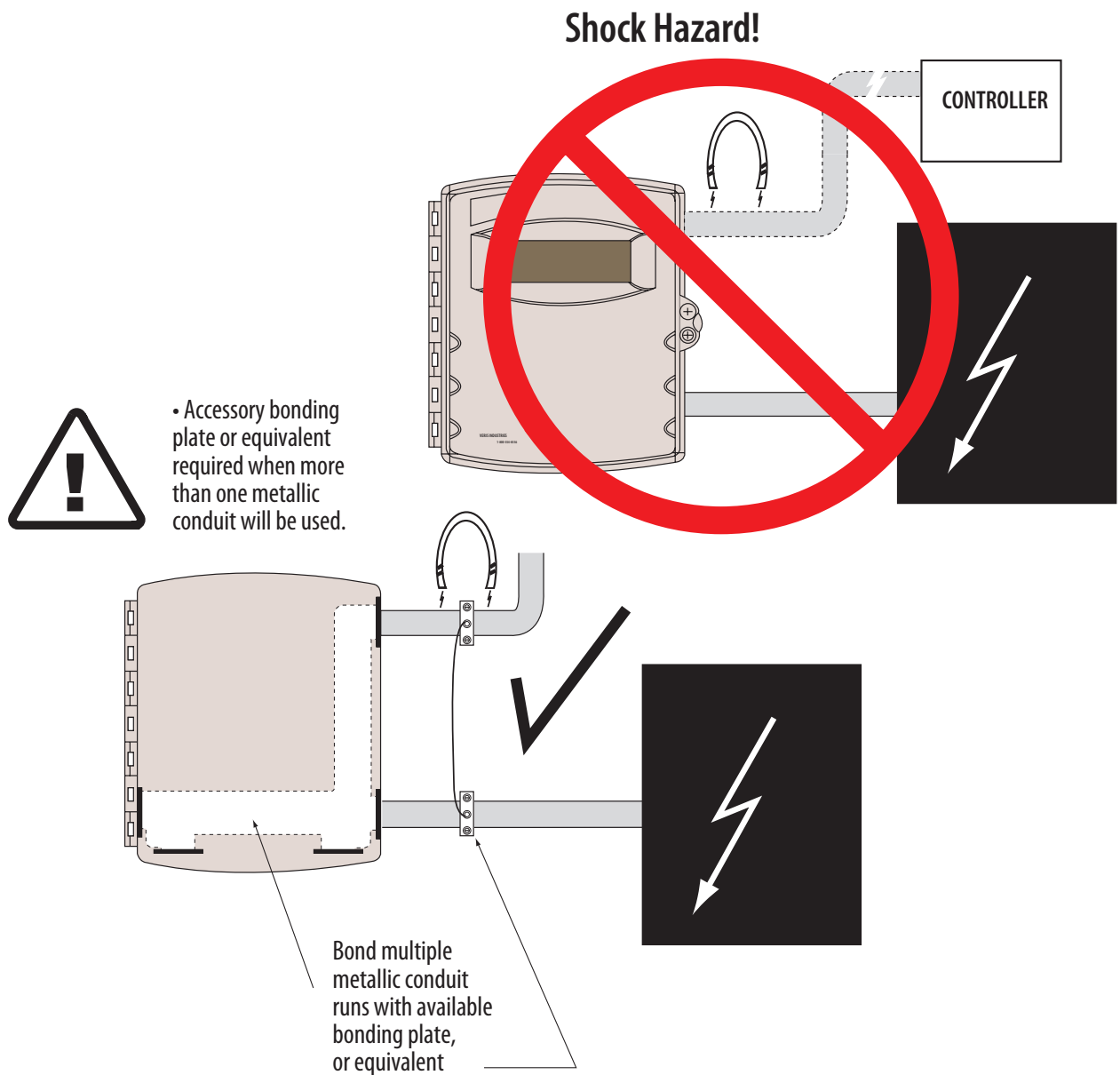

If using a hub on rigid conduit, assemble to conduit before attaching to meter.

INSTALLATION INSTRUCTIONS

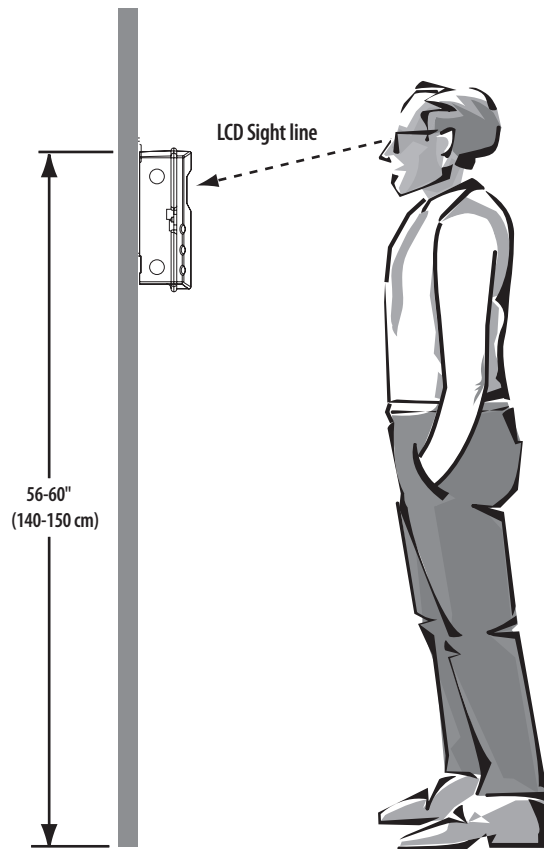

External fuses must be provided by installer, and may be purchased as an accessory, to comply with local and national codes. Fuse rating must be adequate to the applied voltage, with a current rating of 1/2 A (T) SLO-BLO. To comply with the requirements of the IEC and others, the fuse installation must be visible from the meter, or be provided with a lockout/tagout disconnect.



4. **Attach CT's to conductors.** The meter automatically detects phase reversal so it is not necessary to orient a particular side of each CT toward the load. A mounting

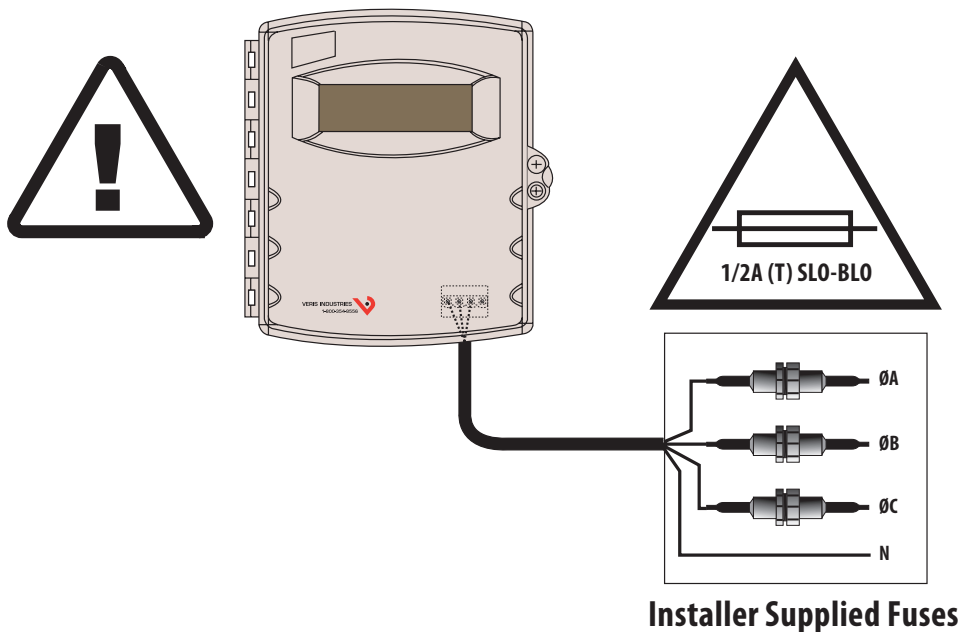

INSTALLATION INSTRUCTIONS

bracket may be desirable to meet local inspection requirements, and/or to maximize accuracy. Specified accuracy is achieved by passing the conductor through the geometric center of the CT window.

5. **Attach CT leads to appropriately colored CT input terminals** (e.g., red lead to red terminal) as shown. Polarity is indicated, with the minus (-) terminals connected to neutral within the meter, but polarity is insignificant to the operation of the meter.
6. **Connect voltage leads to phase conductors** as shown. Connect leads from the colored voltage terminals **to the power conductor with the matching CT** (e.g., red CT lead to red terminal). Since the meter is powered from the monitored source it is important that the voltage leads be connected to a circuit which is not normally switched off.

Connecting the Energy Consumption (Pulse) Output to Control/Data Acquisition Systems (DAQ)

TYPICAL 208/480VAC, 4-WIRE, 3Ø INSTALLATION

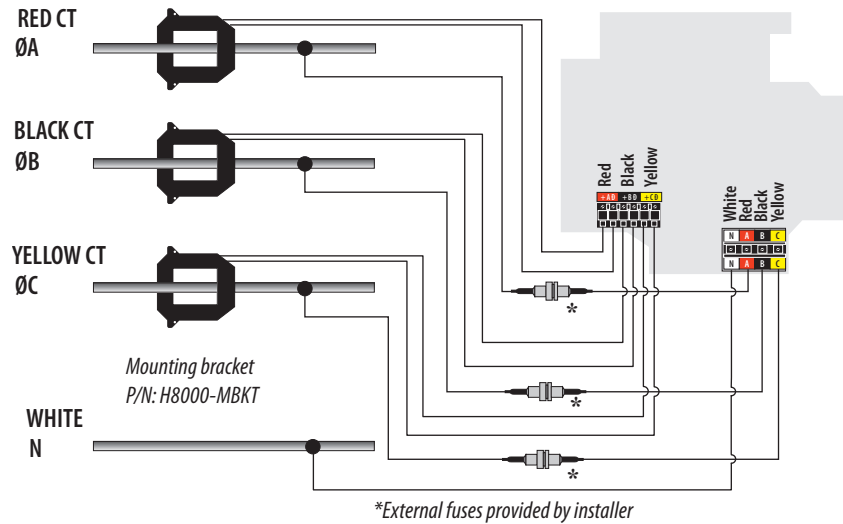

TYPICAL 240/120 VAC, 3-WIRE, 1Ø INSTALLATION

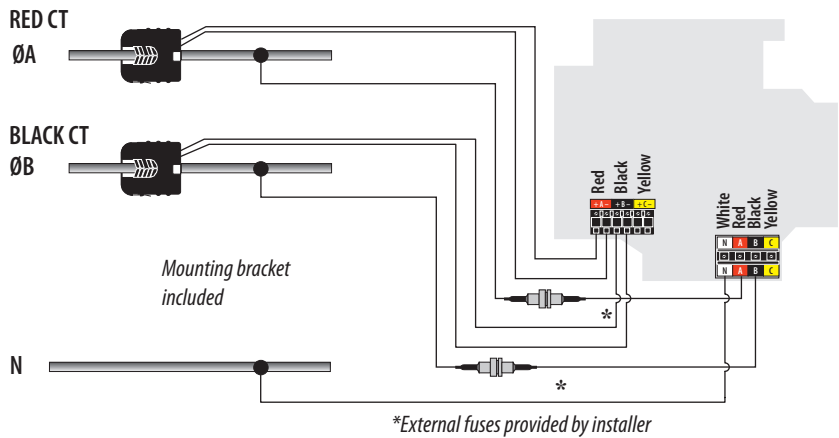

TYPICAL 120 VAC, 2-WIRE, 1Ø INSTALLATION

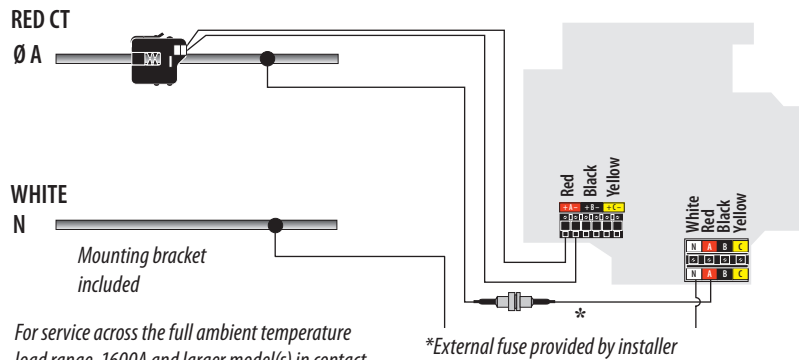

For service across the full ambient temperature load range, 1600A and larger model(s) in contact with a power conductor must be used with 90°C wire insulation, or be derated appropriately.

INSTALLATION INSTRUCTIONS

Wire the pulse output (pictured below) to the controller. Output is an electronic N.O. "contact closure" rated for 24V AC/DC @ 100mA maximum. Ensure that installation method and insulation ratings comply with local and national electrical codes.

Connecting the Phase Loss Output to Control/Data Acquisition Systems.

Wire the phase loss output (pictured below) to the controller/DAQ system. Output is an electronic N.C. "contact closure" rated for 24V AC/DC @ 100mA. maximum. Ensure that installation method and insulation ratings comply with local and national electrical codes.

7. Set the Backlight Enable Jumper to the desired operating condition. Remove the jumper to disable the LCD backlight.

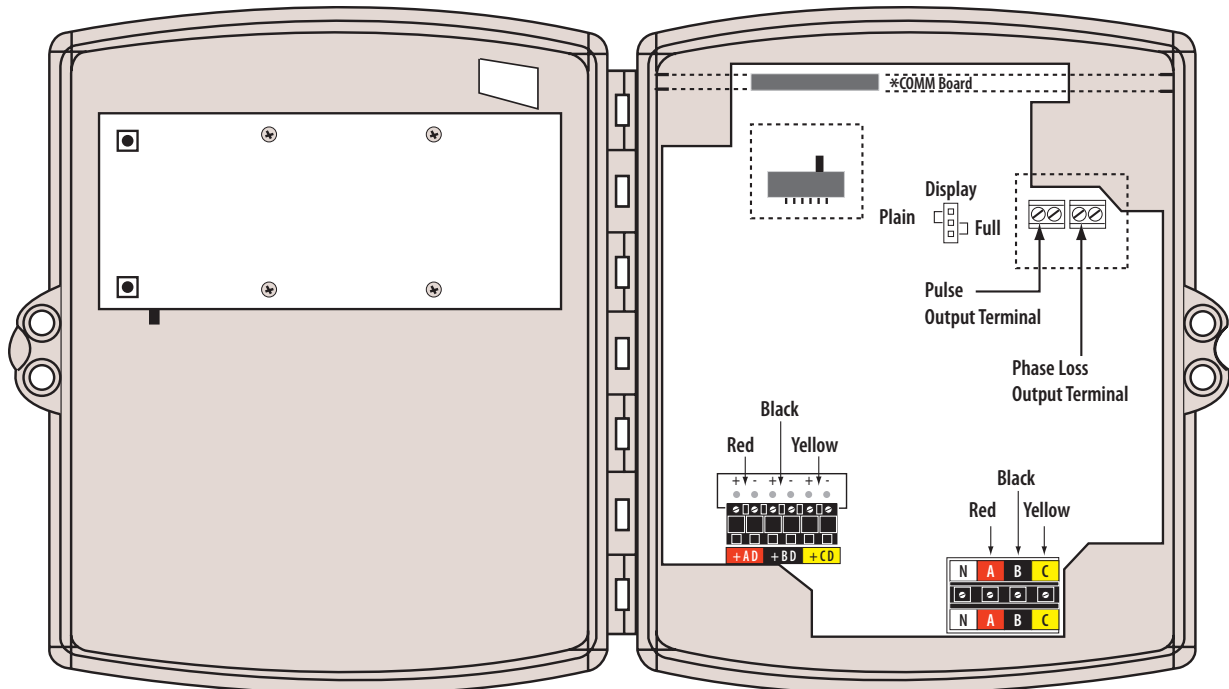
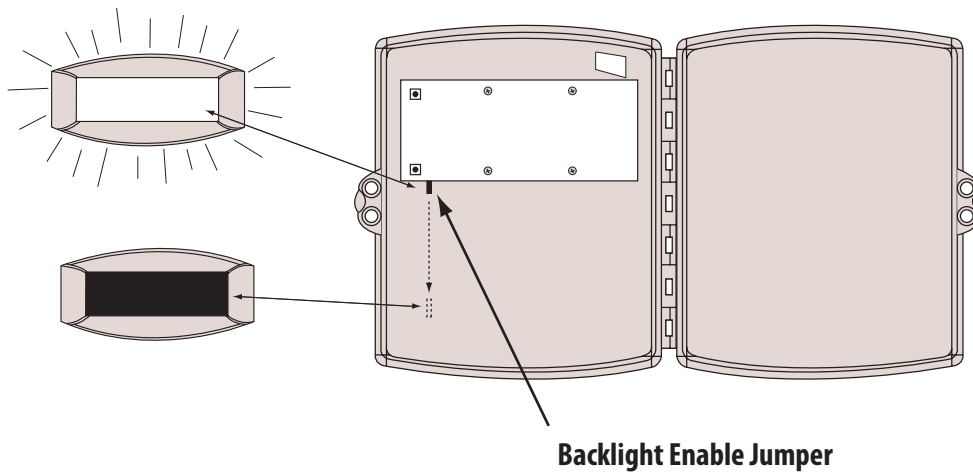

**COMM Board is Optional*

INSTALLATION INSTRUCTIONS

- Set the **Display Data Jumper** to select between the "Plain" and "Full" settings. The "Plain" mode cycles the display through five data elements (KW, max KW since last reset, average power factor, line-to-line voltage, and amps) for four seconds each. The "Full" mode cycles through all of the data available in the meter (all the above, plus KVAR, data on individual phases, etc.) as described on following page.

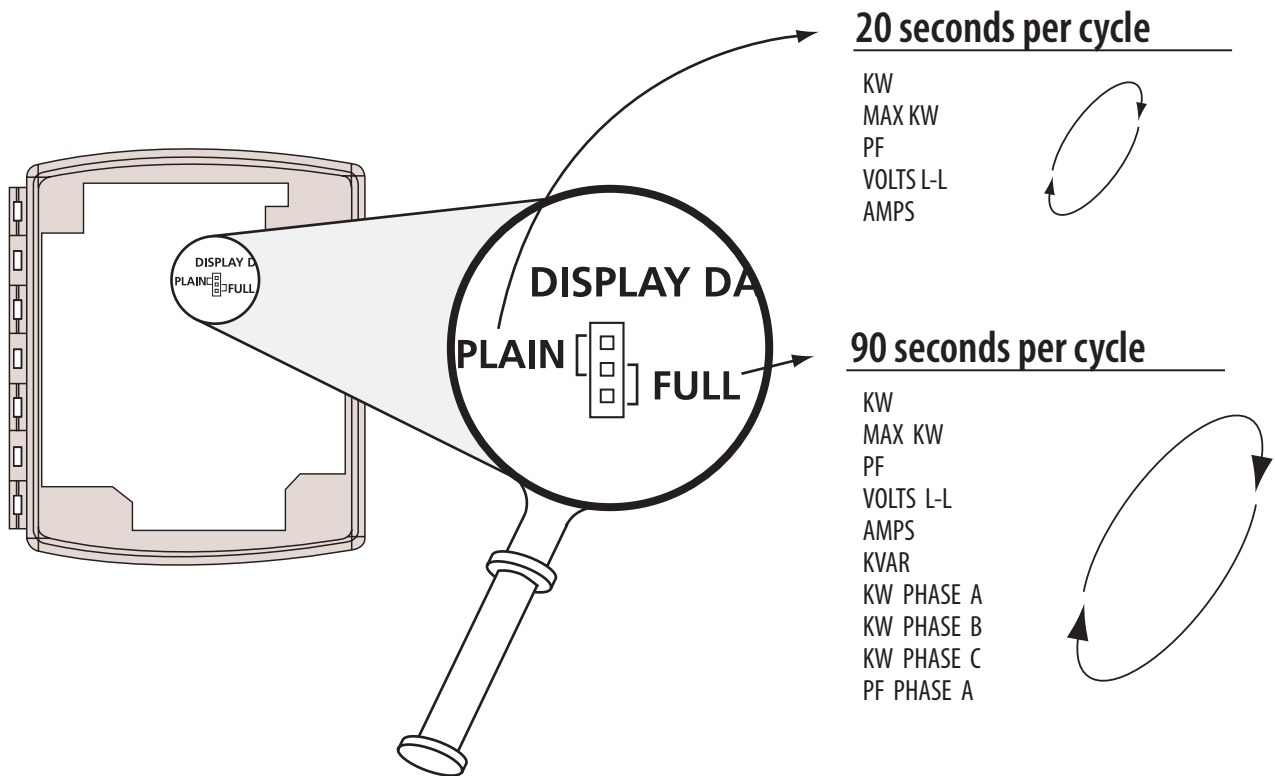

- Set **PULSE RATE Slide Switch**: Set to desired output rate. Note that 0.1 is not valid for 1600A systems, and 0.1 and 0.25 are not available for 2400A systems.
- Apply power to the meter.**
- Check the meter display.** The meter checks each phase to ensure that the phasing is correct. If the phasing is correct the meter responds with OKAY, if the phasing of the CT and voltage leads are incorrect, the meter displays, ERROR CHECK WIRES RED* CT RED* VOLT LEAD SAME PHASE. *appropriate color
- Approximate check of power reading:

Check actual current with amp clamp. Expected power is:

$$kW = \text{Volts} \times \text{Amps} \times 1.732 \times \text{PF} / 1000$$

$$kW = \text{Horsepower} \times .746$$

INSTALLATION INSTRUCTIONS

Operation and Information Reporting

Power-Up

On power-up, the meter displays the firmware revision. It then checks each connection to ensure that the CT and voltage leads have been properly matched. A warning message will indicate each phase which has been found to be mismatched (note: the meter uses low Power Factor to determine improper phase matching).

Information Displayed When Meter is Running

The energy meter continually reports kilowatt hours (KWH) or megawatt hours (MWH), depending on the the total energy accumulated.

A secondary display cycles through other parameters. There are two modes of operation, depending on the setting of the DISPLAY DATA jumper (J8) on the main circuit board:

PLAIN: KW, MAX-KW, PF, VOLTS, AMPS

FULL: KW, PF, VOLTS, AMPS, KVAR, KW-A**, KW-B**, KW-C***, PF-A**, PF-B**,
PF-C***, VOLTS A-B***, VOLTS B-C***, VOLTS A-C***, VOLTS A-N**,
VOLTS B-N**, VOLTS C-N***, AMPS-A**, AMPS-B**, AMPS-C***

Every 10th rotation of parameters, the following parameters are also displayed:

PULSE-RATE****, ADDRESS*, BAUD-RATE*, PARITY*, 2/4WIRE*

*Only if Comms board installed

**2 and 3-CT meters only

***3-CT meters only

Alarms

The following alarm messages remain on the lower display as long as the alarm condition persists:

Phase Loss	If the voltage of any phase is measured as less than 75% of the voltage on any other phase, the display will show PHASE LOSS and indicate the problem phase(s).
Over Current	If the measured current is greater than 110% of the rated CT range, the display will show AMPS OVER and indicate the problem phase(s).
Over Voltage	Volts A-C, B-C or A-C is greater than 660VAC. If an error is detected, the display will show VOLTS OVER and indicate the problem phase(s).

Meter/Display Configuration

KWh Reset: Press and hold the two pushbuttons on the back of the LCD display board for about 10 seconds to zero the KWH accumulator.

KW Max. Reset: Press and hold the two pushbuttons on the back of the LCD display board for about 5 seconds to zero the KW max. register.

TROUBLESHOOTING

Problem	Check	Solution
No Display	Voltage at Voltage Terminals Is the input power to the meter switched?	Check External Fuses We recommend that the voltage connections be made to a point ahead of commonly operated switches, motor controllers, etc.
	Check Display cable	Assure that the ribbon cable from the main circuit board to the display has not been disconnected during installation.
	Check Wiring to product	Is A-N Voltage other than 100-300VAC correct voltage input.
	Check CT POWER terminals (holes on PC board)	Don't allow conductive materials (wire clippings, etc) to short between the holes in the main board near the CT Terminals, as these connect to the main power supply.
Too much, or too little display data	Display Data Jumper	Set jumper to correct position
No IR communication	Angle and distance of handheld from IR window	Hold the handheld 12" away from, and within a 20° cone from the lower left corner of the IR window (dark area at the upper left corner of the meter)
No pulse output (if equipped)	Supply voltage	The pulse output is a contact closure only – power must be supplied externally in the range of 5 – 24V AC/DC, with a maximum load of 100mA
	Signal Timing	The pulse output provides a contact closure for 200ms at each pulse time. Assure that the controller will accept this signal as an input.
Pulse output wrong, Display O.K	Pulse Rate Switch	Set the pulse rate switch and controller to match. Pulse rate switch selects 0.1,0.25,0.5, or 1.0 kWh/Pulse Note that 0.1 is not valid for 1600A systems, and 0.1 and 0.25 are not available for 2400A systems.
Phase Loss output (if equipped)	Always on	This output is normally closed (N.C.). Therefore it is closed at all times when the meter is correctly powered.
	No output	This output is a contact closure only and requires an external power supply in the range of 5-24V AC/DC, with a maximum load of 100mA
Reported power too low	CT match to voltage leads	The CT's must be mounted around the corresponding voltage lead's power conductor, e.g., the red CT must be mounted to the power conductor connected to the red voltage lead (the same is true for any other CT/voltage lead pairs). Check for phase loss Check fuses in voltage leads (field installed)
Reported power inaccurate	Check CT serial numbers	The CT's are calibrated to individual meters and must be connected to the meter they were calibrated with to assure optimum accuracy.
"bAd" appears on the display	Pulse Rate Selection Switch	When an illegal pulse setting is selected, the KWH/PULSE segment is illuminated and "bAd" is shown on the lower display (only on H8163).
Accuracy not as specified	Check that CT serial numbers and Meter Serial numbers match	Meter and CT's sold as set with accuracy calibrated as a set.

SPECIFICATIONS

GENERAL SPECIFICATIONS

LCD display Physical 1.2" x 3.8" viewing area, 160 segments, back lit with green LEDs
Electrical services 100-300 VAC 1Ø/200-480 VAC 3Ø Y plus neutral
CT case isolation 600 VAC, IEC 1010 Cat. III pollution degree 2, alt. 0-2000 meters
Sample rate 1280 Hz.
Internal isolation 2500 VAC
Operating temp. range..... 0 to 50°C (<95%RH, non-condensing)
Storage temp. range..... -40°C to 70°C
Systems accuracy..... ±1% of reading from 2% to 100% of the CT current rating...accomplished by matching the CTs with a meter and calibrating them as a system
Power source 100-300 VAC (line-to-neutral) 50 VA
Voltage tolerance +10/-25% (90 - 132VAC line-to-neutral)
Services Any service where the A-N voltage is 300VAC nominal, and the phase-to-phase voltage is less than 520VAC
Frequency 50/60 Hz.
Safety UL 3111-1 Cat. III pollution degree 2, alt. 0-2000 meters
Protection Class NEMA 1

COMMS BOARD OPTION

Modbus Communications

Output type Modbus RTU
Connection 2-wire or 4-wire selectable
Baud rate 2400, 4800, 9600, 19200 baud
Parity None/Odd/Even Selectable
Address 1-63
Data Output refer to COMMS Board spec.

Inputs

Demand Reset Starts a new demand interval. Pulled-up to +5V via 4.7k. Contact closure or pull-to-ground. Edge-triggered