



Applicable Adaptable Affordable



# WINGMAN™

The Cobot Tool Changer system

BROCHURE & DATASHEETS V4.1

April 13<sup>th</sup> 2024



## APPLICABLE

No nonsens products

## AFFORDABLE

Best value for money

## ADAPTABLE

LEGO like customiization















### OUR MISSION

It's our mission to earn your trust and recognition as the world's best provider for automatic tool change for cobots

# WINGMAN™

## The Cobot Tool Changer system

### CONTENTS

	A- PRESENTATION	<b>A-1</b>	
	B- PART NUMBERS	<b>B-1</b>	
	C- KITS & COBOT CONNECTIVITY	<b>C-1</b>	
	D- SYSTEM OVERVIEW	<b>D-1</b>	
	E- DATASHEETS	<b>E-1</b>	
	F- SPARE PARTS	<b>F-1</b>	



## AUTOMATIC tool change on cobots

With automatic tool change on your cobot, your cobot can deploy more tools, finish more work and create more output

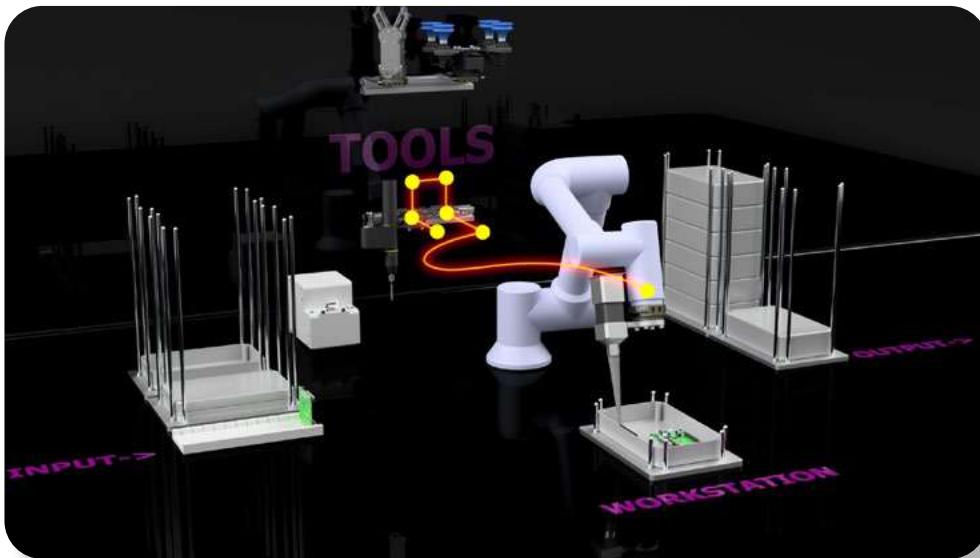
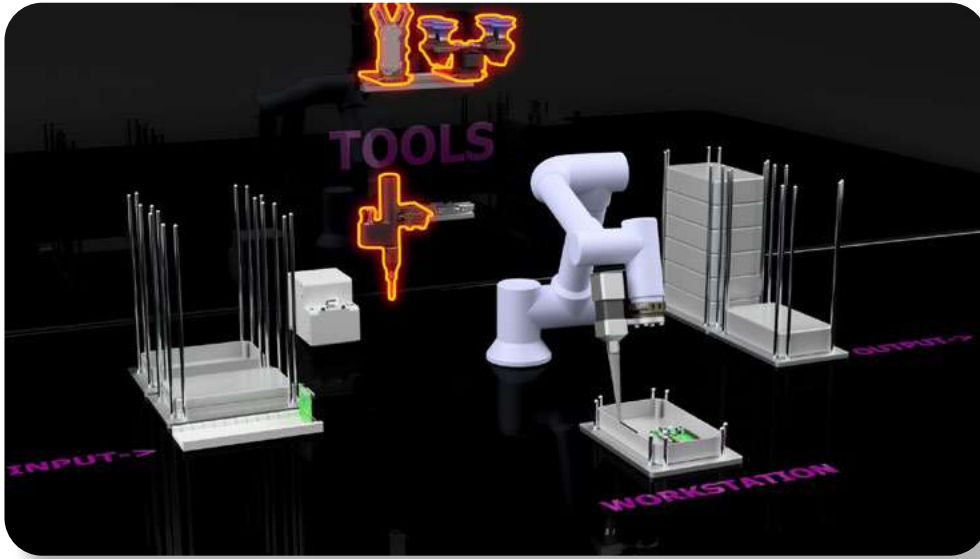



# A- PRESENTATION

## Tool Changer for cobots

The **WINGMAN™** system is installed and deployed for manual and automatic tool change in just a few minutes - **Plug & Play**. Just bolt on and teach waypoints.



© All rights reserved TripleA robotics APS 2024. Reservations are made for errors, incorrect, missing or obsolete information

## MANUAL & AUTOMATIC tool change in one device

The **WINGMAN™** system's **patented** mechanical locking mechanism provides easy manual and automatic tool change in one device without the need for electricity or compressed air.





## DESIGN & INNOVATION

The **WINGMAN™** system has been developed with design, function and safety in focus and with a one-fits-all concept in mind, which makes the **WINGMAN™** system the world's most versatile tool changer system for cobots.



## FEATURES

- Patented redundant locking mechanism
- Tested for cobot safety standard ISO/TS 15066
- Automatic tool change setup in minutes
- Integrates with most cobots and tools
- Modular pass-through



## SPECIFICATIONS

- See datasheet page: **E-2**
- Rated payload: 33kg (max 100kg)
- Repeatability:  $\pm 0,03\text{mm}$  /  $\pm 0,2\text{deg}$
- Weight, installed: 260g
- Height, installed: 30mm
- Material: CNC machined aluminum





## PASS-THROUGH adaptability

The **WINGMAN™** system accommodates up to 3 sets of pass-through modules to ensure fit with your favorite cobot and robotic tools



Suction Ø22 - Modules

Page **D-5**



Air 4MM - Built-in

Page **D-4**



Air 6MM - Modules

Page **D-4**



Electrical M8 - Modules

Page **D-3**



Electrical M12 - Modules

Page **D-3**



# B- PART NUMBERS

© All rights reserved TripleA robotics ApS 2024. Reservations are made for errors, incorrect, missing or obsolete information

See "Table 1" on page B-3

Illustration 1

- A Pass-through interface Robot side A
- B Pass-through interface Tool side B



© All rights reserved TripleA robotics APS 2024. Reservations are made for errors, incorrect, missing or obsolete information

Table 1 - Part numbers			Table 1	
Interface	Part number	Description	Datasheet	System
		*Look up the part number suffix <b>XXX</b> for your robot brand and model in "Table 2" on page C-3		
<b>WINGMAN™ Tool Changer kits</b>				
Kits for cobots	WM1-K-01-00-XXX*	One way WINGMAN manual kit, with built-in air pass-through	C-2	
	WM1-K-02-00-XXX*	Two way WINGMAN manual kit, with built-in air pass-through		
	WM1-K-03-00-XXX*	Two way WINGMAN automatic kit, with built-in air pass-through		
	WM1-K-04-00-XXX*	Two way WINGMAN automatic kit, with built-in air + M8 electrical pass-through (cables not included)		
	WM1-K-05-00-XXX*	Two way WINGMAN automatic kit, with built-in air + M8 electrical + High Flow air pass-through (cables not included)		
	WM1-DK-05-00-XXX*	Two way WINGMAN developer kit, with built-in air + M8 electrical + High Flow air pass-through + Accessories		
<b>WINGMAN™ Tool Changer</b>				
1	WM1-P-01-01-XXX*	Tool Changer, WM1 Robot Part <b>A</b>	E-2	D-2
1	WM1-P-02-01-XXX*	Tool Changer, WM1 Tool Part <b>B</b>	E-6	
3	WM1-P-03-01	Tool Changer, WM1 Tool Part Holder (necessary to achieve automatic tool change)		
<b>Pass-through - Electrical - M8/8pin/A-coded and accessories</b>				
<b>A</b>	WM1-A-01-01-01	Electrical module for WM1 Robot Part, M8, 8 pin, A-coded, female	E-8	D-3
<b>B</b>	WM1-A-01-02-01	Electrical module for WM1 Tool Part, M8, 8 pin, A-coded, male		
<b>B</b>	WM1-A-01-02-02a	Electrical module for WM1 Tool Part, M8, 8 pin, A-coded, female		
<b>A B</b>	WM1-A-02-01-...(options)	Electrical cable for electrical module: M8, 8 pin, A-code ( <b>Options!</b> For fit with your cobot see "Table 3" on page C-5)	E-12	
<b>B</b>	WM1-A-02-02-01	Electrical cable for electrical module, 5m, open end to M8, 8 pin, A-coded, L-shaped, female		
<b>A B</b>	WM1-A-02-02-02	Electrical cable for electrical module, 5m, open end to M8, 8 pin, A-coded, L-shaped, male	E-28	
<b>B</b>	WM1-A-08-02-01	Cap module for WM1 Tool Part (to protect module WM1-A-01-01-01)		
<b>Pass-through - Electrical - M12/5pin/A-coded and accessories</b>				
<b>A</b>	WM1-A-09-01-01a	Electrical module for WM1 Robot Part, M12, 5 pin, A-coded, male	E-10	D-3
<b>B</b>	WM1-A-09-02-01a	Electrical module for WM1 Tool Part, M12, 5 pin, A-coded, female		
<b>A B</b>	WM1-A-13-01-...(options)	Electrical cables, custom for M12, 5pin, A-coded ( <b>Options!</b> )		
<b>A</b>	WM1-A-13-02-01	Electrical cable, standard 5m, open end to M12, 5pin, A-coded, L-shaped female	E-13	
<b>B</b>	WM1-A-13-02-02	Electrical cable, standard 5m, open end to M12, 5pin, A-coded, L-shaped male		
<b>B</b>	WM1-A-08-02-02a	Cap module for WM1 Tool Part (to protect module WM1-A-09-01-01)	E-28	
<b>Pass-through - Electrical - M12/8pin/A-coded and accessories</b>				
<b>A</b>	WM1-A-10-01-01a	Electrical module for WM1 Robot Part, M12, 8 pin, A-coded, male	E-10	D-3
<b>B</b>	WM1-A-10-02-01a	Electrical module for WM1 Tool Part, M12, 8 pin, A-coded, female		
<b>A B</b>	WM1-A-20-01-...(options)	Electrical cables, custom for M12, 8pin, A-coded ( <b>Options!</b> )		
<b>A</b>	WM1-A-20-02-01	Electrical cable, standard 5m, open end to M12, 8pin, A-coded, L-shaped female	E-14	
<b>B</b>	WM1-A-20-02-02	Electrical cable, standard 5m, open end to M12, 8pin, A-coded, L-shaped male		
<b>B</b>	WM1-A-08-02-02a	Cap module for WM1 Tool Part (to protect module WM1-A-10-01-01)	E-28	
<b>Pass-through - Electrical - M12/12pin/A-coded and accessories</b>				
<b>A</b>	WM1-A-11-01-01a	Electrical module for WM1 Robot Part, M12, 12 pin, A-coded, male	E-10	D-3
<b>B</b>	WM1-A-11-02-01a	Electrical module for WM1 Tool Part, M12, 12 pin, A-coded, female		
<b>A B</b>	WM1-A-21-01-...(options)	Electrical cables, custom for M12, 12pin, A-coded ( <b>Options!</b> )		
<b>A</b>	WM1-A-21-02-01	Electrical cable, standard 5m, open end to M12, 12pin, A-coded, L-shaped female	E-15	
<b>B</b>	WM1-A-21-02-02	Electrical cable, standard 5m, open end to M12, 12pin, A-coded, L-shaped male		
<b>B</b>	WM1-A-08-02-02a	Cap module for WM1 Tool Part (to protect module WM1-A-11-01-01)	E-28	
<b>Pass-through - Electrical - Cables for special purposes (Cable adaptors)</b>				
	WM1-A-14-...(options)	Cables, special purpose and adaptor cables ( <b>Options!</b> )	E-16	
<b>Pass-through - Air - Ø4mm fittings for build-in ports and accessories</b>				
<b>A B</b>	WM1-A-06-01	Air push-in fittings I-shaped, M5 to Ø4mm hose, I-shaped (2 pcs. included)	E-20	D-4
<b>A B</b>	WM1-A-06-02	Air push-in fittings L-shaped, M5 to Ø4mm hose, I-shaped (2 pcs. included)		
<b>A B</b>	WM1-A-06-03	Air push-in fittings, plug M5 (2 pcs. included)		
<b>A B</b>	WM1-A-19-04-06	Air Y-splitter, 2*OD4mm to 1*OD6mm (2 pcs. included)		
<b>A B</b>	WM1-A-18-04-05	Air hose, OD4mm / ID2,6mm, 5m	E-22	
<b>A B</b>	WM1-A-18-06-05	Air hose, OD6mm / ID4mm, 5m		

© All rights reserved TripleA robotics APS 2024. Reservations are made for errors, incorrect, missing or obsolete information

See "Illustration 1" on page B-2

Table 1 - Part numbers			Table 1	
Interface	Part number	Description	Datasheet	System
<b>Pass-through - Air - Ø6mm modules and accessories</b>				
A	WM1-A-03-01	Air module with I-shaped push-in fittings included, 2 x Ø6mm: For WM1 Robot Part	E-18	D-4
B	WM1-A-03-02	Air module with I-shaped push-in fittings and plugs included, 2 x Ø6mm: For WM1 Tool Part		
A B	WM1-A-15-01	Air push-in fittings I-shaped, M7 to Ø6mm hose, I-shaped (2 pcs. included)	E-21	
A B	WM1-A-15-03	Air push-in fittings, plug M7 (2 pcs. included)		
A B	WM1-A-19-06-08	Air Y-splitter, 2*OD6mm to 1*OD8mm (2 pcs. included)	E-22	
A B	WM1-A-18-06-05	Air hose, OD6mm, 5m, ID4,0mm		
A B	WM1-A-18-08-05	Air hose, OD8mm, 5m, ID5,7mm		
<b>Pass-through - Suction - Ø22mm and accessories</b>				
A	WM1-A-12-01-01a	Suction module for Robot Part, Ø22mm	E-21	D-5
B	WM1-A-12-02-01a	Suction module for Tool Part, Ø22mm		
A B	WM1-A-16-00-01a	Suction module hose adaptor, Ø22mm, Type 1 (typically suitable for Robot side)	E-26	
A B	WM1-A-16-00-02a	Suction module hose adaptor, Ø22mm, Type 2 (typically suitable for Tool side)		
A B	WM1-A-17-00-05	Suction hose, spiral ID 25mm, Type 1, 5m (for suction module hose addaptor Type 1 and 2)	E-28	
B	WM1-A-08-02-02a	Cap module for WM1 Tool Part (to protect module WM1-A-12-01-01)		
<b>SPACEMAN™ Spacers</b>				
A B	SM1-P-10-01-01	SPACEMAN Spacer with distance, 10mm	E-30	D-5
A B	SM1-P-20-01-01	SPACEMAN Spacer with distance, 20mm		
<b>Other accessories</b>				
	WM1-A-05-01	Carry and storage case for WINGMAN kit (same as included in kit WM1-DK-05-00-....)		
<b>Spare parts</b>				
A	WM1-SK-01-00	WINGMAN Robot Part WM1-P-01-01-... - Spare part kit - Screw and pin kit	F-2	F-3
B	WM1-S-02-01	WINGMAN Tool Part WM1-P-02-01-... - Spare part - Screw set (4 pcs. included)		
B	WM1-S-02-02	WINGMAN Tool Part WM1-P-02-01-... - Spare part - Slider set (2 pcs. included)		
B	WM1-S-02-03	WINGMAN Tool Part WM1-P-02-01-... - Spare part - Spring, long set (2 pcs. included)		
B	WM1-S-02-04	WINGMAN Tool Part WM1-P-02-01-... - Spare part - Spring, short set (2 pcs. included)		
B	WM1-S-02-06	WINGMAN Tool Part WM1-P-02-01-... - Spare part - Pin set (4 pcs. included)		
B	WM1-S-02-07	WINGMAN Tool Part WM1-P-02-01-... - Spare part - Bearing set (4 pcs. included)		
B	WM1-S-02-08	WINGMAN Tool Part WM1-P-02-01-... - Spare part - Spring support set (2 pcs. included)		
B	WM1-S-02-10	WINGMAN Tool Part WM1-P-02-01-... - Spare part - O-ring set (5 pcs. included)		
B	WM1-S-02-11	WINGMAN Tool Part WM1-P-02-01-... - Spare part - Housing, middle (1 pcs. included)		
B	WM1-S-02-12	WINGMAN Tool Part WM1-P-02-01-... - Spare part - Housing, bottom (1 pcs. included)		
B	WM1-SK-01-01	WINGMAN Tool Part WM1-P-02-01-... - Spare part kit - Wear kit		
B	WM1-SK-01-02	WINGMAN Tool Part WM1-P-02-01-... - Spare part kit - Lock pad rep. kit		
B	WM1-SK-01-03	WINGMAN Tool Part WM1-P-02-01-... - Spare part kit - Lever rep. kit		

© All rights reserved TripleA robotics ApS 2024. Reservations are made for errors, incorrect, missing or obsolete information



# C- KITS & COBOT CONNECTIVITY



The WINGMAN™ Developer kit  
WM1-DK-05-00-XXX

All rights reserved TripleA robotics ApS 2024. Reservations are made for errors, incorrect, missing or obsolete information

Look up the part number suffix **XXX** for your robot brand and model in **"Table 2" on page C-3**

Kit part no.:	Kit description:	Illustration 2
WM1-DK-05-00-XXX	<b>DEVELOPER kit</b> , with built-in air + M8 electrical + High Flow air pass-through + Accessories	
WM1-K-05-00-XXX	<b>AUTOMATIC kit</b> , with built-in air + M8 electrical + High Flow air pass-through	
WM1-K-04-00-XXX	<b>AUTOMATIC kit</b> , with built-in air + M8 electrical pass-through	
WM1-K-03-00-XXX	<b>AUTOMATIC kit</b> with built-in air pass-through	
WM1-K-02-00-XXX	<b>MANUAL kit two way</b> , with built-in air pass-through	
WM1-K-01-00-XXX	<b>MANUAL kit one way</b> , with built-in air pass-through	

### KIT CONTENT AND QUANTITIES

<p>WM1-P-01-01-XXX Robot Part</p>	1	1	1	1	1	1
<p>WM1-P-02-01-XXX Tool Part</p>	1	2	2	2	2	2
<p>WM1-P-03-01 Tool Part Holder (necessary to achieve auto tool change)</p>			2	2	2	2
<p>WM1-A-01-01-01 Electrical Pass-Through for Robot Part</p>				1	1	1
<p>WM1-A-01-02-01 or WM1-A-01-02-02a (see native to cobot ● in "Table 3" on page C-5) M8 Electrical Pass-Through for Tool Part</p>				2	2	2
<p>WM1-A-02-01-... Cable to connect at cobot tool flange (TF) connector if available</p>						1
<p>WM1-A-03-01 High Flow air pass-through for Robot Part</p>				1	1	
<p>WM1-A-03-02 High Flow air pass-through for Tool Part</p>				2	2	
<p>WM1-A-06-01 Fittings set (2 pcs.) I-shaped for built-in air pass-through</p>						3
<p>SM1-P-10-01-01 and SM1-P-20-01-01 SPACEMAN™ Spacers in 10mm and in 20mm</p>						1+1
<p>WM1-A-05-01 Case for Developer kit</p>						1

© All rights reserved TripleA robotics ApS 2024. Reservations are made for errors, incorrect, missing or obsolete information

**Table 2 - Cobot specific part number suffix XXX**  
(Reservations are made for incorrect/obsolete data)

**Table 2**

Cobot Brand	Cobot Model	TC parts		Manual kits		Automatic kits				Electrical cable must be ordered separately for kit type <b>K-04</b> and <b>K-05</b> : TF = Connect at Tool Flange CC = Connect at Cabinet See cables page <b>E-12</b>
		WM1-P-01-01-XXX	WM1-P-02-01-XXX	WM1-K-01-00-XXX	WM1-K-02-00-XXX	WM1-K-03-00-XXX	Cables not included		WM1-DK-05-00-XXX	
							WM1-K-04-00-XXX	WM1-K-05-00-XXX		
ABB	GoFa CRB 15000	AB1	AB1	AB1	AB1	AB1	AB1 (1)	AB1 (1)	AB1	TF: (Not yet available) CC: WM1-A-02-02-02
AUBO	i3, i5, i7	AU1	AU1	AU1	AU1	AU1	AU1	AU1	AU1	TF: WM1-A-02-01-04 CC: WM1-A-02-02-02
AUBO	i10, i12, i16	AU1	AU1	AU1	AU1	AU1	AU1	AU1	AU1	TF: (Not yet available) CC: WM1-A-02-02-02
AUBO	i20	AU1 (3)	AU1	AU1 (3)	AU1 (3)	AU1 (3)	AU1 (2)(3)	AU1 (2)(3)	AU1 (3)	TF: (Not yet available) CC: WM1-A-02-02-02
Denso	COBOTTA PRO1300	DE1	DE1	DE1	DE1	DE1	DE1 (1)	DE1 (1)	DE1	TF: WM1-A-02-01-11 CC: WM1-A-02-02-02
Doosan Robotics	H2017, H2515, M0609, M0617, M1013, M1509, A0509, A0509s, A0912, A0912s	DR1	DR1	DR1	DR1	DR1	DR1	DR1	DR1	TF: WM1-A-02-01-03a CC: WM1-A-02-02-02
Fanuc	CRX: 5iA	FA1	FA1	FA1	FA1	FA1	FA1	FA1	FA1	TF: WM1-A-02-01-01 CC: WM1-A-02-02-02
Fanuc	CRX: 10iA, 10iA/L, 20iA/L	FA1	FA1	FA1	FA1	FA1	FA1	FA1	FA1	TF: WM1-A-02-01-07 CC: WM1-A-02-02-02
Fanuc	CRX: 25iA	FA2	FA2	FA2	FA2	FA2	FA2 (2)	FA2 (2)	FA2	TF: WM1-A-02-01-07 CC: WM1-A-02-02-02
Hans Robot	Elfin3, Elfin5, Elfin10	HR1	HR1	HR1	HR1	HR1	HR1	HR1	HR1	TF: (Not yet available) CC: WM1-A-02-02-02
Kassow	KR810, KR1018, KR1205, KR1410, KR1805	KA1	KA1	KA1	KA1	KA1	KA1	KA1	KA1	TF: WM1-A-02-01-05 CC: WM1-A-02-02-02
Kuka	LBR iiwa	KU1	KU1	KU1	KU1	KU1	KU1	KU1	KU1	TF: (Configurable) CC: WM1-A-02-02-02
Kuka	LBR iisy	KU2	KU2	KU2	KU2	KU2	KU2 (2)	KU2 (2)	KU2	TF: (Not yet available) CC: WM1-A-02-02-02
Omron	TM5-700, TM5-900, TM12, TM14, TM16, TM20	OM1	OM1	OM1	OM1	OM1	OM1	OM1	OM1	TF: WM1-A-02-01-02a CC: WM1-A-02-02-02
Techman	TM5-700, TM5-900, TM12, TM14, TM16, TM20	TM1	TM1	TM1	TM1	TM1	TM1	TM1	TM1	TF: WM1-A-02-01-02a CC: WM1-A-02-02-02
Universal Robots	UR3cb, UR3e, UR5cb, UR5e (Before April 2024 = male TF connector)	UR1	UR1	UR1	UR1	UR1	UR1	UR1	UR1	TF: WM1-A-02-01-01 CC: WM1-A-02-02-02
	UR10cb, UR10e, UR16e (Before April 2024 = male TF connector)	UR1	UR1	UR1	UR1	UR1	UR1	UR1	UR1	TF: WM1-A-02-01-07 CC: WM1-A-02-02-02
	UR3e, UR5e (After April 2024 = female TF connector)	UR2	UR2	UR2	UR2	UR2	UR2	UR2	UR2	TF: WM1-A-02-01-12 CC: WM1-A-02-02-02
	UR10e, UR16e (After April 2024 = female TF connector)	UR2	UR2	UR2	UR2	UR2	UR2	UR2	UR2	TF: WM1-A-02-01-10 CC: WM1-A-02-02-02
	UR20, UR30	UR2 (3)	UR2 (3)	UR2 (3)	UR2 (3)	UR2 (3)	UR2 (2)(3)	UR2 (2)(3)	UR2 (3)	TF: WM1-A-02-01-10 CC: WM1-A-02-02-02

- (1) 1 pcs. SM1-P-10-01-01 must be ordered separately.
- (2) 1 pcs. SM1-P-10-01-01 + 1 pcs. SM1-P-20-01-01 must be ordered separately.
- (3) Standard ISO adaptor flange must be installed to convert TF flange from 6 holes to 4 holes (not provided by TripleA robotics).

© All rights reserved TripleA robotics APS 2024. Reservations are made for errors, incorrect, missing or obsolete information

See "Table 3" on page C-5

Illustration 3

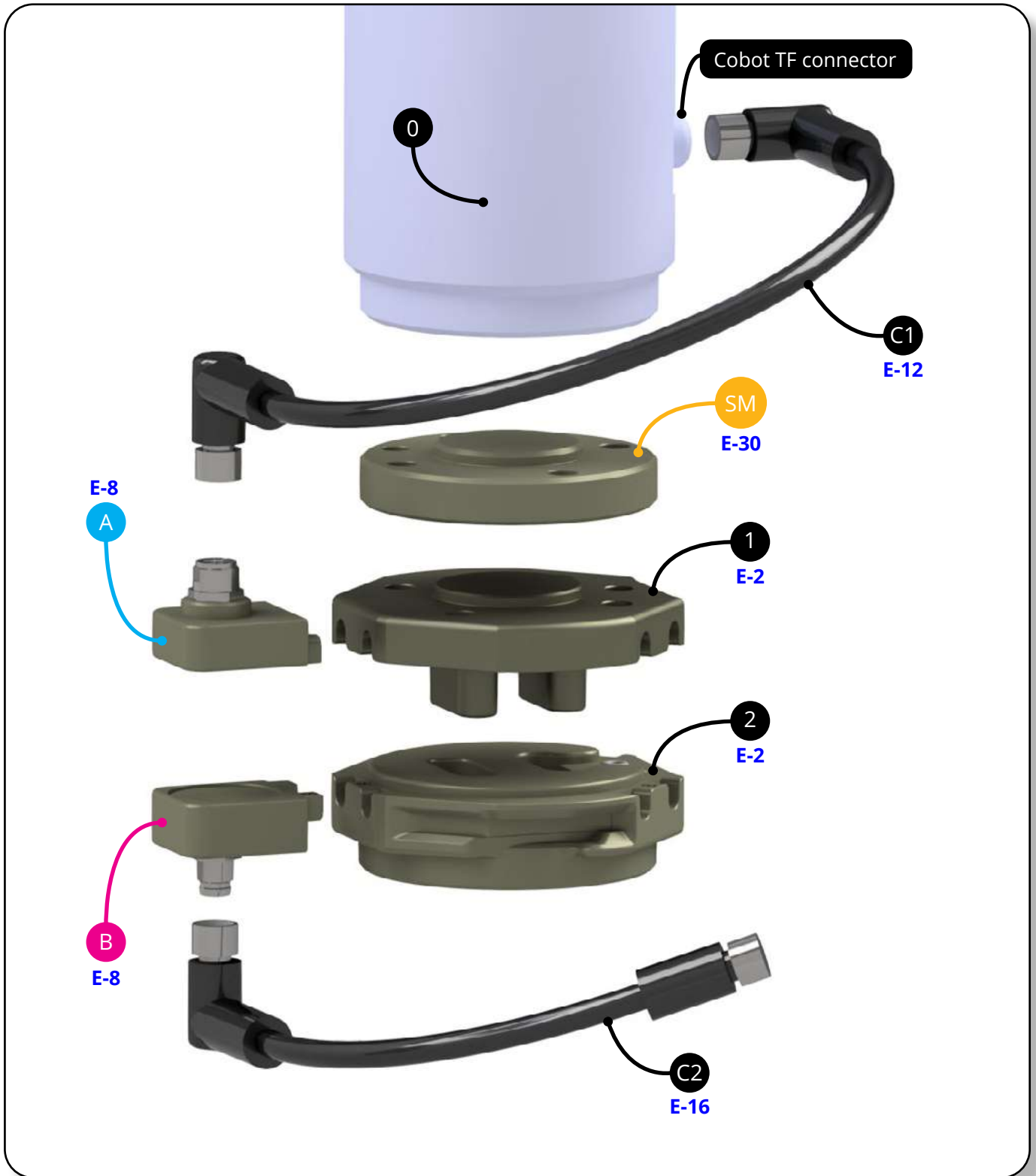

© All rights reserved TripleA robotics ApS 2024. Reservations are made for errors, incorrect, missing or obsolete information



**Table 3 - Cobot tool flange (TF) connector pass-through**

(Reservations are made for incorrect and obsolete data)

**Table 3**

Cobot		Cable from cobot TF connector to WINGMAN™	Electrical module robot side	<span style="color:red">●</span> Native to cobot (same as cobot TF) <span style="color:green">●</span> M8/8pin male connector towards tool <span style="color:blue">●</span> M8/8pin female connector towards tool		Spacer if required to ensure room for the electrical modules and cable
Brand	Model			Electrical module tool side	Adaptor cable if required	
		0	A	B	C2	SM
ABB	GoFa CRB 15000	(Not yet available)	WM1-A-01-01-01	WM1-A-01-02-01 <span style="color:green">●</span> WM1-A-01-02-02a <span style="color:blue">●</span>	(Not yet available)	1 pcs. SM1-P-10-01-01
AUBO	i3, i5, i7	WM1-A-02-01-04	WM1-A-01-01-01	WM1-A-01-02-01 <span style="color:green">●</span> <span style="color:red">●</span> WM1-A-01-02-02a <span style="color:blue">●</span>	NaN	NaN
AUBO	i10, i12, i16	(Not yet available)	WM1-A-01-01-01	WM1-A-01-02-01 <span style="color:green">●</span> <span style="color:red">●</span> WM1-A-01-02-02a <span style="color:blue">●</span>	NaN	NaN
AUBO	i20	(Not yet available)	WM1-A-01-01-01	WM1-A-01-02-01 <span style="color:green">●</span> <span style="color:red">●</span> WM1-A-01-02-02a <span style="color:blue">●</span>	NaN	1 pcs. SM1-P-10-01-01 1 pcs. SM1-P-20-01-01
Denso	COBOTTA PRO1300	WM1-A-02-01-11	WM1-A-01-01-01	WM1-A-01-02-01 <span style="color:green">●</span> <span style="color:red">●</span> WM1-A-01-02-02a <span style="color:blue">●</span>	NaN	1 pcs. SM1-P-10-01-01
Doosan Robotics	H2017, H2515, M0609, M0617, M1013, M1509, A0509, A0509s, A0912, A0912s	WM1-A-02-01-03a	WM1-A-01-01-01	WM1-A-01-02-01 <span style="color:green">●</span> WM1-A-01-02-02a <span style="color:blue">●</span> <span style="color:red">●</span>	NaN	NaN
Fanuc	CRX: 5iA	WM1-A-02-01-01	WM1-A-01-01-01	WM1-A-01-02-01 <span style="color:green">●</span> <span style="color:red">●</span> WM1-A-01-02-02a <span style="color:blue">●</span>	NaN	NaN
Fanuc	CRX: 10iA, 10iA/L, 20iA/L	WM1-A-02-01-07	WM1-A-01-01-01	WM1-A-01-02-01 <span style="color:green">●</span> <span style="color:red">●</span> WM1-A-01-02-02a <span style="color:blue">●</span>	NaN	NaN
Fanuc	CRX: 25iA	WM1-A-02-01-07	WM1-A-01-01-01	WM1-A-01-02-01 <span style="color:green">●</span> <span style="color:red">●</span> WM1-A-01-02-02a <span style="color:blue">●</span>	NaN	1 pcs. SM1-P-10-01-01 1 pcs. SM1-P-20-01-01
Hans Robot	Elfin3, Elfin5, Elfin10	(Not yet available)	WM1-A-01-01-01	WM1-A-01-02-01 <span style="color:green">●</span> WM1-A-01-02-02a <span style="color:blue">●</span>	(Not yet available)	NaN
Kassow	KR810, KR1018, KR1205, KR1410, KR1805	WM1-A-02-01-05	WM1-A-01-01-01	WM1-A-01-02-01 <span style="color:green">●</span> <span style="color:red">●</span> WM1-A-01-02-02a <span style="color:blue">●</span>	NaN	NaN
Kuka	LBR iiwa	(Configurable)	WM1-A-01-01-01	WM1-A-01-02-01 <span style="color:green">●</span> WM1-A-01-02-02a <span style="color:blue">●</span>	(Not yet available)	NaN
Kuka	LBR iisy	(Not yet available)	WM1-A-01-01-01	WM1-A-01-02-01 <span style="color:green">●</span> WM1-A-01-02-02a <span style="color:blue">●</span>	(Not yet available)	1 pcs. SM1-P-10-01-01 1 pcs. SM1-P-20-01-01
Omron	TM5-700, TM5-900, TM12, TM14, TM16, TM20	WM1-A-02-01-02a	WM1-A-01-01-01	WM1-A-01-02-01 <span style="color:green">●</span> WM1-A-01-02-02a <span style="color:blue">●</span> <span style="color:red">●</span>	NaN	NaN
Techman	TM5-700, TM5-900, TM12, TM14, TM16, TM20	WM1-A-02-01-02a	WM1-A-01-01-01	WM1-A-01-02-01 <span style="color:green">●</span> WM1-A-01-02-02a <span style="color:blue">●</span> <span style="color:red">●</span>	NaN	NaN
Universal Robots	UR3cb, UR3e, UR5cb, UR5e (Before September 2024 = Male TF connector)	WM1-A-02-01-01	WM1-A-01-01-01	WM1-A-01-02-01 <span style="color:green">●</span> <span style="color:red">●</span> WM1-A-01-02-02a <span style="color:blue">●</span>	NaN	NaN
	UR10cb, UR10e, UR16e (Before September 2024 = Male TF connector)	WM1-A-02-01-07	WM1-A-01-01-01	WM1-A-01-02-01 <span style="color:green">●</span> <span style="color:red">●</span> WM1-A-01-02-02a <span style="color:blue">●</span>	NaN	NaN
	UR3e, UR5e (After September 2024 = Female TF connector)	WM1-A-02-01-12	WM1-A-01-01-01	WM1-A-01-02-01 <span style="color:green">●</span> WM1-A-01-02-02a <span style="color:blue">●</span> <span style="color:red">●</span>	NaN	NaN
	UR10e, UR16e (After September 2024 = Female TF connector)	WM1-A-02-01-10	WM1-A-01-01-01	WM1-A-01-02-01 <span style="color:green">●</span> WM1-A-01-02-02a <span style="color:blue">●</span> <span style="color:red">●</span>	NaN	NaN
	UR20, UR30 (Option 1)	WM1-A-02-01-10	WM1-A-01-01-01	WM1-A-01-02-01 <span style="color:green">●</span> WM1-A-01-02-02a <span style="color:blue">●</span> <span style="color:red">●</span>	NaN	1 pcs. SM1-P-10-01-01 1 pcs. SM1-P-20-01-01 (Original UR ISO flange adaptor must be applied)
	UR20, UR30 (Option 2)	WM1-A-14-01-02	WM1-A-10-01-01a	WM1-A-10-02-01a	WM1-A-14-01-03 <span style="color:green">●</span> WM1-A-14-01-04 <span style="color:blue">●</span> <span style="color:red">●</span>	NaN

© All rights reserved TripleA robotics APS 2024. Reservations are made for errors, incorrect, missing or obsolete information



© All rights reserved TripleA robotics APS 2024. Reservations are made for errors, incorrect, missing or obsolete information



# D- SYSTEM OVERVIEW

## SYSTEM OVERVIEW

WINGMAN™ Tool Changer	D-2
Pass-through - Electrical - M8	D-3
Pass-through - Electrical - M12	D-3
Pass-through - Air - Ø4mm build-in	D-4
Pass-through - Air - Ø6mm module	D-4
Pass-through - Suction - Ø22mm	D-5
SPACEMAN™ Spacers	D-5

# SYSTEM OVERVIEW

## WINGMAN™ Tool Changer



Look up the part number suffix **XXX** for your robot brand and model in **"Table 2"** on page C-3

AUTOMATIC tool change														
MANUAL tool change														
Robot Part	Tool Part	Tool Part Holder (necessary to achieve automatic tool change)												
<table border="1"> <tr> <th>Part number:</th> <th>Page:</th> </tr> <tr> <td>WM1-P-01-01-<b>XXX</b></td> <td><b>E-2</b></td> </tr> </table>	Part number:	Page:	WM1-P-01-01- <b>XXX</b>	<b>E-2</b>	<table border="1"> <tr> <th>Part number:</th> <th>Page:</th> </tr> <tr> <td>WM1-P-02-01-<b>XXX</b></td> <td><b>E-2</b></td> </tr> </table>	Part number:	Page:	WM1-P-02-01- <b>XXX</b>	<b>E-2</b>	<table border="1"> <tr> <th>Part number:</th> <th>Page:</th> </tr> <tr> <td>WM1-P-03-01</td> <td><b>E-6</b></td> </tr> </table>	Part number:	Page:	WM1-P-03-01	<b>E-6</b>
Part number:	Page:													
WM1-P-01-01- <b>XXX</b>	<b>E-2</b>													
Part number:	Page:													
WM1-P-02-01- <b>XXX</b>	<b>E-2</b>													
Part number:	Page:													
WM1-P-03-01	<b>E-6</b>													

- A** Pass-through interface Robot side A
- B** Pass-through interface Tool side B



© All rights reserved TripleA robotics ApS 2024. Reservations are made for errors, incorrect, missing or obsolete information



# SYSTEM OVERVIEW

## Pass-through - Electrical - M8



To find the right pass-through for your cobot's TF connector, please see **"Table 3"** on page C-5

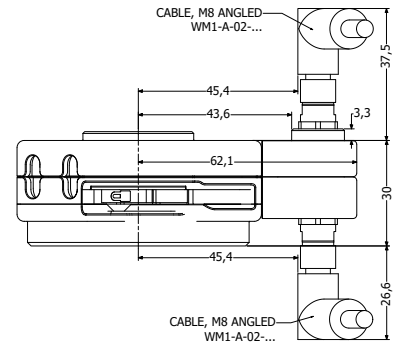

Electrical modules - M8, A-code		
Part No.	Description	Page
M8 - 8pin - 30V - 1,5A (3A peak)		
A WM1-A-01-01-01	Robot side, female	E-8
B WM1-A-01-02-01	Tool side, male	
B WM1-A-01-02-02a	Tool side, female	
Cap module to protect M8 Robot side module		
B WM1-A-08-02-01	Tool side cap, size 1	E-28

Cables - M8, A-code		
Example photos		
Part No.	Description	Page
M8 - 8pin		
A B WM1-A-02-01-...	Custom, M8-8pin cables	E-12
B WM1-A-02-02-01	Female to open-end, 5m	
A B WM1-A-02-02-02	Male to open-end, 5m	

## Pass-through - Electrical - M12

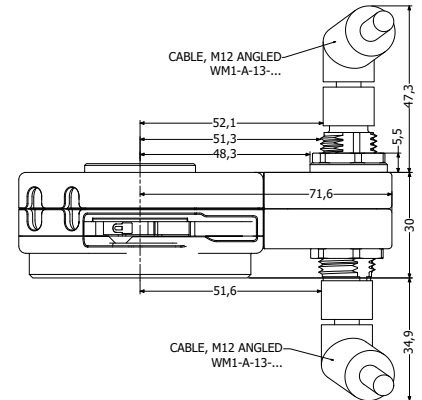

Electrical modules - M12, A-code		
Part No.	Description	Page
M12 - 5pin - A coded - 60V - 4A (6A peak)		
A WM1-A-09-01-01a	Robot side, male	E-10
B WM1-A-09-02-01a	Tool side, female	
M12 - 8pin - A coded - 30V - 2A (3A peak)		
A WM1-A-10-01-01a	Robot side, male	E-10
B WM1-A-10-02-01a	Tool side, female	
M12 - 12pin - A coded - 30V - 1,5A (3A peak)		
A WM1-A-11-01-01a	Robot side, male	E-10
B WM1-A-11-02-01a	Tool side, female	
Cap module to protect M12 Robot side module		
B WM1-A-08-02-02a	Tool side cap, size 2	E-28

Cables - M12, A-code		
Example photos		
Part No.	Description	Page
M12 - 5pin - A coded		
A B WM1-A-13-01-...	Custom, M12-5pin cables	E-13
A WM1-A-13-02-01	Female to open-end, 5m	
B WM1-A-13-02-02	Male to open-end, 5m	
M12 - 8pin - A coded		
A B WM1-A-20-01-...	Custom, M12-8pin cables	E-14
A WM1-A-20-02-01	Female to open-end, 5m	
B WM1-A-20-02-02	Male to open-end, 5m	
M12 - 12pin - A coded		
A B WM1-A-21-01-...	Custom, M12-12pin cables	E-15
A WM1-A-21-02-01	Female to open-end, 5m	
B WM1-A-21-02-02	Male to open-end, 5m	

© All rights reserved TripleA robotics APS 2024. Reservations are made for errors, incorrect, missing or obsolete information

# SYSTEM OVERVIEW

## Pass-through - Air - Ø4mm build-in



**Push-in fittings - M5 to 4mm hose**

Part No.	Description	Page
Up to 6-10 bar (temp. dependent)		
WM1-A-06-01	I-Shape, 2 pcs.	E-20
WM1-A-06-02	L-Shape, 2 pcs.	
WM1-A-06-03	Plugs, 2 pcs.	

**Air hose 4mm**

Part No.	Description	Page
WM1-A-18-04-05	OD4mm / ID2,6mm, 5m	E-22

**Air hose Y-splitter**

Part No.	Description	Page
WM1-A-19-04-06	2*Ø4 to 1*Ø6	E-22

**Air hose 6mm**

Part No.	Description	Page
WM1-A-18-06-05	OD6mm / ID4mm, 5m	E-22

## Pass-through - Air - Ø6mm module

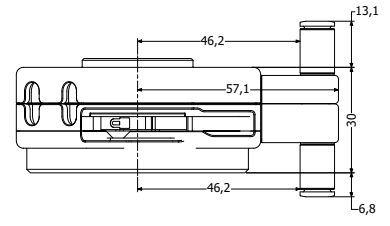

**Air modules with push-in fittings - M7 to 6mm hose**

Part No.	Description	Page
Up to 6-10 bar (temp. dependent)		
WM1-A-03-01	Robot side, I-shape, 2*Ø6 OD	E-18
WM1-A-03-02	Tool side, I-shape, 2*Ø6 OD	
WM1-A-03-02	Tool side, cap (plugs included)	

**Air hose 6mm**

Part No.	Description	Page
WM1-A-18-06-05	OD6mm / ID4mm, 5m	E-22



**Air hose Y-splitter**

Part No.	Description	Page
WM1-A-19-06-08	2xØ6 to 1xØ8	E-22

**Air hose 8mm**

Part No.	Description	Page
WM1-A-18-08-05	OD8mm / ID5,7mm, 5m	E-22

# SYSTEM OVERVIEW

## Pass-through - Suction - Ø22mm

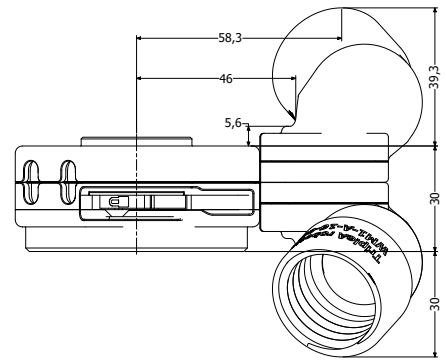

Suction modules, ID 22mm		
		
Part No.	Description	Page
ID 22mm, -0,9 to 0 bar (not for air pressure)		
<b>A</b> WM1-A-12-01-01a	Robot side, suction	<b>E-24</b>
<b>B</b> WM1-A-12-02-01a	Tool side, suction	
Cap module to protect suction module		
<b>B</b> WM1-A-08-02-02a	Tool side cap. size 2	<b>E-28</b>

Hose adaptors, ID 22mm		
		
Part No.	Description	Page
ID 22mm, -0,9 to 0 bar (not for air pressure)		
<b>A</b> WM1-A-16-00-01a	Hose adaptor, type 1	<b>E-26</b>
<b>B</b> WM1-A-16-00-02a	Hose adaptor, type 2	

Hose, spiral		
		
Part No.	Description	Page
<b>A</b> WM1-A-17-01-05	OD32mm / ID25mm, 5m	<b>E-26</b>

## SPACEMAN™ Spacers



Spacers		
		
Part No.	Description	Page
ISO 9409-1-50-4-M6 flange on both sides		
<b>A</b> SM1-P-10-01-01	10 mm spacer	<b>E-30</b>
<b>B</b> SM1-P-20-01-01	20 mm spacer	

© All rights reserved TripleA robotics ApS 2024. Reservations are made for errors, incorrect, missing or obsolete information





TripleA  
robotics

WINGMAN  
THE COBOT TOOL CHANGER SYSTEM

WINGMAN  
THE COBOT TOOL CHANGER SYSTEM

All rights reserved TripleA Robotics AG 2024. Re-creation, any modification, reproduction, distribution, or use of this document is prohibited. All other trademarks, trade names, or product names are the property of their respective owners. All information is subject to change without notice. Please refer to the latest version of this document for the most up-to-date information.



# E- DATASHEETS

## CONTENTS

WINGMAN™ Tool Changer - Robot Part and Tool Part	<b>E-2</b>
WINGMAN™ Tool Changer - Tool Part Holder	<b>E-6</b>
Pass-through - Electrical - Module - M8	<b>E-8</b>
Pass-through - Electrical - Module - M12	<b>E-10</b>
Pass-through - Electrical - Cable - M8/8pin	<b>E-12</b>
Pass-through - Electrical - Cable - M12/5pin	<b>E-13</b>
Pass-through - Electrical - Cable - M12/8pin	<b>E-14</b>
Pass-through - Electrical - Cable - M12/12pin	<b>E-15</b>
Pass-through - Electrical - Cable - Cable adaptors	<b>E-16</b>
Pass-through - Air - Module - Ø6mm	<b>E-18</b>
Pass-through - Air - Fittings Ø4mm/M5	<b>E-20</b>
Pass-through - Air - Fittings Ø6mm/M7	<b>E-21</b>
Pass-through - Air - Hoses	<b>E-22</b>
Pass-through - Suction - Module - Ø22mm	<b>E-24</b>
Pass-through - Suction - Module - Ø22mm hose adaptor	<b>E-26</b>
Pass-through - Module - Cap	<b>E-28</b>
SPACEMAN™ spacers	<b>E-30</b>



**WM1-P-01-01...**  
The WINGMAN Robot Part

**WM1-P-02-01...**  
The WINGMAN Tool Part

### General information

PROPERTIES	
Installed weight on robot:	260g
Installed height on robot:	30mm
Rated Payload (Maximum Payload): (1) (2)	33kg (100kg)
Repeatability:	+ - 0,03mm and + -0,15 deg.
Flanges on Robot Part and Tool Part:	ISO 9409-1-50-4-M6
Housing material:	Surface treated aluminum (Color tone may vary)
Screws and dowel pin for Robot Part, included:	4 x M6x12mm (ISO10642/BN2100) 1 x Ø6h6 (DIN6325/BN858)
(1) The allowed payload for the specific application must be calculated. See page <a href="#">E-4</a>	
(2) For automatic tool change application, make sure to also check and comply with the payload limits for the WINGMAN Tool Part Holder (PN: WM1-P-03-...). See page <a href="#">E-6</a> .	

### Pass-through air ports, built-in



PASS-THROUGH, BUILT-IN AIR	
Built-in air ports:	2 pcs.
Port threads / Intended for hose size:	M5 / Ø4mm
Pressure range:	-0,9 to 10 bar
<b>I-shaped</b> (not included):	PN: WM1-A-06-01 (Ø4mm hose)
<b>L-shaped</b> (not included):	PN: WM1-A-06-02 (Ø4mm hose)

### Pass-through modules



PASS-THROUGH, MODULES	
Pass-through modules (not included):	Up to 3 sets of pass-through modules can be installed.

### Warning

Please read the WINGMAN User Guide page 1!

To prevent overload and damage to the Tool Part levers (Repair kit WM-SK-01-03), the cobots Robot Limits (safety feature that limits robot force) must be set to a maximum of **100N** to apply as the cobot performs the automatic tool change sequence.



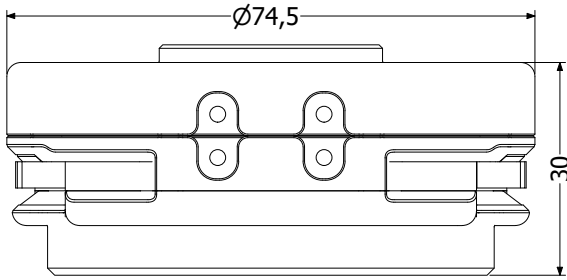

Tool Changer part for **robot** side (side A)



Tool Changer part for **tool** side (side B)



**WM1-P-01-01-...**

*The WINGMAN™ Robot Part for the cobot*



**WM1-P-02-01-...**

*The WINGMAN™ Tool Part for each tool deployed*

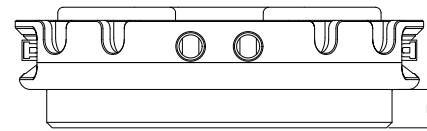
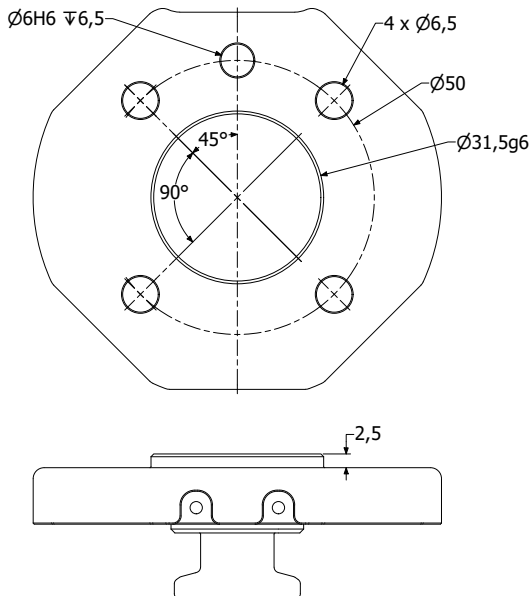

**Important:**  
Maximum tool bolt insertion depth 6,5mm!

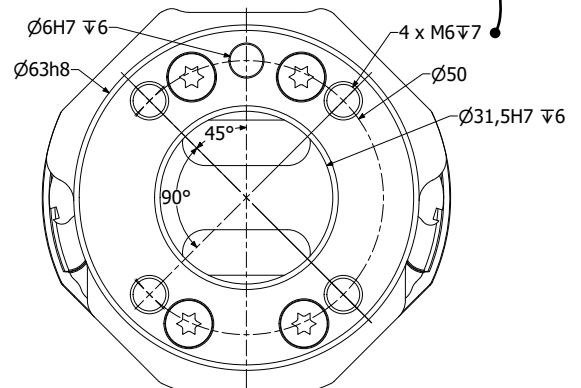



### PAYLOAD CALCULATION

**G,max** => The maximum dynamic force that can arise in the application all scenarios considered.  
**Dmb** => Distance from the Tool Part (TF) center to the payloads Center of Gravity that causes Mb torque.  
**Dmt** => Distance from the Tool Part (TF) center to the payloads Center of Gravity that causes Mt torque.  
**F,max** = 1000N (constant)  
**Mb,max** = 80N (constant)  
**Mt,max** = 80N (constant)

	F	Mb	Mt
<b>Formulas:</b>	$F_{max} / G_{max} / 9,82$	$Mb_{max} / G_{max} / Dmb / 9,82$	$Mt_{max} / G_{max} / Dmt / 9,82$
<b>Example calculation*:</b>	<ul style="list-style-type: none"> <li>Maximum dynamic force, <math>G_{max} = 2</math>.</li> <li>Distance, <math>Dmt = 0,1 m</math>.</li> <li>Distance, <math>Dmb = 0,12 m</math>.</li> </ul>	$80 Nm / 2 / 0,12m / 9,82 = 33Kg^*$	$80 Nm / 2 / 0,10m / 9,82 = 40kg$

\*The lowest weight calculated between **F, Mb, MT** is 33kg in the example which means that maximum 33kg is allowed on the robot at  $Dmt=0,1m$ ,  $Dmb=0,12m$  and  $G_{max}=2$ .

### PAYLOAD SAFETY FACTOR

Above formulas and example calculations are with a **safety factor of 5** to the tool changers yield strength. In case the consequence of failure is high, a **safety factor of 10** should be used instead and more frequent inspections must be made in accordance with the WINGMAN User Guide. To translate the calculated payload values from safety factor 5 to safety factor 10 simply multiply the values with 5/10. 33kg at safetyfacot 5 will translate to 16,5kg.

#### Mb

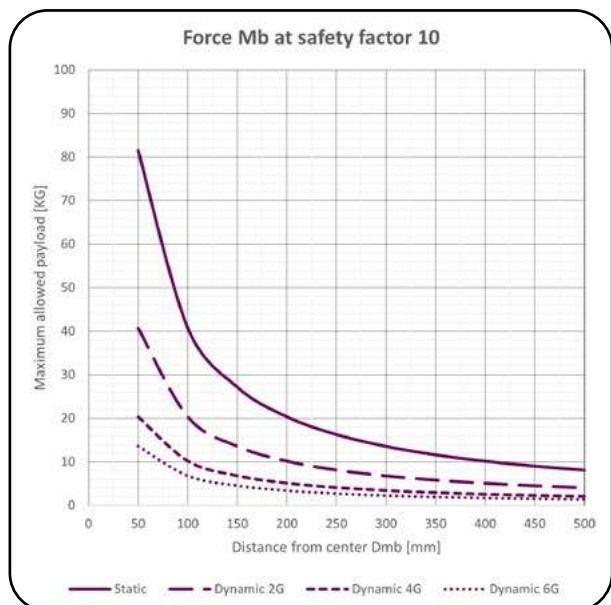
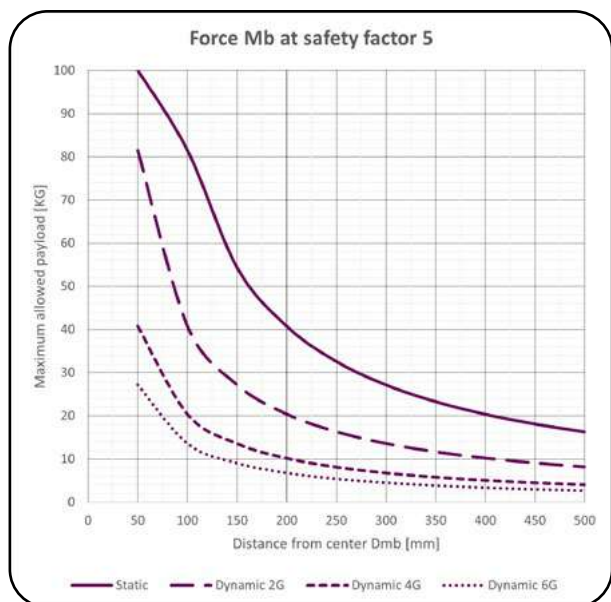

#### Mt

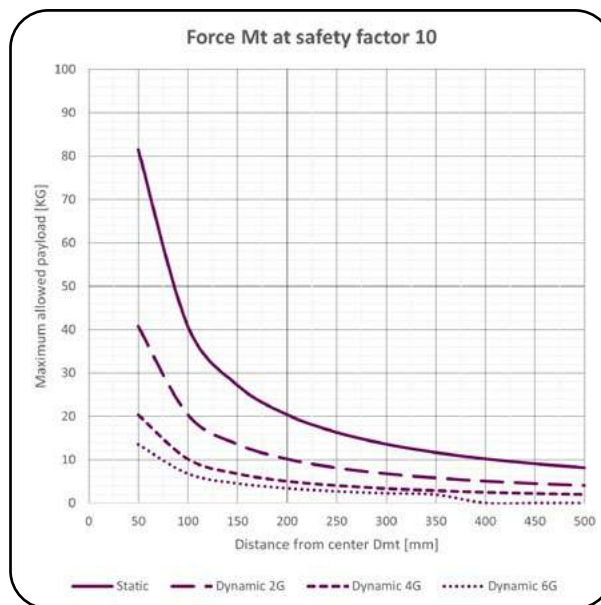
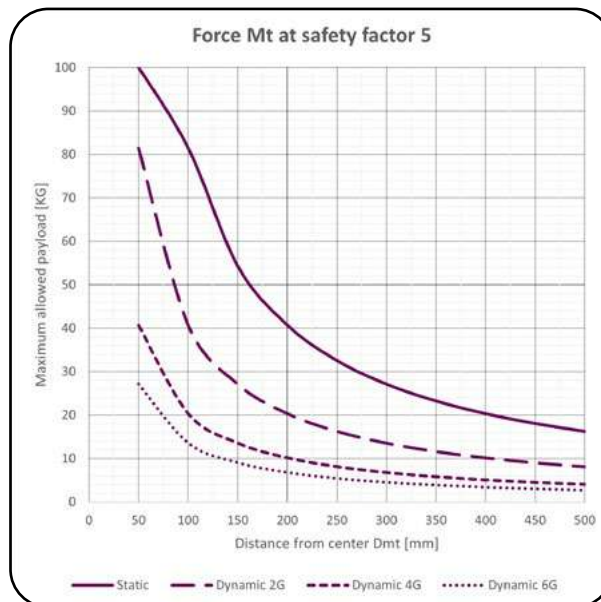

© All rights reserved TripleA robotics ApS 2024. Reservations are made for errors, incorrect, missing or obsolete information

BLANK  
PAGE





**WM1-P-03-01**  
Tool Part Holder

### General information

The WINGMAN Tool Part Holder (WM1-P-03-01) provides automatic tool change capability to the WINGMAN Tool Changer system. The Tool Part Holder interacts mechanically with the WINGMAN Tool Part (WM1-P-02-01-01).



PROPERTIES	
Weight:	254g
Material:	Stainless Steel 304 (surface gloss may vary)
Payload and imbalance, maximum: <sup>(1)</sup>	5kg and 1Nm
Installation:	Horizontally on rigid structure
Installation method:	M6 wing screws
WINGMAN approx. resistance for automatic tool change:	30-40N
(1) The allowed payload for the specific application must comply with the maximum <b>Payload Limits</b> to achieve smooth and reliable automatic tool change.	

### Waypoints for automatic tool change

Basic automatic tool change is simply a matter of teaching your cobot a few waypoints to move the WINGMAN Tool Part (WM1-P-02-01-01) in to and out of the WINGMAN Tool Part Holder (WM1-P-03-01).



### Warning

Please read the WINGMAN User Guide page 1!

To prevent overload and damage to the Tool Part levers (Repair kit WM-SK-01-03), the cobots Robot Limits (safety feature that limits robot force) must be set to a maximum of **100N** to apply as the cobot performs the automatic tool change sequence.



© All rights reserved TripleA robotics ApS 2024. Reservations are made for errors, incorrect, missing or obsolete information

### Payload Limits

TOOL PART HOLDER PAYLOAD LIMITS	
F,max (Rated couple payload):	50 N / 5 kg
Mt+, max (Rated couple torque):	1 Nm
Mt-, max (Rated couple torque):	0 Nm
Mb, max (Rated couple torque):	1 Nm

To achieve reliable and long lasting automatic tool change with the WINGMAN™ Cobot Tool Changer system, please make sure to comply within the Tool Part Holder payload limits.

The tool's balance (maximum 1Nm of imbalance) is of importance to achieve smooth and reliable automatic tool change.

Tool change with heavier tools than 5 kg/1Nm is possible but will require a custom-made bracket solution to support the tool weight and imbalance as coupling and decoupling takes place

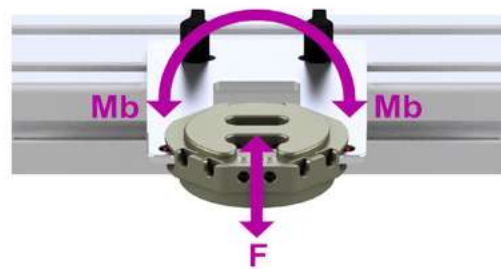
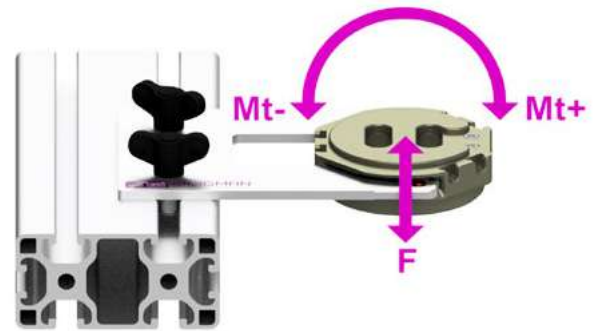

### Lubrication

In case you are running the WINGMAN™ system on the limits of the Tool Part Holder's payload limits and are experiencing unreliable automatic tool change, then lubricating the Tool Part Holder is likely to help.

We recommend using a silicone based silicone grease.

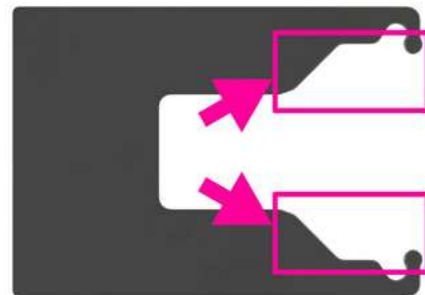

### WM1-A-03-01

Tool Part Holder for each tool deploys

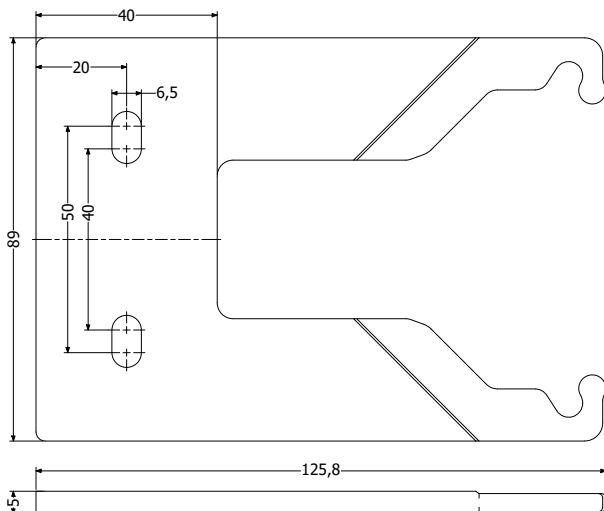

© All rights reserved TripleA robotics ApS 2024. Reservations are made for errors, incorrect, missing or obsolete information

**WM1-A-01-01-01**



**WM1-A-01-02-01**  
**WM1-A-01-02-02a**

### General information

The M8 electrical modules are suitable for plug and play with most cobots, which usually has the standard M8, 8pin connector available at the robot tool flange (TF). 5m cables are available as well as special cables that fits between the WINGMAN and the cobot tool flange (TF) connector.

The electrical modules are intended for passing through electricity to the robot tool. The modules have no electronic parts inside.

INTERFACES AND PROPERTIES	
<b>Connector:</b>	<b>M8, 8 pins</b>
Rated voltage AC/DC:	30V
Rated current at 40°C per pin (peak):	1,5A (3A)
Shielded pass-through:	No
Connector type:	Circular M8
Connector code:	A-coded
Applicable standard:	IEC 61076-2-104
IP classification when engaged:	Minimum IP54
Housing material:	Surface treated aluminum (Color tone may vary)

### Warning

Power to the pass-through module must be turned off and any residual electricity must be eliminated before tool change takes place. Failing in doing so may result in damage or premature wear of the WINGMAN electric modules and can result in injury caused by unexpected behaviour by the robot tool.



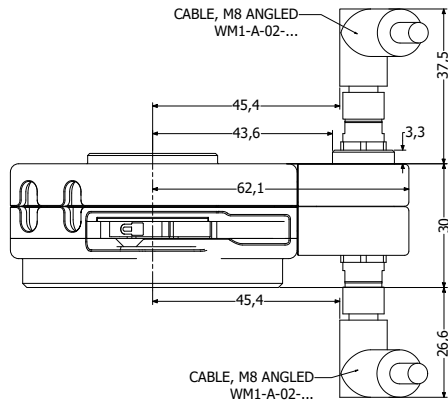

### Modules for **robot** side (side A)



**WM1-A-01-01-01**

M8, 8pin, A-coded, female for Robot Part



### Modules for **tool** side (side B)



**WM1-A-01-02-01**

M8, 8pin, A-coded, male for Tool Part



MATCH

**WM1-A-01-02-02a**

M8, 8pin, A-coded, female for Tool Part



MATCH

**WM1-A-08-02-01**

Cap module for size 1 for Tool Part



MATCH

© All rights reserved TripleA robotics APS 2024. Reservations are made for errors, incorrect, missing or obsolete information

WM1-A-09-01-01a  
 WM1-A-10-01-01a  
 WM1-A-11-01-01a



WM1-A-09-02-01a  
 WM1-A-10-02-01a  
 WM1-A-11-02-01a

### General information

5m cables are available to connect between the WINGMAN M12 module and your control box, PLC, robot tool etc.

0,3m pigtail cables are available so you can convert a standard M12 cable with a straight connector (I-shaped) into an angled connector (L-shaped) which is a good fit for the WINGMAN system.

The electrical modules are intended for passing through electricity to the robot tool. The modules have no electronic parts inside.

INTERFACES AND PROPERTIES			
Connector	M12, 5 pin	M12, 8 pin	M12, 12 pin
Rated voltage AC/DC:	60V	30V	30V
Rated current at 40°C per pin (peak):	4A (6A)	2A (3A)	1,5A (3A)
Shielded pass-through:	Yes	Yes	No
Connector type:	Circular M12		
Connector code:	A-coded		
Applicable standard:	IEC 61076-2-101		
IP classification when engaged:	Minimum IP54		
Housing material:	Surface treated aluminum (Color tone may vary)		

### Warning

Power to the pass-through module must be turned off and any residual electricity must be eliminated before tool change takes place. Failing in doing so may result in damage or premature wear of the WINGMAN electric modules and can result in injury caused by unexpected behaviour by the robot tool.





Part number: WM1-A-09-..., WM1-A-10-..., WM1-A-11-...

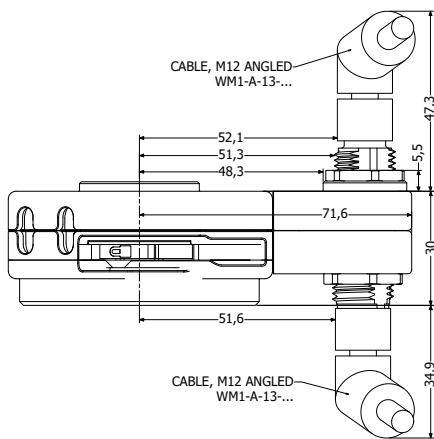

Modules for **robot** side (side A)

Modules for **tool** side (side B)



**WM1-A-09-01-01a**

**WM1-A-09-02-01a**

M12, 5pin, A-coded, male for Robot Part

M12, 5pin, A-coded, female for Tool Part

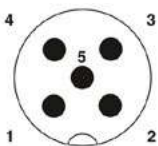

MATCH

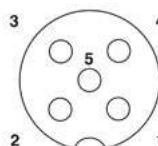

**WM1-A-10-01-01a**

**WM1-A-10-02-01a**

M12, 8pin, A-coded, male for Robot Part

M12, 8pin, A-coded, female for Tool Part

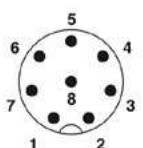

MATCH

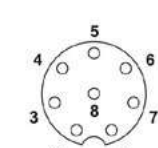

**WM1-A-11-01-01a**

**WM1-A-11-02-01a**

M12, 12pin, A-coded, male for Robot Part

M12, 12pin, A-coded, female for Tool Part

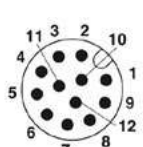

MATCH

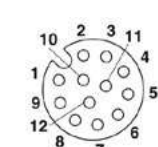

WM1-A-09-01-01a  
WM1-A-10-01-01a  
WM1-A-11-01-01a

**WM1-A-08-02-02a**

Cap module for size 2 for Tool Part

MATCH



© All rights reserved TripleA robotics APS 2024. Reservations are made for errors, incorrect, missing or obsolete information

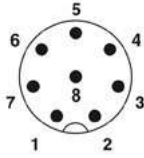

Pos.	Wire
1	WH
2	BN
3	GN
4	YE
5	GY
6	PK
7	BU
8	RD

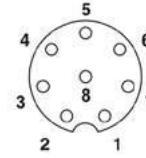

Gender male (M)



Gender female (F)

Orientation pin (rotation) can be different from the picture. Cables can be with green or black mold. Conn. angle 90 deg => L-Shaped  
Conn. angle 0 deg => I-Shaped

### Cables

Cable PN	Fits to WINGMAN™ module PN			Cable connector <b>A</b> (Intended for WINGMAN™ module)						Cable length [m]	Cable connector <b>B</b> (Intended for robot or tool end)					
	WM1-A-01-01	WM1-A-01-02-01	WM1-A-01-02-02a	Type	Pins	Gender	Rotation (deg.)*	Code	Conn. angle (deg.)		Type	Pins	Gender	Rotation (deg.)*	Code	Conn. angle (deg.)
WM1-A-02-02-01	-	A	-	M8	8	F	0	A	90	5	Open-end					
WM1-A-02-02-02	A	-	A	M8	8	M	0	A	90	5	Open-end					
WM1-A-02-01-01	A	B	A	M8	8	M	0	A	90	0,22	M8	8	F	0	A	90
WM1-A-02-01-02a	A	-	-	M8	8	M	0	A	90	0,17	M8	8	M	90	A	90
WM1-A-02-01-03a	A	-	-	M8	8	M	0	A	90	0,25	M8	8	M	270	A	90
WM1-A-02-01-04	A	-	-	M8	8	M	0	A	90	0,22	M8	8	F	270	A	90
WM1-A-02-01-05	A	-	-	M8	8	M	0	A	90	0,25	M8	8	F	135	A	90
WM1-A-02-01-06	A	B	A	M8	8	M	0	A	90	0,25	M8	8	F	0	A	90
WM1-A-02-01-07	A	B	A	M8	8	M	0	A	90	0,30	M8	8	F	0	A	90
WM1-A-02-01-08	-	B	-	M8	8	F	0	A	90	0,22	M8	8	F	0	A	90
WM1-A-02-01-09	A	B	A	M8	8	M	0	A	90	0,22	M8	8	F	180	A	90
WM1-A-02-01-10	A	-	A	M8	8	M	0	A	90	0,30	M8	8	M	0	A	90
WM1-A-02-01-11	A	B	A	M8	8	M	0	A	90	0,17	M8	8	F	0	A	90
WM1-A-02-01-12	A	-	A	M8	8	M	0	A	90	0,22	M8	8	M	0	A	90

(Cable length may vary up to 5-10%)

© All rights reserved TripleA robotics ApS 2024. Reservations are made for errors, incorrect, missing or obsolete information

# DATASHEET

## Pass-through - Electrical - Cable - M12/5pin



Part number: WM1-A-13-...

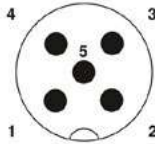

Gender male (M)

Pos.	Wire
1	BN
2	WH
3	BU
4	BK
5	GN/YE (Grey)

Orientation pin (rotation) can be different from the picture. Cables can be with green or black cap.  
Conn. angle 90 deg => L-Shaped  
Conn. angle 0 deg => I-Shaped

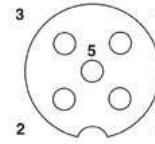

Gender female (F)

### Cables

Cable PN	Fits to WINGMAN™ module PN		Cable connector <b>A</b> (Intended for WINGMAN™ module)						Length [m]	Cable connector <b>B</b> (Intended for robot or tool end)					
	WM1-A-09-01-01a	WM1-A-09-02-01a	Type	Pins	Gender	Rotation (deg.)	Code	Conn. angle (deg.)		Type	Pins	Gender	Rotation (deg.)	Code	Conn. angle (deg.)
WM1-A-13-02-01	A	-	M12	5	F	0	A	90	5	Open-end					
WM1-A-13-02-02	-	A	M12	5	M	0	A	90	5	Open-end					
WM1-A-13-01-01	(B)	A	M12	5	M	0	A	90	0,3	M12	5	F	0	A	0
WM1-A-13-01-04	A	(B)	M12	5	F	0	A	90	0,3	M12	5	M	0	A	0

(B) = Not recommended to use this cable end to connect to the WINGMAN™ module because this connector end is I-shaped (Conn. angle = 0 deg.) which takes up more space and therefore risk of collision with the robot arm is greater.

(Cable length may vary up to 5-10%)

© All rights reserved TripleA robotics APS 2024. Reservations are made for errors, incorrect, missing or obsolete information

# DATASHEET

## Pass-through - Electrical - Cable - M12/8pin



Part number: WM1-A-20-...

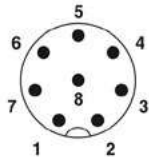

Pos.	Wire
1	WH
2	BN
3	GN
4	YE
5	GY
6	PK
7	BU
8	RD

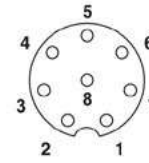

Orientation pin (rotation) can be different from the picture. Cables can be with green or black cap.  
 Conn. angle 90 deg => L-Shaped  
 Conn. angle 0 deg => I-Shaped

Gender male (M)

Gender female (F)

### Cables

Cable PN	Fits to WINGMAN™ module PN		Cable connector <b>A</b> (Intended for WINGMAN™ module)						Length [m]	Cable connector <b>B</b> (Intended for robot or tool end)					
	WM1-A-10-01-01a	WM1-A-10-02-01a	Type	Pins	Gender	Rotation (deg.)	Code	Conn. angle (deg.)		Type	Pins	Gender	Rotation (deg.)	Code	Conn. angle (deg.)
WM1-A-20-02-01	A	-	M12	8	F	0	A	90	5	Open-end					
WM1-A-20-02-02	-	A	M12	8	M	0	A	90	5	Open-end					
WM1-A-20-01-01	(B)	A	M12	8	M	0	A	90	0,3	M12	8	F	0	A	0
WM1-A-20-01-04	A	(B)	M12	8	F	0	A	90	0,3	M12	8	M	0	A	0

(B) = Not recommended to use this cable end to connect to the WINGMAN™ module because this connector end is I-shaped (Conn. angle = 0 deg.) which takes up more space and risk of collision with the robot arm is greater.

(Cable length may vary up to 5-10%)

© All rights reserved TripleA robotics ApS 2024. Reservations are made for errors, incorrect, missing or obsolete information

# DATASHEET

## Pass-through - Electrical - Cable - M12/12pin



Part number: WM1-A-21-...

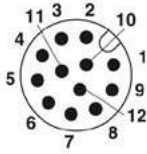

Gender male (**M**)

Pos.	Wire
1	BN
2	BU
3	WH
4	GN
5	PK
6	YE
7	BK
8	GY
9	RD
10	VT
11	OR (or GYPK)
12	Light GN (or

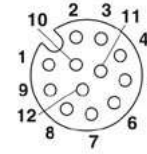

Gender female (**F**)

Orientation pin (rotation) can be different from the picture. Cables can be with green or black cap.  
Conn. angle 90 deg => L-Shaped  
Conn. angle 0 deg => I-Shaped

### Cables

Cable PN	Fits to WINGMAN™ module PN		Cable connector <b>A</b> (Intended for WINGMAN™ module)						Length [m]	Cable connector <b>B</b> (Intended for robot or tool end)					
	WM1-A-11-01-01a	WM1-A-11-02-01a	Type	Pins	Gender	Rotation (deg.)	Code	Conn. angle (deg.)		Type	Pins	Gender	Rotation (deg.)	Code	Conn. angle (deg.)
WM1-A-21-02-01	A	-	M12	12	F	0	A	90	5	Open-end					
WM1-A-21-02-02	-	A	M12	12	M	0	A	90	5	Open-end					
WM1-A-21-01-01	(B)	A	M12	12	M	0	A	90	0,3	M12	12	F	0	A	0
WM1-A-21-01-04	A	(B)	M12	12	F	0	A	90	0,3	M12	12	M	0	A	0

(B) = Not recommended to use this cable end to connect to the WINGMAN™ module because this connector end is I-shaped (Conn. angle = 0 deg.) which takes up more space and risk of collision with the robot arm is greater.

(Cable length may vary up to 5-10%)

© All rights reserved TripleA robotics ApS 2024. Reservations are made for errors, incorrect, missing or obsolete information



These cables convert between different types of connectors in each end and are designed for special designated purposes such as fit with a specific robot or robotics tool.

### Cables

Cable PN	Fits to WINGMAN™ module PN						Cable connector <b>A</b> (Intended for WINGMAN™ module)						Length [m]	Cable connector <b>B</b> (Intended for robot or tool end)					
	WM1-A-10-01-01a	WM1-A-10-02-01a	WM1-A-11-02-01a	WM1-A-01-01-01a	WM1-A-01-02-01a	WM1-A-01-02-02a	Type	Pins	Gender	Rotation (deg.)	Code	Conn. angle (deg.)		Type	Pins	Gender	Rotation (deg.)	Code	Conn. angle (deg.)
WM1-A-14-01-01			A	B		B	M12	12	M	180	A	90	0,23	M8	8	M	0	A	90
WM1-A-14-01-02	A			B		B	M12	8	F	0	A	90	0,32	M8	8	M	0	A	90
WM1-A-14-01-03		A		(B)		(B)	M12	8	M	0	A	90	0,1	M8	8	M	0	A	0
WM1-A-14-01-04		A			(B)		M12	8	M	0	A	90	0,1	M8	8	F	0	A	0

(B) = Not recommended to use this cable end to connect to the WINGMAN™ module because this connector end is I-shaped (Conn. angle = 0 deg.) which takes up more space and risk of collision with the robot arm is greater.

(Cable length may vary up to 5-10%)

BLANK  
PAGE



### General information

The WINGMAN™ Air Modules are suitable for compressed air and vacuum applications.

The Air Modules have free passage of air without valves inside the modules.

INTERFACES AND PROPERTIES	
Number of air ports:	2 pcs.
Port threads / Intended for hose size:	M7 / Ø6mm
Pressure range:	-0,9 to 10 bar
<b>I-shaped</b> (included):	PN: WM1-A-15-01 (Ø6mm hose)
Suggested <b>L-shaped</b> push-in for 6 mm hose (not included):	FESTO: 153348 QSML-6H
O-ring seal between modules [mm]:	O-ring 5,00- 1,00 NBR 70
Housing material:	Surface treated aluminum (Color tone may vary)

### Warning

Energy (vacuum or air pressure) to the Air Module must be turned off and any residual air pressure or vacuum in the system must be eliminated before tool change takes place. Failing in doing so can result in hardware damage and injury.



# DATASHEET

## Pass-through - Air - Module - Ø6mm



Part number: WM1-A-03-...

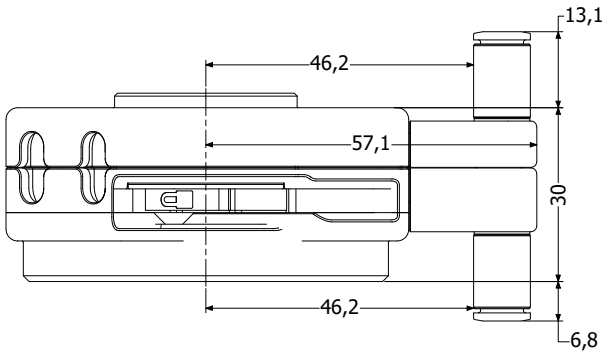

Modules for **robot** side (side A)

Modules for **tool** side (side B)



**WM1-A-03-01**

**WM1-A-03-02**

*2x6mm with I-shaped push-in for Robot Part*

*2x6mm with I-shaped push-in for Tool Part*



2 pcs. plugs (WM1-A-15-03) are included with module WM1-A-03-02 to allow this module to be used as a cap to close off the air lines from module WM1-A-03-01.



© All rights reserved TripleA robotics APS 2024. Reservations are made for errors, incorrect, missing or obsolete information





**WM1-A-06-01**



**WM1-A-06-02**



**WM1-A-06-03**

### General information

#### AIR FITTINGS FOR BUILT-IN AIR PORTS

Part number	Description	Threads	Hose size	Photo
WM1-A-06-01	2 pcs. Push-in fittings, I-shaped. (Festo 132917 - QSM-M5-4-I-R)	M5	OD 4mm	
WM1-A-06-02	2 pcs. Push-in fittings, L-shaped. (Festo 130771 - QSML-M5-4)	M5	OD 4mm	
WM1-A-06-03	2 pcs. Plugs. (Festo 578404- NPQH-BK-M5-P10)	M5	-	

Pass-through - Air - Fittings Ø4mm/M5 (two fittings installed on one "built-in" air port)

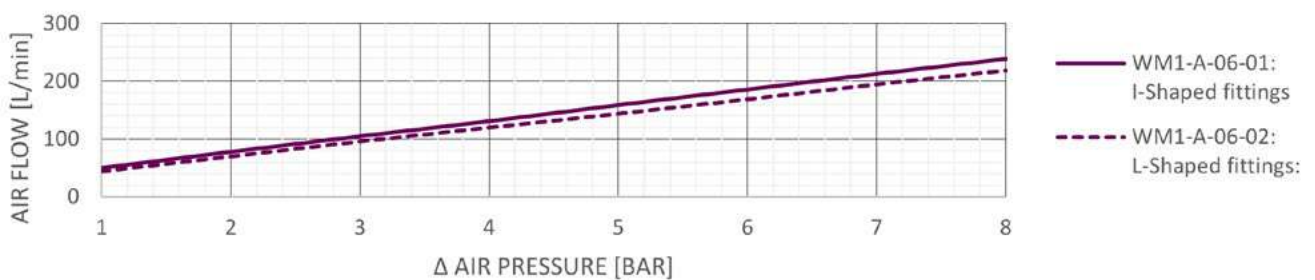

# DATASHEET

## Pass-through - Air - Fittings Ø6mm/M7



Part number: WM1-A-15-...



**WM1-A-15-01**



**WM1-A-15-03**

### General information

#### AIR FITTINGS FOR AIR MODULES

Part number	Description	Threads	Hose size	Photo
WM1-A-15-01	2 pcs. Push-in fittings, I-shaped. (Festo 132919 - QSM-M7-6-I-R)	M7	OD 6mm	
WM1-A-15-02	2 pcs. Push-in fittings, L-shaped. (Festo 130774 / QSML-M7-6)	M7	OD 6mm	
WM1-A-15-03	2 pcs. Plugs. (Festo 578405 - NPQH-BK-M7-P10)	M7	-	

Pass-through - Air - Fittings Ø6mm/M7 (two fittings installed on one "module" air port)

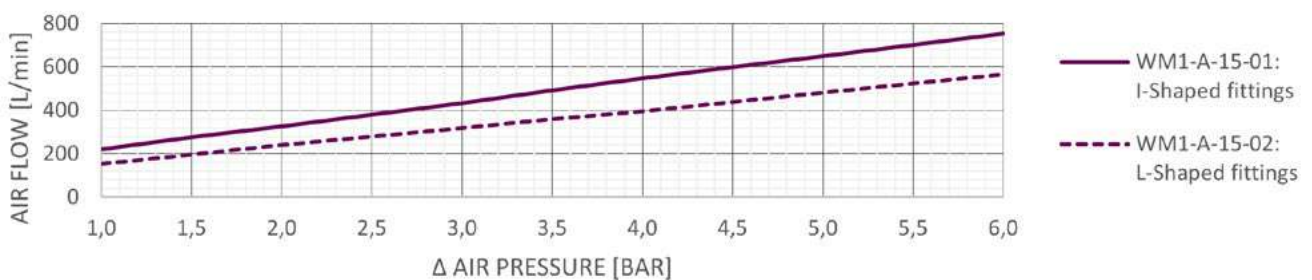

© All rights reserved TripleA robotics ApS 2024. Reservations are made for errors, incorrect, missing or obsolete information





**General information**

PROPERTIES	
Material	TPE-U(PU)
Temperature-dependent operating pressure	-0.95 bar ... 10 bar
Operating pressure complete temperature range	-0.95 bar ... 6 bar

**Hoses**

AIR HOSES			
Part number	Description	OD / ID	Length
WM1-A-18-04-05	Air hose, OD 4mm, ID 2,6mm (Festo 197383 - PUN-H-4X0,75-BL)	4mm / 2,6mm	5 m
WM1-A-18-06-05	Air hose, OD 6mm, ID 4,0mm (Festo 197384 - PUN-H-6X1-BL)	6mm / 4,0mm	5 m
WM1-A-18-08-05	Air hose, OD 8mm, ID 5,7mm (Festo 197385 - PUN-H-8X1,25-BL)	8mm / 5,7mm	5 m

**Hose splitters**

AIR HOSE Y-SPLITTERS				
Part number	Description	Hose size A	Hose size B	Photo
WM1-A-19-04-06	2 pcs. Push-in fitting, Y-splitter for hose. (Festo 153374 - QSMY-6-4)	2x OD 4mm	1x OD 6mm	
WM1-A-19-06-08	2 pcs. Push-in fitting, Y-splitter for hose. (Festo 153154 - QSY-8-6)	2x OD 6mm	1x OD 8mm	

© All rights reserved TripleA robotics APS 2024. Reservations are made for errors, incorrect, missing or obsolete information

BLANK  
PAGE

© All rights reserved TripleA robotics ApS 2024. Reservations are made for errors, incorrect, missing or obsolete information



**General information**

The Suction Modules are designed for vacuum/suction applications only (**NOT compressed air**) and for applications such as sucking away debris from a process..

PROPERTIES	
Ports:	1 pcs.
Internal port passage:	Ø22 mm
Pressure range:	-0,8 to 0 bar ( <b>vacuum only</b> )
Included O-ring seal between module and hose adaptor:	O-ring 25,00- 2,00 NBR 70
Housing material:	Surface treated aluminum (Color tone may vary)
IP classification when engaged:	Minimum IP54

**Hose adaptors**



To install a hose to the Suction Module, you will need to add a Hose Adaptor.

You can design your own Hose Adaptors and 3D print on your own 3D printer or you can acquire the standard Hose Adaptors from TripleA robotics. Hose Adaptors from TripleA robotics has part number WM1-A-16-... See page [E-26](#)

**Warning**



The Suction Modules are not for compressed air. Used with compressed air can result in hardware damage and injury.

Energy (vacuum) to the Suction Module must be turned off and any residual vacuum in the system must be eliminated before tool change takes place. Failing in doing so can result in hardware damage and injury.



# DATASHEET

## Pass-through - Suction - Module - Ø22mm



Part number: WM1-A-12-...

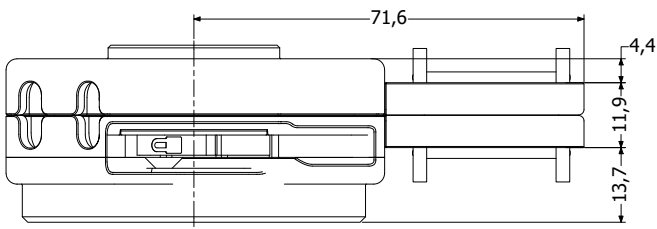

Modules for **robot** side (side A)



**WM1-A-12-01-01a**

22mm diameter suction module for Robot Part

Modules for **tool** side (side B)



**WM1-A-12-02-01a**

22mm diameter suction module for Tool Part



MATCH



**WM1-A-08-02-02a**

Cap module for suction module

MATCH



© All rights reserved TripleA robotics APS 2024. Reservations are made for errors, incorrect, missing or obsolete information

**WM1-A-16-00-02a**



**WM1-A-16-00-01a**



### General information

The Hose Adaptors are the interface between the WINGMAN Suction Modules part number WM1-A-12-... are a hose.

1. You can buy the standard Hose Adaptors from TripleA robotics part number WM1-A-16-... These will fit to hose with part number WM1-A-17-00-... Please see next page.
2. You can 3D print our standard Hose Adaptors yourself from STEP files provided by TripleA robotics (provided without liability for and without support from TripleA robotics).
3. You can design and 3D print your own Hose Adaptors to fit your application and the hose you would like to deploy.

PROPERTIES	
Material:	3D printed
Operation temperature:	5 to 40 degrees celsius
Pressure range:	-0,8 to 0 bar ( <b>vacuum only</b> )

The standard Hose Adaptors WM1-A-16-... from TripleA robotics are suitable for most tools and for most cobots with a robot head diameter of maximum 90mm.

### Warning

The Hose Adaptors are not for compressed air. Usage with compressed air can result in hardware damage and injury.

Energy (vacuum) to the Suction Module must be turned off and any residual vacuum in the system must be eliminated before tool change takes place. Failing in doing so can result in hardware damage and injury.



# DATASHEET

## Pass-through - Suction - Module - Ø22mm hose adaptor



Part number: WM1-A-16-..., WM1-A-17-...

### WM1-A-16-00-01a

Suggested Hose Adaptor for robot side

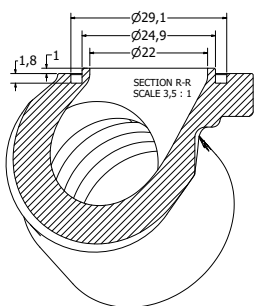
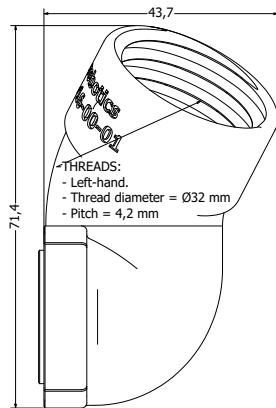
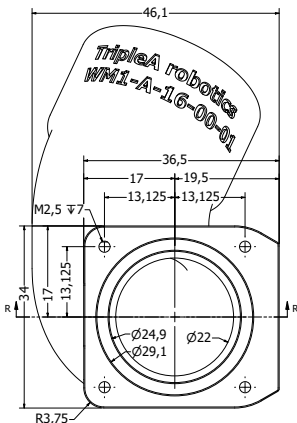
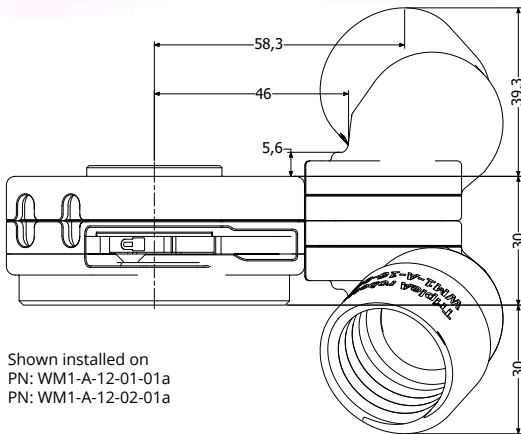

### WM1-A-16-00-02a

Suggested Hose Adaptor for tool side

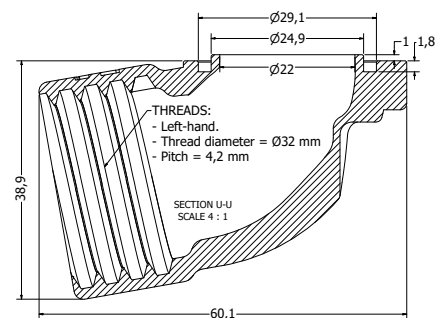
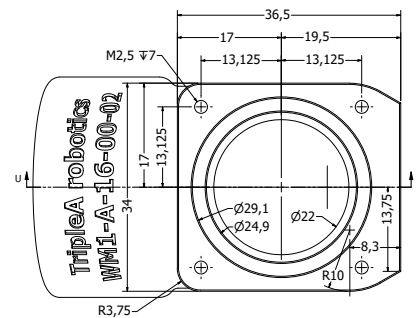
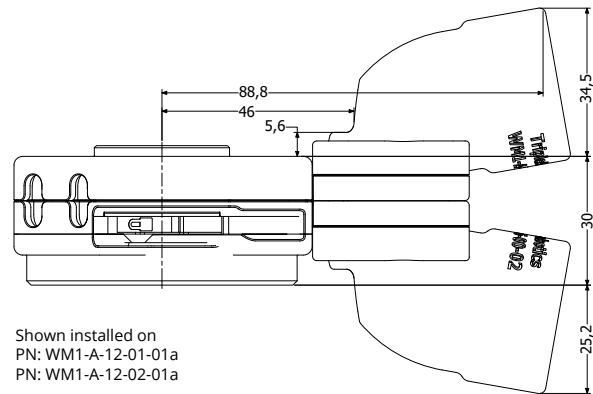

### WM1-A-17-00-05

Hose, spiral ID 25mm, Type 1, 5m



5 meter spiral hose for suction applications. Fits to all Hose Adaptors starting with WM1-A-16-00-...

#### WARNING!

For suction applications only.



© All rights reserved TripleA robotics ApS 2024. Reservations are made for errors, incorrect, missing or obsolete information



**General information**

Oasionally you might want to do automatic tool change between e.g. an electrical tool and one that is not. This is when you want to install a **Cap Module** on the tool side (side B) of the non-electrical tool in order to protect the electrical module installed on the robot side (side A).

The **Cap Modules** are designed in such a way that the original gaskets of the opposite module in the robot side (side A) will seal to the **Cap Module** keeping the IP rating of the module, installed on the robot side (side A), intact.

PROPERTIES	
Material:	Surface treated aluminum (Color tone may vary)
IP classification when engaged with matching pass-through module:	Minimum IP54

INTERFACES CAP MODULE SIZE 1	
Pass-through module installed on robot side (side A)	Cap module installed on tool side (side B)
WM1-A-01-01-01	<b>WM1-A-08-02-01</b>

INTERFACES CAP MODULE SIZE 2	
Pass-through module installed on robot side (side A)	Cap module installed on tool side (side B)
WM1-A-09-01-01a	<b>WM1-A-08-02-02a</b>
WM1-A-10-01-01a	
WM1-A-11-01-01a	
WM1-A-12-01-01a	

© All rights reserved TripleA robotics ApS 2024. Reservations are made for errors, incorrect, missing or obsolete information

**WM1-A-08-02-01**

Cap module **SIZE 1** for Tool Part



Cap module  
**WM1-A-08-02-01**

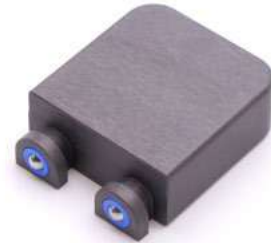

To protect module:  
WM1-A-01-01-01

**WM1-A-08-02-02a**

Cap module **SIZE 2** for Tool Part



Cap module  
**WM1-A-08-02-02a**



To protect module:  
WM1-A-09-01-01a  
WM1-A-10-01-01a  
WM1-A-11-01-01a

To protect module:  
WM1-A-12-01-01a

© All rights reserved TripleA robotics ApS 2024. Reservations are made for errors, incorrect, missing or obsolete information



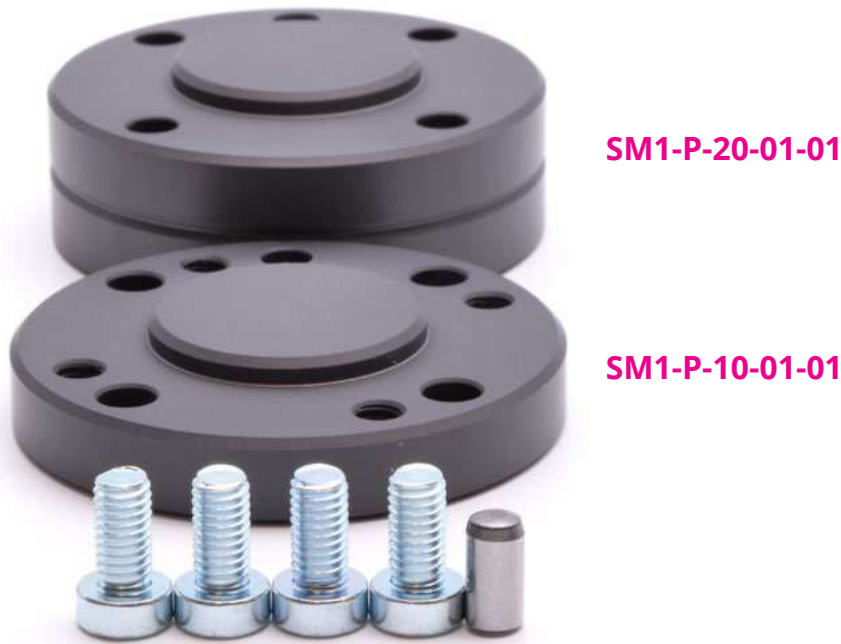

**General information**

The SPACEMAN™ Spacer Type 1 has the standard cobot ISO 9409-1-50-4-M6 flange on both sides.

PROPERTIES	
Material:	Surface treated aluminum (Color tone may vary)
Screws and dowel pin for Robot Part, included:	4 pcs. M6x12mm (ISO14580) 1 pcs. Ø6h6x12mm (ISO 6325)

INTERFACES	
SPACEMAN™ Adaptor, Type 1	Flange side 1: ISO 9409-1-50-4-M6 (male) Flange side 2: ISO 9409-1-50-4-M6 (female)

**Fits on both sides of the WINGMAN™**

The SPACEMAN™ can be installed on both sides of the WINGMAN™ Cobot Tool Changer Interfacing with the WINGMAN Robot Part WM1-P-01-01-... and the WINGMAN Tool Part M1-P-02-01-....



**Stackable**

The SPACEMAN™ can be stacked to create even more space. Each time you add a spacer, the tool flange will rotate 22,5 degrees.



© All rights reserved TripleA robotics ApS 2024. Reservations are made for errors, incorrect, missing or obsolete information

**SM1-P-10-01-01**

SPACEMAN™ Spacer Type 1, 10mm

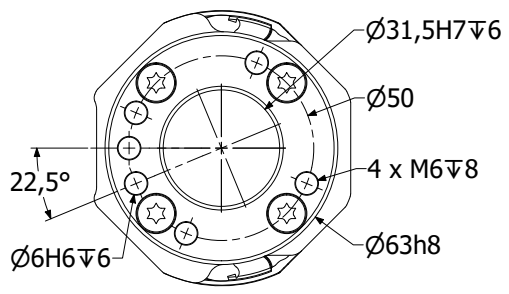
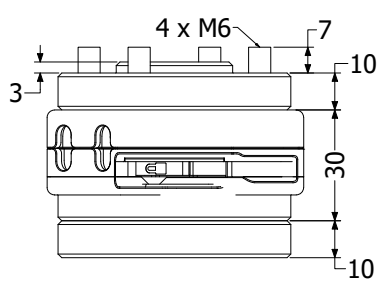
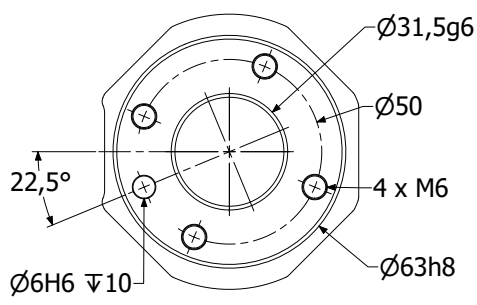

**SM1-P-20-01-01**

SPACEMAN™ Spacer Type 1, 20mm

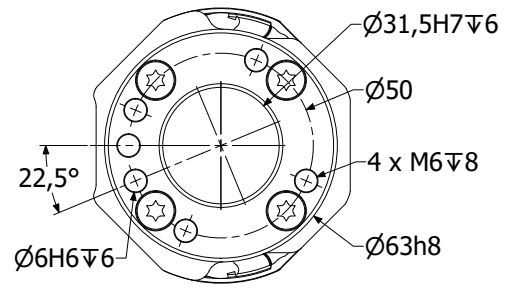
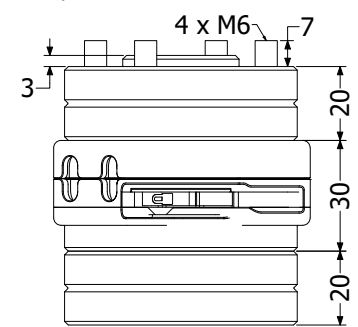
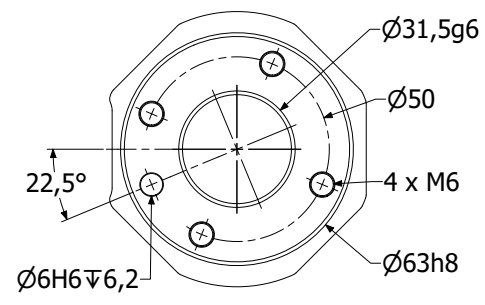

© All rights reserved TripleA robotics APS 2024. Reservations are made for errors, incorrect, missing or obsolete information

BLANK  
PAGE

# F- SPARE PARTS

## CONTENTS

Spare parts - WINGMAN Robot Part - WM1-P-01-01-...	<b>F-2</b>
Spare parts - WINGMAN Tool Part - WM1-P-02-01-...	<b>F-3</b>



**WM1-P-01-01...**  
The WINGMAN Robot Part  
**E-2**

### Spare parts

A	
Desc:	Plug screw set, M5
Qty:	2 pcs.
PN:	WM1-A-06-03

1	
Desc:	Screw M6x12mm
Qty:	5 pcs.
See kit: WM1-SK-01-00	

2	
Desc:	Pin Ø6h6x10mm
Qty:	1 pcs.
See kit: WM1-SK-01-00	

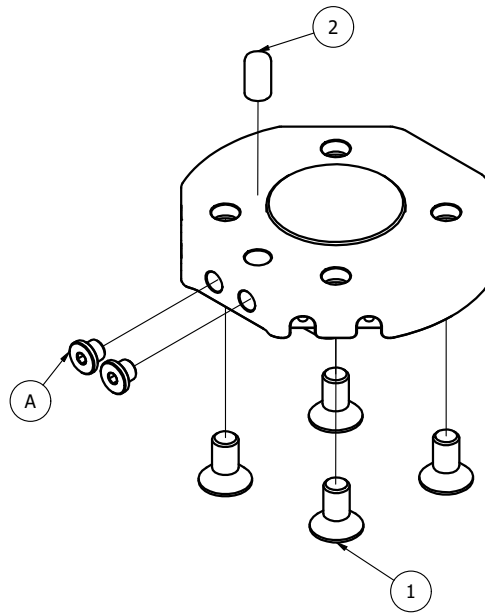

### Spare part kits

WM1-SK-01-00	
Desc:	Screw and pin kit
Included:	1, 2



# Spare parts

## Spare parts - WINGMAN Tool Part - WM1-P-02-01-...



Part number: SM1-P-02-01-...



**WM1-P-02-01...**  
The WINGMAN Tool Part  
**E-2**

### Spare parts

A	
Desc:	Plug screw set, M5
Qty:	2 pcs.
PN:	WM1-A-06-03

1	
Desc:	Screw set
Qty:	4 pcs.
PN:	WM1-S-02-01

2	
Desc:	Slide set
Qty:	2 pcs.
PN:	WM1-S-02-02

3	
Desc:	Springs, long
Qty:	2 pcs.
PN:	WM1-S-02-03

4	
Desc:	Springs, short
Qty:	2 pcs.
PN:	WM1-S-02-04

5	
Desc:	Lock pads
Qty:	2 pcs.
See kit: WM1-SK-01-02	

6	
Desc:	Pin set
Qty:	4 pcs.
PN:	WM1-S-02-06

7	
Desc:	Bearing set
Qty:	4 pcs.
PN:	WM1-S-02-07

8	
Desc:	Spring supprt
Qty:	2 pcs.
PN:	WM1-S-02-08

9	
Desc:	Levers
Qty:	2 pcs.
See kit: WM1-SK-01-03	

10	
Desc:	O-ring set
Qty:	5 pcs.
PN:	WM1-S-02-10

11	
Desc:	Housing, middle
Qty:	1 pcs.
PN:	WM1-S-02-11

12	
Desc:	Housing, bottom
Qty:	1 pcs.
PN:	WM1-S-02-12

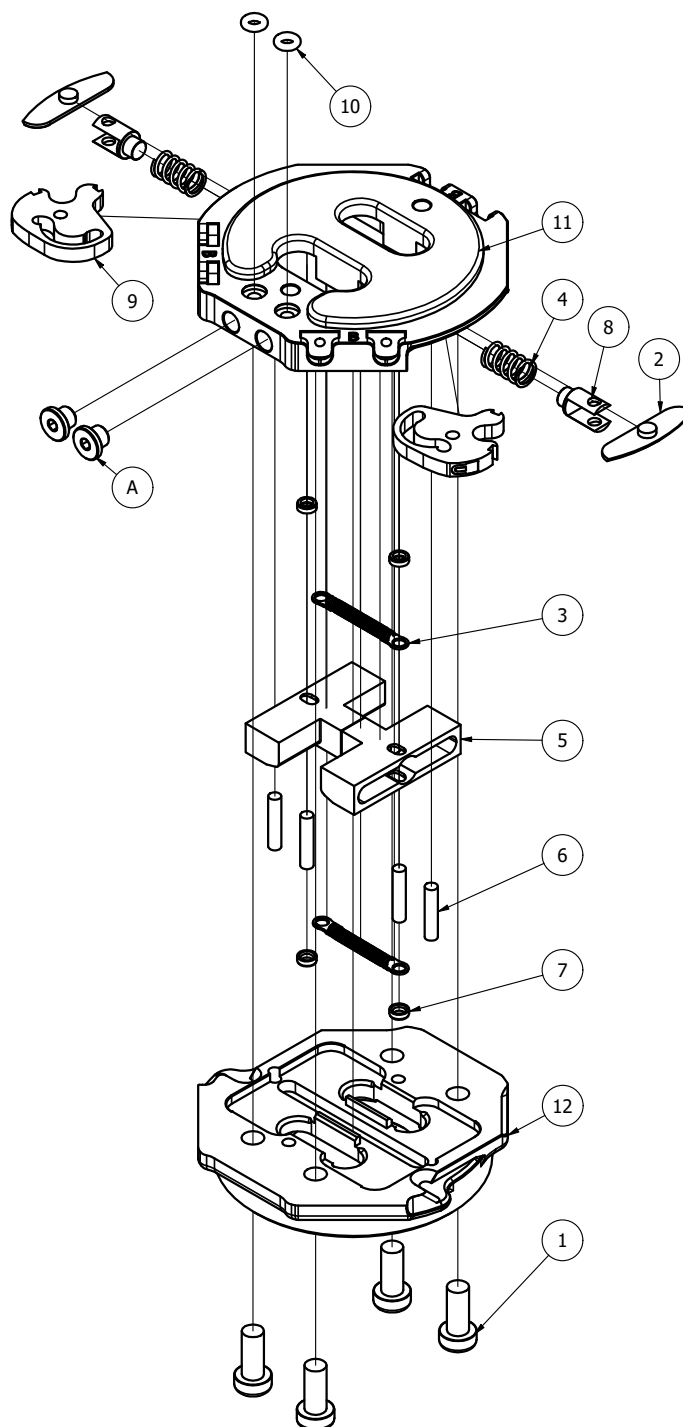

### Spare part kits

WM1-SK-01-01	
Desc:	Wear rep. kit
Included:	2, 3, 6, 7, 8, 9

WM1-SK-01-02	
Desc:	Lock pad rep. kit
Included:	4, 5, 6, 8, 10

WM1-SK-01-03	
Desc:	Lever rep. kit
Included:	6, 7, 8, 9

© All rights reserved TripleA robotics ApS 2024. Reservations are made for errors, incorrect, missing or obsolete information



## APPLICABLE

No nonsens products

## AFFORDABLE

Best value for money

## ADAPTABLE

LEGO like customiization

 **WINGMAN**  
THE COBOT TOOL CHANGER SYSTEM

### OUR MISSION

It's our mission to earn your trust and recognition as the world's best provider for automatic tool change for cobots